

CHANGE DATE	CHANGE DESCRIPTION	CHANGE NO.	NAME	 RESTRICTED USAGE , PLEASE DON'T FORWARD TO ANYONE WHO ISNT AUTHORIZED	DRAWN BY	UNITS	MM	SALES BLOW UP DIAGRAM	DIAGRAM NO.	GLW-F101B-A	
					VERIFIED BY	QTY	1				N952
						VERSION	A0	XX		MODEL	
						RATIO	1:16				

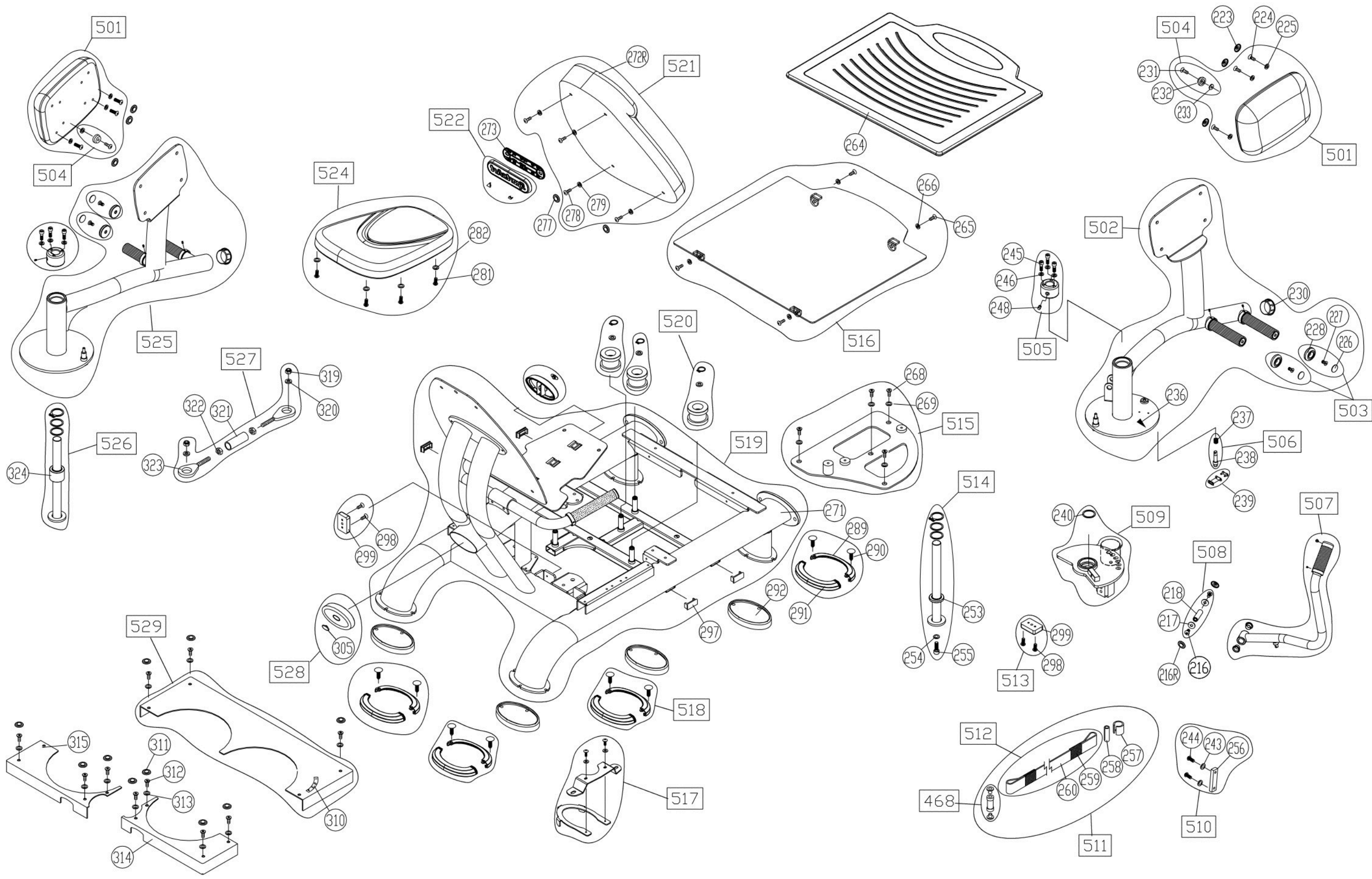

CHANGE DATE	CHANGE DESCRIPTION	CHANGE NO.	NAME	SportsArt FITNESS		UNITS	MM	SALES BLOW UP DIAGRAM	DIAGRAM NO.	GLW-F101C-A
						QTY	1			N952
						VERSION	A0	XX	MODEL	
						RATIO	1:11			

RESTRICTED USAGE ,
PLEASE DON'T FORWARD TO ANYONE WHO ISNT AUTHORIZED

DRAWN BY
VERIFIED BY