

A965 OWNER'S MANUAL CONTENTS

1. INTRODUCTION	2
2. SAFETY PRECAUTIONS	3
3. LIST OF PARTS	4
4. ASSEMBLE THE PRODUCT	6
STEP 1 Install Frames and Weight Plate Pegs	6
STEP 2 Secure the Unit	8
STEP 3 Level the Unit	9
STEP 4 Unit Inspection	10
5. OPERATE THE PRODUCT	11
OPERATION Exercising Instructions	11
6. MAINTENANCE	13
MAINTENANCE Safety Precautions	13
MAINTENANCE Schedule	14
MAINTENANCE Task List	15
MAINTENANCE One-Year Maintenance Log	16
7. CONSIGNES DE SÉCURITÉ IMPORTANTES	17
8. APPENDIXES	18
APPENDIXES Exploded Diagram	18

*We reserve the right to revise this manual at any time without notice.

1. INTRODUCTION

Congratulations on the purchase of a high quality SportsArt product, the A965 Squat Rack. Constructed of high quality materials and designed for years of reliable performance, this product was made for full commercial use.

Before this product is assembled or operated, we recommend that you familiarize yourself with this manual. Understanding the correct assembly and operation of this product will help ensure that exercisers obtain their fitness goals safely and successfully.

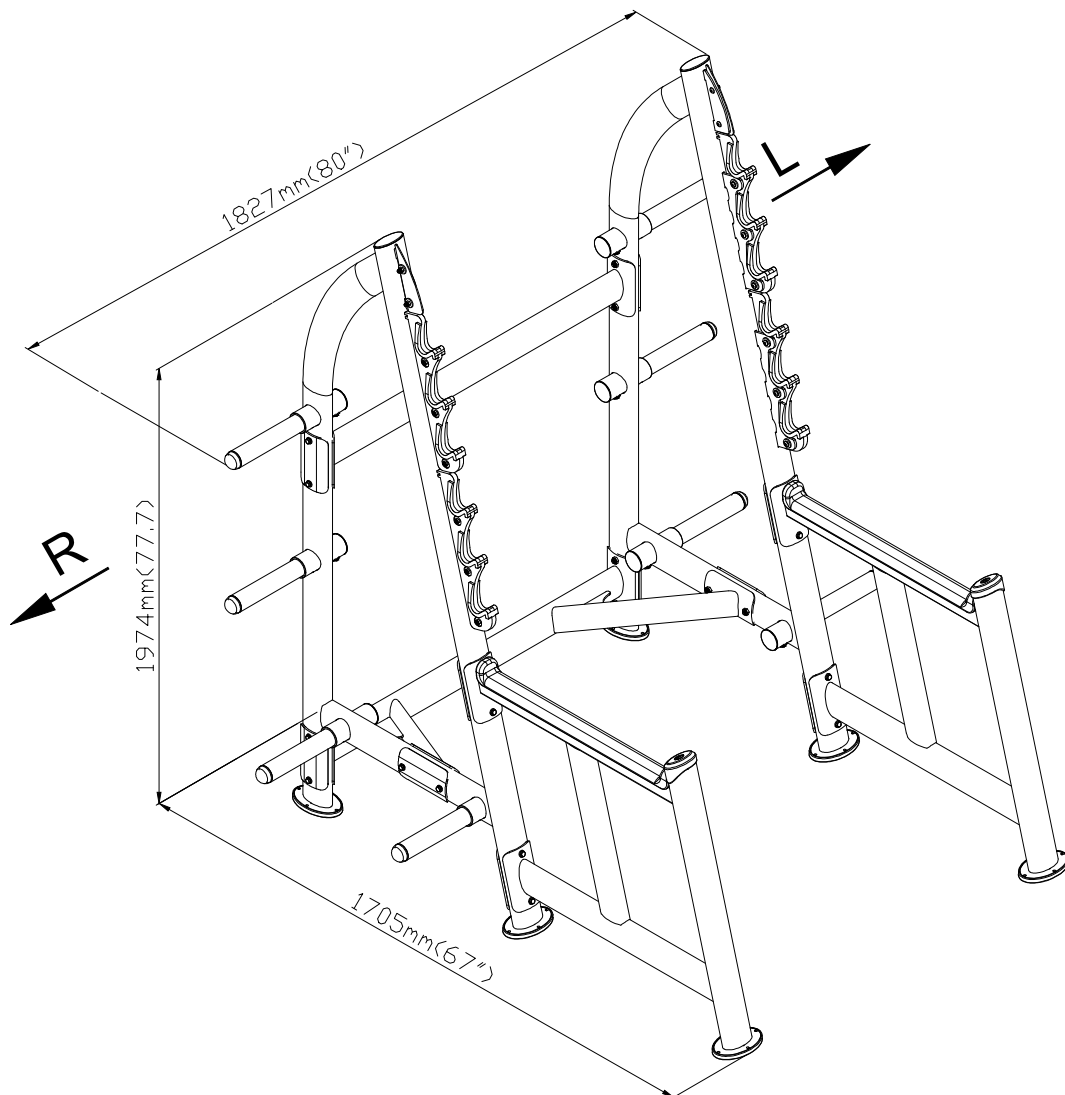

2. SAFETY PRECAUTIONS

This product was designed and built for optimum safety. However certain precautions apply during the use of this product. Please note the following safety precautions:

- Please read the entire manual before assembly and operation. Make sure the product is installed and operated as instructed in this manual.
- Assemble and operate the product on a solid, level surface. Do not use outdoors or near water, including pools and saunas.
- Check the product before every use. Make sure all parts are assembled, and all fasteners are tightened. Do not use the product if it is disassembled in any way.
- Wear proper workout clothing. Do not wear loose clothing. Do not wear shoes with leather soles or high heels. Tie all long hair back. Do not go barefoot on this product.
- Keep away from moving parts. Moving parts may or may not stop immediately if an object becomes caught or impedes normal motion.
- Use this product only for its intended purpose as described in this manual.
- Be careful when mounting and dismounting the unit.
- Never operate this product if it has been damaged in any way. If it is not working properly, or has been dropped or damaged, contact a service technician for repairs.
- Do not use accessories or parts that are not specifically recommended by the manufacturer (SportsArt) . Such parts might cause injuries or cause the unit to fail and void the warranty. We will not be responsible for any safety issue that arises due to the misuse of accessories or parts. At the same time, we will terminate the warranty terms of this equipment.
- This product is not intended for use by persons (including children 12 or younger) with reduced physical, sensory, or mental capabilities, or by people who are otherwise deficient in product knowledge or experience. If such people use this product, they should be given training and be supervised at all times by someone responsible for their safety.
- Children 12 or younger should be supervised to ensure that they do not play on or near the product.
- The user weight limit for this product is 227 kg, 500 lb.
- Contact your SportsArt representatives on all materials damaged in shipment. (Note: Shipping damages are the responsibility of the carrier.)
- Unpack and verify contents of boxes according to the list of parts to check if any parts are missing.
- Maintenance and repair must be performed by trained service personnel only. Improper maintenance would not only damage the machine, but also may present a danger to the exerciser.
- Warning that any of the adjustment devices that could interfere with the user's movement should not be left projecting.
- Over exercise may result in serious injury or death.

CAUTION: If you feel any pain or any abnormal sensations, STOP YOUR WORK-OUT and consult your physician immediately. Work within your recommended exercise level. DO NOT work to exhaustion. Before beginning any exercise program, you should consult with your doctor. It is recommended that you undergo a complete physical examination.

3. LIST OF PARTS

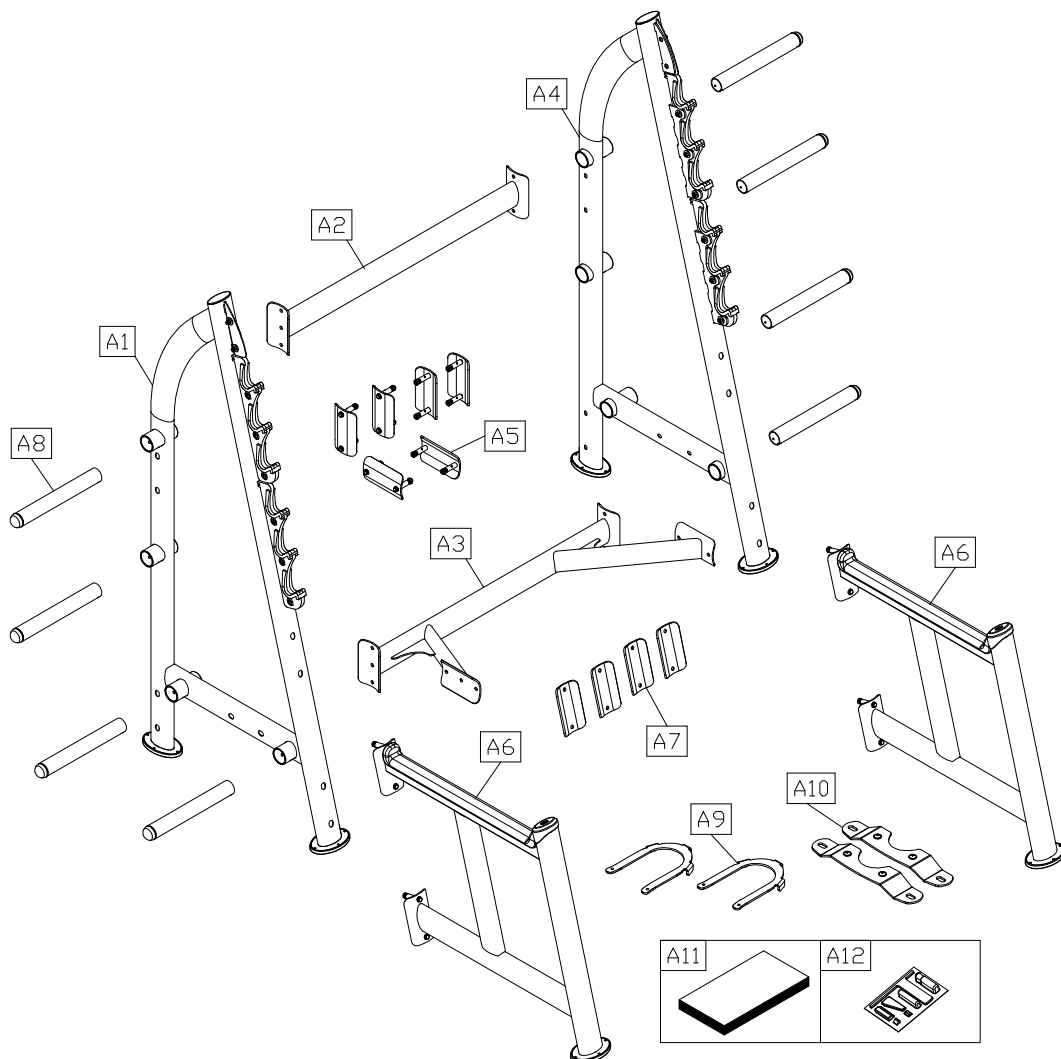

Assembly Parts					
No.	Name	Qty.	No.	Name	Qty.
A1	Right frame	1	A7	Connecting plate B	4
A2	Connector B	1	A8	Weight plate peg	8
A3	Connector A	1	A9	Floor fixing bracket	2
A4	Left frame	1	A10	U Clip	2
A5	Connecting plate A	6	A11	Owner's manual	1
A6	Support frame	2	A12	Hardware kit	1

Components in the Hardware Kit				
No.	Name	Qty.	Specification	Notes
	Double open-end wrench	2	13mm*17mm	
	L-shaped Allen wrench	1	M5*L65mm	
	L-shaped Allen wrench	1	M4*L60mm	
	Screwdriver shank	1	Flat and Phillips	

Components on the Product			
No.	Name	Specification	Notes
31	Washer	D16*d10.2*t1.0	
	Hex nylon nut	M10	
32	Inner hex screw	M6*L10	
	Spring washer	M6	
	Handrail washer	D20*d7*t2.0	
33	Mushroom top Phillips screw	M5*P0.8*L15	
	Flat washer	D13*d5.2*t1.0	
34	Mushroom inner hex screw	M6*P1.0*L15	
	Spring washer	M6	
	Handrail washer	D20*d7*t2.0	

4. ASSEMBLE THE PRODUCT

Follow instructions below to assemble this product. Note that in this manual the words “left” and “right” are used to refer to the product and its parts. As such, these designations correspond to the “left” and “right” sides of a person in position to exercise on this product. Also, for brevity, the word “screws” is used where screws, washers, and other hardware may be involved.

STEP 1 Install Frames and Weight Plate Pegs

- (a) First, remove nuts from the connecting plate A (A5). Align the connector A (A3) and the connector B (A2) with the holes in the right frame (A1) and the left frame (A4) and then insert the connecting plate A (A5) onto the frames and loosely secure them in place with nuts as shown. Do not tighten nuts yet.

(Note: The frames are marked “L” for left or “R” for right as shown.)

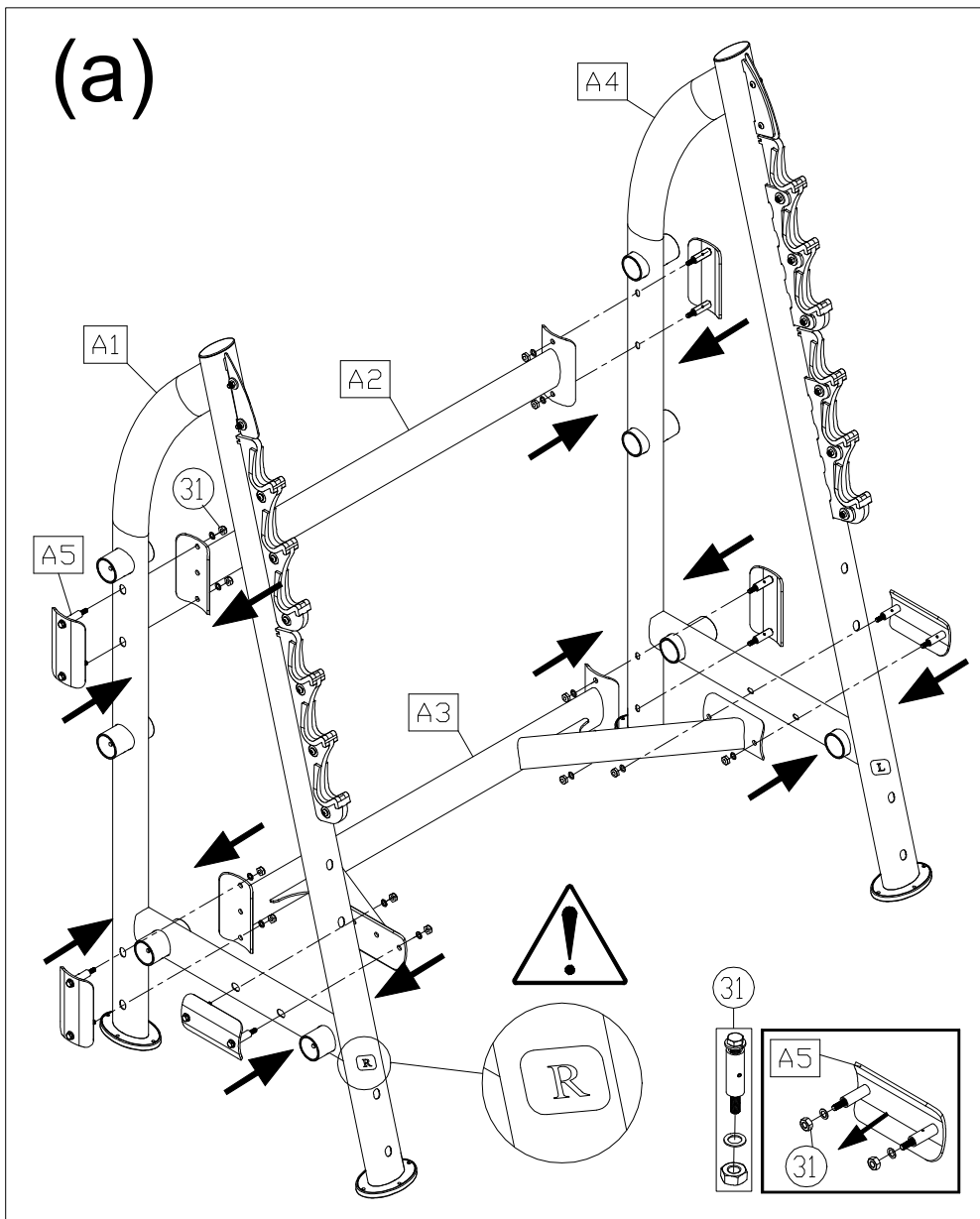

STEP 1 Install Frames and Weight Plate Pegs (Continued)

Note: Before assembling the support frame, set the unit on level floor.

- (b) First, remove nuts (31) from the support frame (A6). Align the support frame (A6) with the holes in the right frame (A1) and the left frame (A4) and then insert the connecting plate A (A5) onto the frames and loosely secure them in place with nuts (31) as shown. Do not tighten nuts yet.
(Note: Tighten all nuts once the whole assembly is completed.)
- (c) First remove screws (32) from the weight plate pegs (A8) and then loosen screws (34) from the left frame (A1). Install weight plate pegs (A8) onto the left frame (A1). Use screws (32) to secure the weight plate pegs.
(Note: Carry out the same procedure on the right frame (A4) as well.)

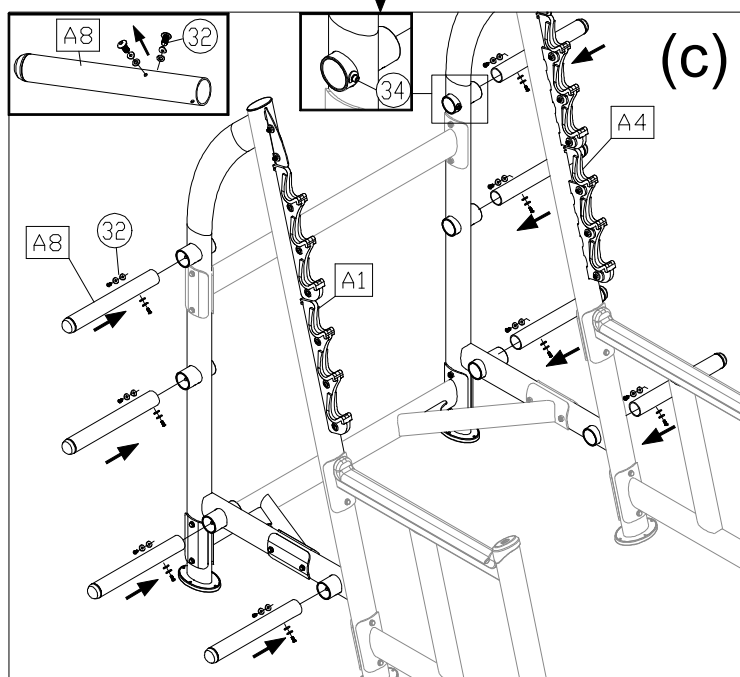
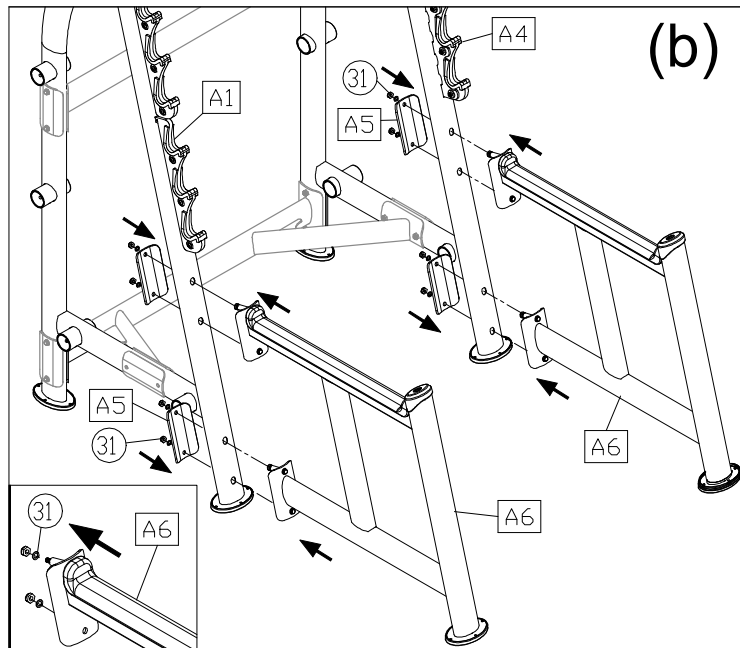

STEP 2 Secure the Unit

Please follow the instructions (a) through (c) to secure the unit to make sure the machine is firmly fixed to the floor when operating.

- (a) Remove screws (33) from the floor fixing bracket (A9).
- (b) Insert the U clip (A10) onto the machine (Make sure the U clip with the correct side downward as below shown), and then secure the floor fixing bracket (A9) with screws.
- (c) Secure the floor fixing bracket to the floor with the floor fixing bolt, nut and washer as shown

(Note: The screw hole of floor fixing bracket is $\varnothing 9\text{mm}$, please make sure using the suitable floor fixing bolt and drilling the proper hole on the floor.)

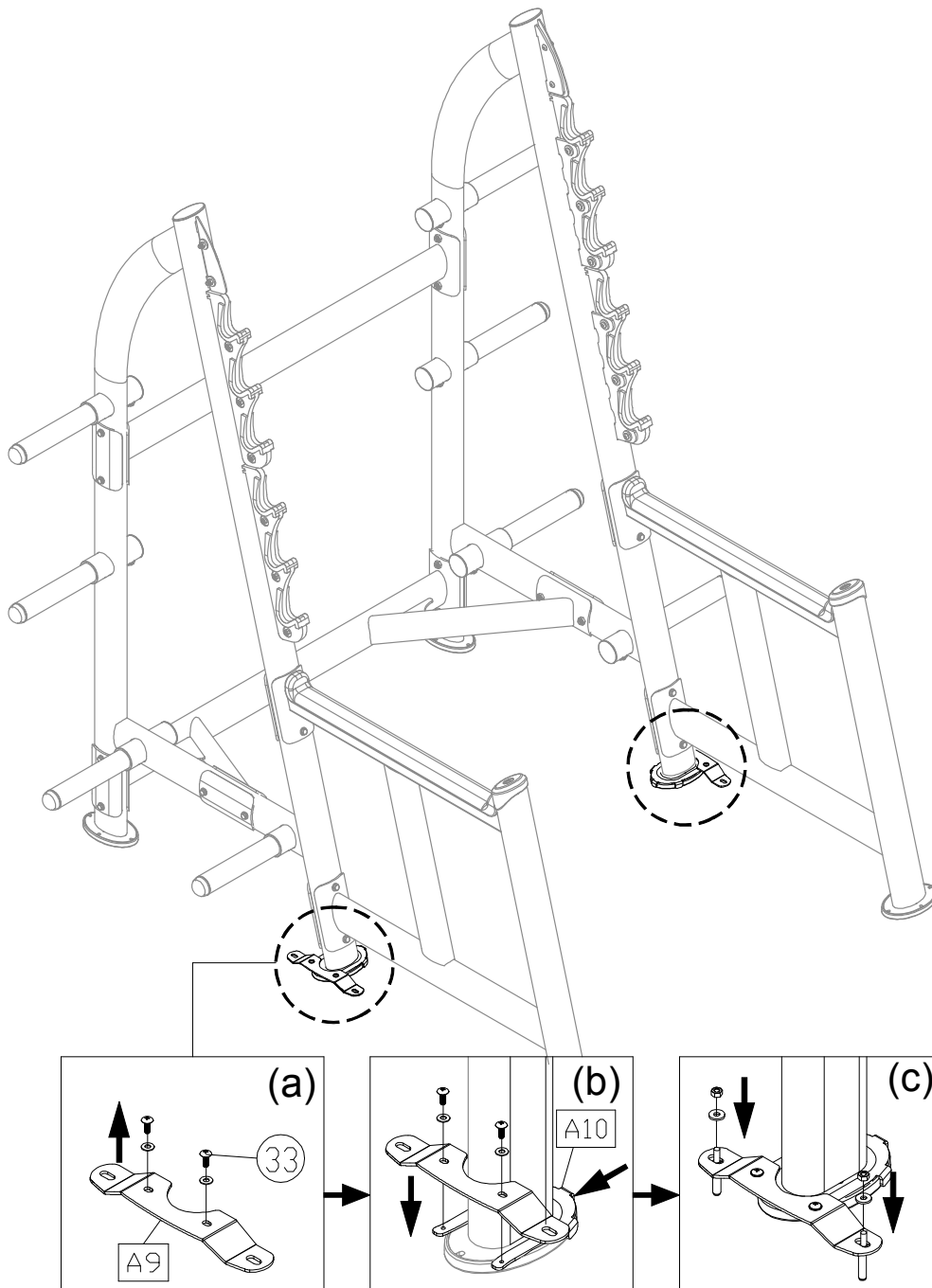

STEP 3 Level the Product

If the product is installed on an uneven surface to cause the instability of the product, place the support spacer under the foot pad to make sure its stability.

(A few support spacers are provided in the packaging of this product.)

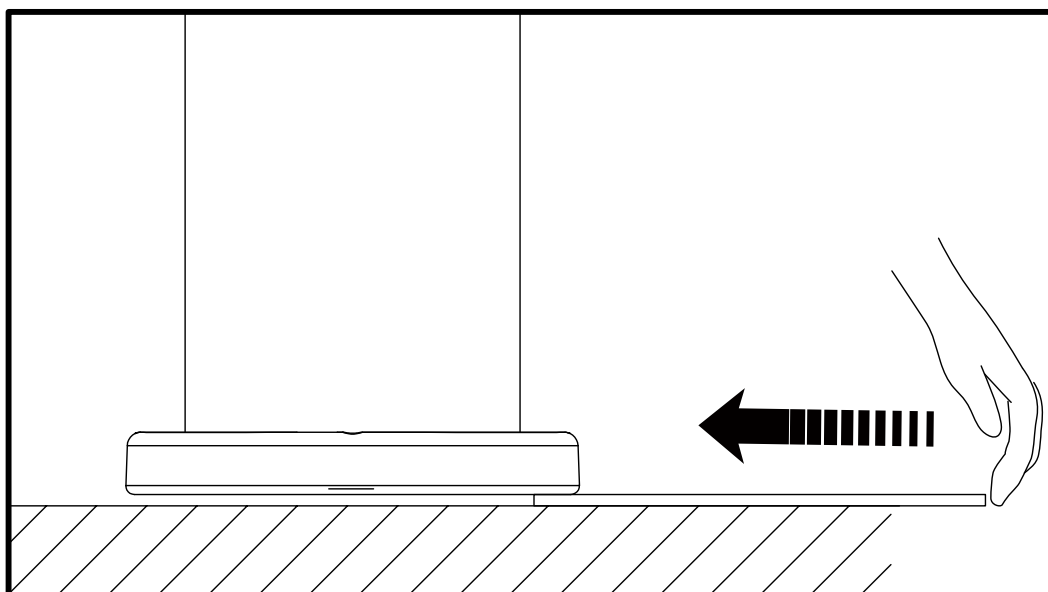

STEP 4 Unit Inspection

After completing the assembly or regular maintenance, please follow instructions (a) through (c) below to inspect the unit. If the unit is disassembled or has been damaged in any way, it might cause injuries or cause the unit to fail.

- (a) Make sure the unit is steady and on a level surface. If the unit is not steady, make adjustments according to the instructions “Level the Unit” of this manual.
- (b) Make sure all parts are assembled and all fasteners are tightened.
- (c) Please follow operating instructions to test operation and confirm that the equipment is working properly. (Please refer to “Operate the Product” of this manual.)

5. OPERATE THE PRODUCT

This section includes operational instructions.

OPERATION Exercising Instructions

- * Note: While operating the machine, if the weight plate is moving around. Please stop immediately, re-position the weight plate before continuing. Secure the weight plates with set springs. Partial insertion may cause the weight lifting bar to fall unexpectedly
- * Weight limit: Weight plate limit of 250Kg (Unilateral 125Kg)
- * Please exercise within the range of your skill and training. If you feel any pain or any abnormal sensations, STOP YOUR WORKOUT and consult your physician immediately
- * Operate this machine must be supervised under coaches instructions in order for safety.
- * If you feel faint, pain or any abnormal sensations during exercise, put the weight lifting rod on the support frame (A6).

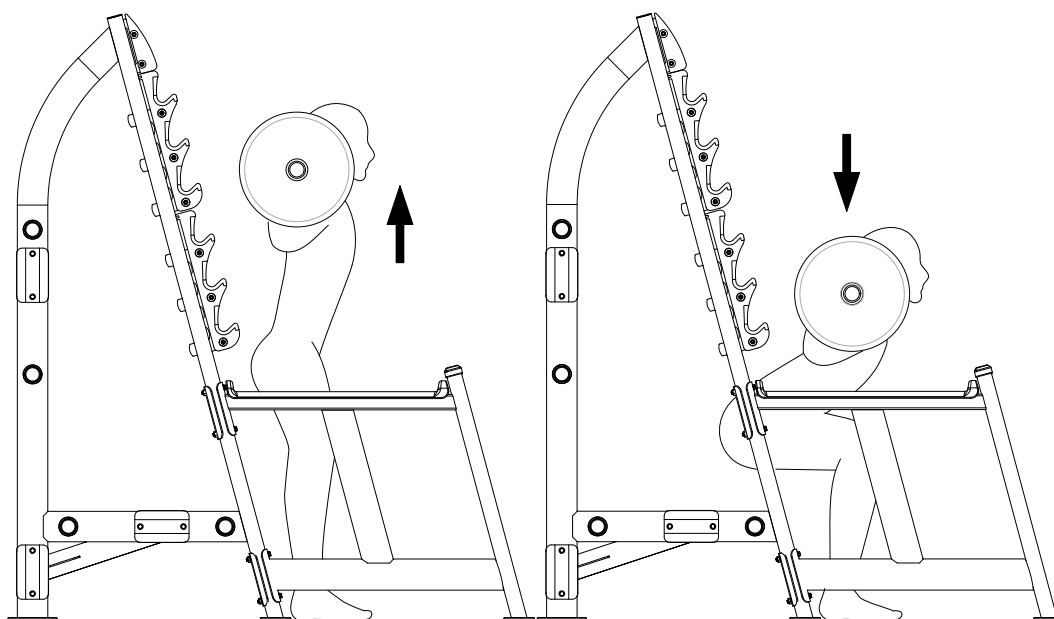

Fig 1. Exercise legs (*Please follow coaches' instructions.)

OPERATION Exercising Instructions (Continued)

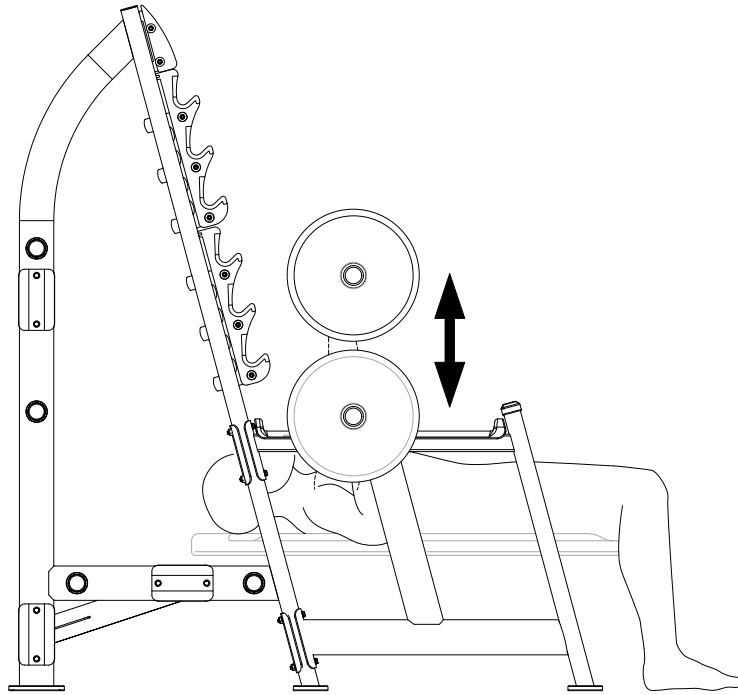

Fig 2. Using the bench with Squat Rack to exercise chest. (*Please follow coaches' instructions.)

6. MAINTENANCE

This section covers maintenance topics and includes a maintenance schedule, task list, and log.

MAINTENANCE Safety Precautions

- Please follow standard safety precautions when servicing on this product.
- Do NOT use a damp towel to clean the product and do perform the following maintenances.
- Do NOT use cleaners with alcohol, ammonia, or other damaging chemicals. The use of such chemicals can damage the product and void the warranty. Never spray or pour any liquid directly onto the product. Doing so can damage electronic components and void the warranty.
- Use a clean, lint-free towel, dampened with a mixture of Simple Green® all-purpose cleaner, to thoroughly clean the handlebar and the console.
- This product has moving parts that can be hazardous. Exercise caution when maintaining, operating, or moving this product.
- Do not use accessories or parts that are not specifically recommended by the manufacturer (SportsArt) . Such parts might cause injuries or cause the unit to fail and void the warranty. We will not be responsible for any safety issue that arises due to the misuse of accessories or parts. At the same time, we will terminate the warranty terms of this equipment.
- Maintenance and repair must be performed by trained service personnel only. Improper maintenance would not only damage the machine, but also may present a danger to the exerciser.
- Keep this product out of use until maintenance is completed.

MAINTENANCE Schedule

	Area	Day	Week	Month	Quarter	Year	Notes
1	Exterior	•					Clean.
2	Screws	•					Inspect for looseness and secure if necessary.

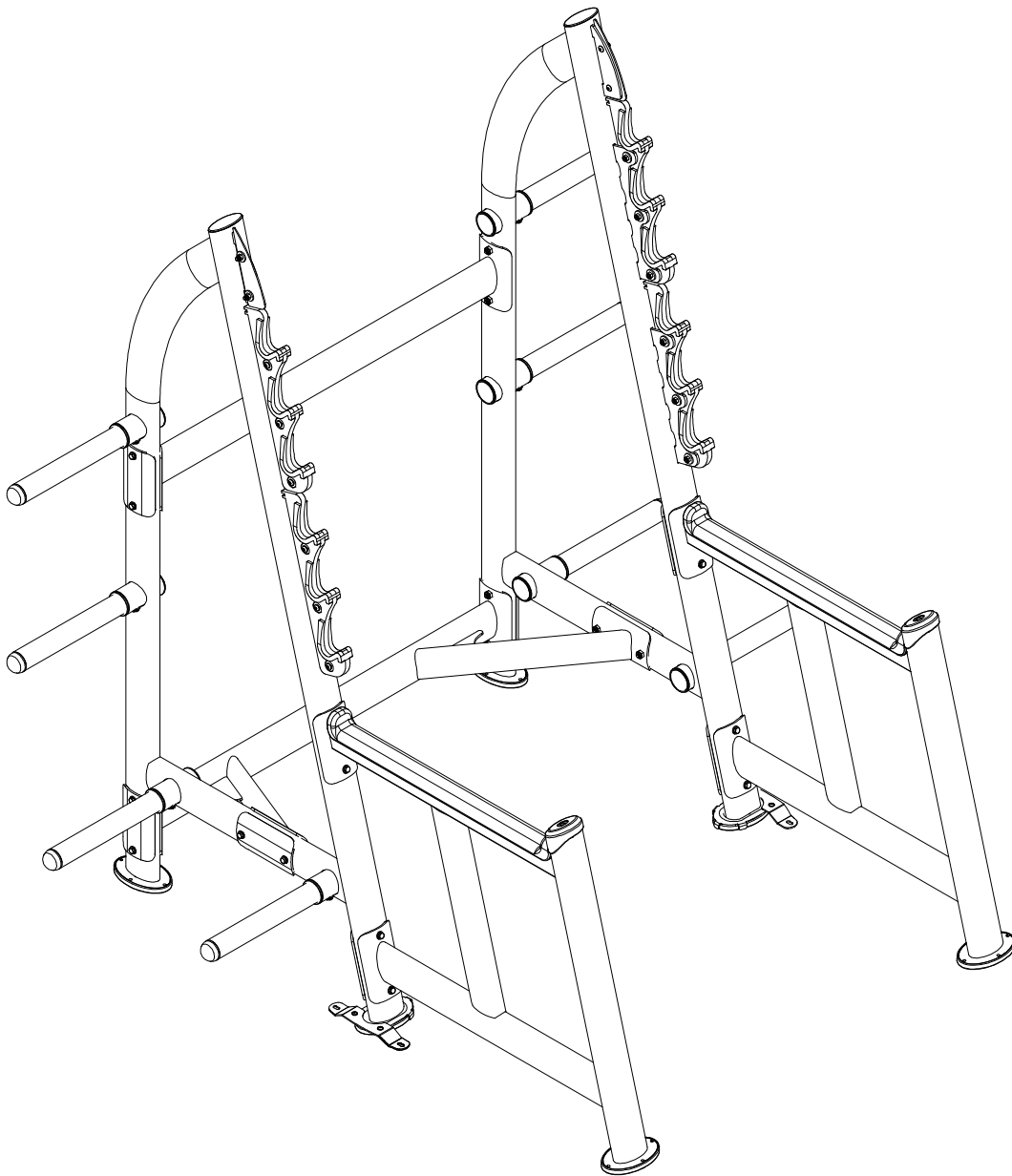

MAINTENANCE Task List

Like cars, fitness products require maintenance. Regular maintenance extends product life, and failure to maintain products can void the manufacturer's warranty. Copy the maintenance log sheet, and record maintenance work for each fitness product.

Daily tasks

1. Use a clean, lint-free towel to wipe down the product exterior.
2. Inspect all screws. Secure if necessary.

Caution

- Please follow standard safety precautions when working on this product.
- Do NOT use cleaners with alcohol, ammonia, or other damaging chemicals. The use of such chemicals can damage the product and void the warranty. Never spray or pour any liquid directly onto the product. Doing so can damage components and void the warranty.

MAINTENANCE One-Year Maintenance Log

Facility: _____ Supervisor: _____

Product model number: _____ Serial number: _____

Start date: _____ End date: _____

Daily Tasks	Weeks 1-7	Weeks 8-14	Weeks 15-21	Week 22-28
Completed	<input type="checkbox"/>	<input type="checkbox"/>	<input type="checkbox"/>	<input type="checkbox"/>

Daily Tasks	Week 29-35	Week 36-42	Week 43-49	Week 50-52
Completed	<input type="checkbox"/>	<input type="checkbox"/>	<input type="checkbox"/>	<input type="checkbox"/>

Weekly Tasks	Weeks 1-7	Weeks 8-14	Weeks 15-21	Weeks 22-28
Completed	<input type="checkbox"/>	<input type="checkbox"/>	<input type="checkbox"/>	<input type="checkbox"/>

Weekly Tasks	Weeks 29-35	Weeks 35-42	Weeks 43-49	Weeks 50-52
Completed	<input type="checkbox"/>	<input type="checkbox"/>	<input type="checkbox"/>	<input type="checkbox"/>

Monthly tasks	1	2	3	4	5	6	7	8	9	10	11	12
Completed	<input type="checkbox"/>	<input type="checkbox"/>	<input type="checkbox"/>	<input type="checkbox"/>	<input type="checkbox"/>	<input type="checkbox"/>	<input type="checkbox"/>	<input type="checkbox"/>	<input type="checkbox"/>	<input type="checkbox"/>	<input type="checkbox"/>	<input type="checkbox"/>

Quarterly Tasks	Quarter 1	Quarter 2	Quarter 3	Quarter 4
Completed	<input type="checkbox"/>	<input type="checkbox"/>	<input type="checkbox"/>	<input type="checkbox"/>

Yearly Tasks	Year 1
Completed	<input type="checkbox"/>

Notes: _____

7. CONSIGNES DE SÉCURITÉ IMPORTANTES

Le produit SportsArt a été conçu et fabriqué afin d'assurer une sécurité optimale. Cependant certaines précautions s'appliquent chaque fois que vous utilisez votre produit.

- Lisez entièrement le manuel avant l'assemblage et l'utilisation. Veuillez aussi noter les consignes de sécurité suivantes:
- Veuillez lire attentivement les instructions et installer le produit selon les instructions.
- Assemblez et faites fonctionner le produit sur une surface solide et plane; NE PAS l'utiliser à l'extérieur ou près de l'eau.
- En aucun cas, ne laissez des enfants à proximité ou sur le produit.
- Vérifiez le tapis de course avant chaque utilisation. Assurez-vous que toutes les pièces sont assemblées et que tous les éléments de fixation sont serrés. NE PAS utiliser le produit si l'appareil est démonté de quelque façon.
- Gardez vos mains loin des pièces mobiles.
- Portez des vêtements d'entraînement appropriés; NE PORTEZ PAS de vêtements amples. NE PORTEZ PAS de chaussures à semelles en cuir ou à talons hauts. Attachez les cheveux longs.
- Soyez prudent lors du montage et démontage de l'appareil.
- NE PAS utiliser d'accessoire non spécifiquement recommandé par le fabricant. Car cela pourraient provoquer des blessures ou entraîner une panne de l'appareil.
- Débranchez l'appareil de la prise avant l'entretien ou la suppression de toute pièce.
- Une surveillance étroite est nécessaire quand de produit est utilisé par ou à proximité d'enfants, de malades ou de personnes handicapées.
- Utilisez ce produit uniquement pour l'usage prévu dans ce manuel.
- Ce produit n'est pas destiné à être utilisé par des personnes (y compris des enfants) dont les capacités physiques, sensorielles ou mentales sont réduites ou qui ne disposent pas de l'expérience ou du savoir nécessaires, sauf si celles-ci ont au préalable été formées eu égard à l'utilisation de produit par une personne responsable de leur sécurité.
- Les enfants doivent être encadrés afin d'empêcher qu'ils ne jouent avec le produit.
- Ce produit n'est pas destiné à être utilisé par des personnes (y compris des enfants) dont les capacités physiques, sensorielles ou mentales sont réduites ou qui ne disposent pas de l'expérience ou du savoir nécessaires, sauf si celles-ci ont au préalable été formées eu égard à l'utilisation de ce produit par une personne responsable de leur sécurité.
- Les enfants doivent être encadrés afin d'empêcher qu'ils ne jouent avec le produit.

ATTENTION

Si vous ressentez une douleur ou si vous avez une sensation anormale, ARRÊTEZ VOTRE ENTRAÎNEMENT et consultez immédiatement votre médecin. Entraînez-vous à votre niveau d'exercice recommandé. NE PAS s'entraîner jusqu'à l'épuisement.

- Avant de commencer un programme d'exercice, vous devriez consulter votre médecin. Il est recommandé de faire un examen physique complet.

Dans ce manuel, les mots "gauche" et "droit" sont utilisés en référence aux pièces et au produit. Comme tels, les mots "gauche" et "droit" font respectivement référence aux côtés gauche et droit de l'exerciseur. De même pour plus de concision, le mot «vis» est utilisé dans certains cas où des rondelles, des vis et autres matériels sont associés.

8. APPENDIXES

APPENDIXES Exploded Diagram

Note: We reserve the right to revise the following diagrams at any time without notice or obligation to notify any person of such revisions or changes. Please visit our official website www.gosportsart.com for the latest version.

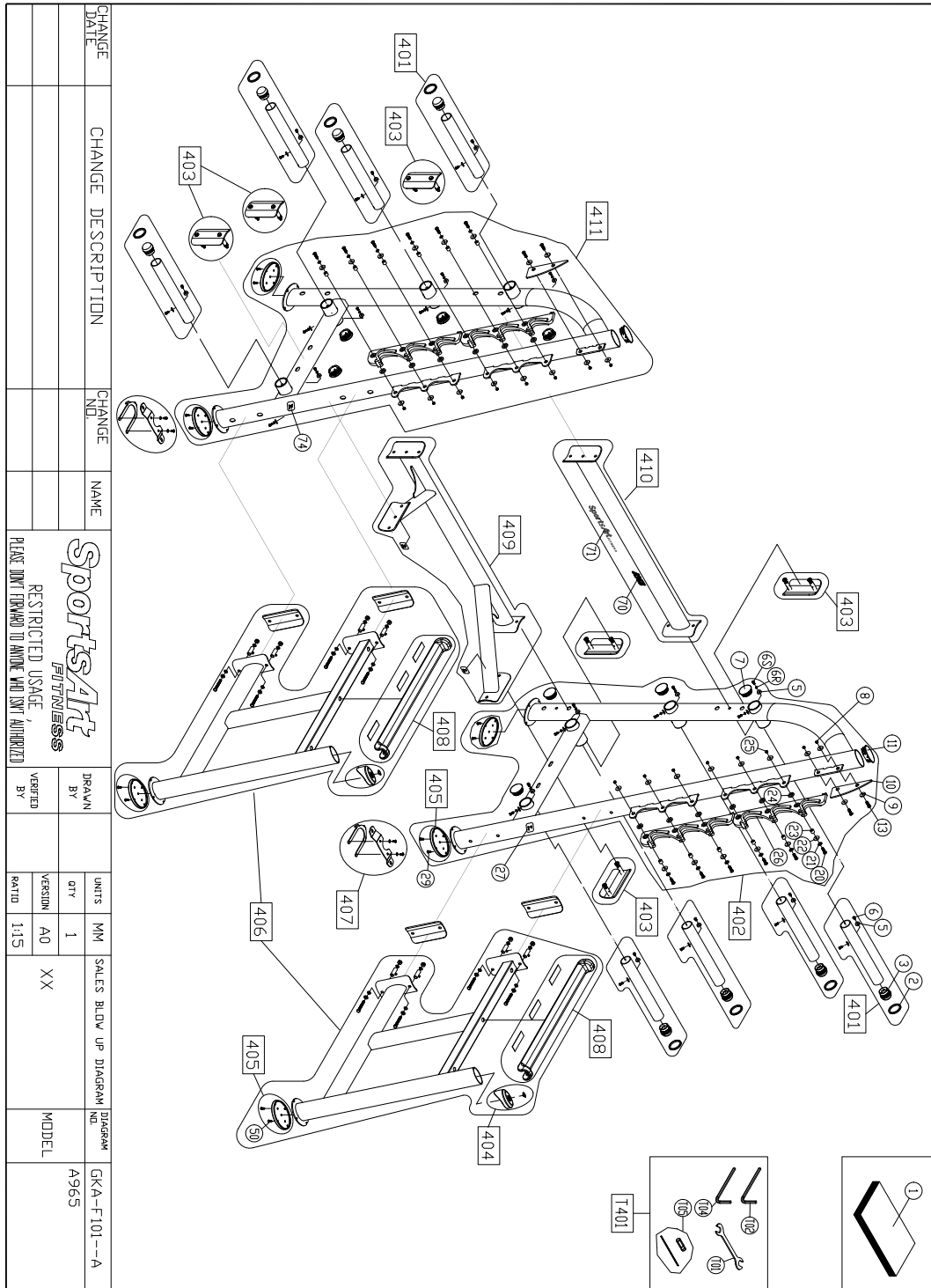

Your Authorized Distributor