

A986 OWNER'S MANUAL CONTENTS

1. INTRODUCTION	2
2. SAFETY PRECAUTIONS	3
3. LIST OF PARTS	4
4. ASSEMBLE THE PRODUCT	6
STEP 1 Install the Seat Base	6
STEP 2 Install the Central Support	7
STEP 3 Install the Arm Assemblies	8
STEP 4 Install the Cushion Adjustment Assembly	9
STEP 5 Install the Seat Bottom Cushion	10
STEP 6 Install the Weight Plate Pegs	11
STEP 7 Level and Secure the Unit	12
5. OPERATE THE PRODUCT	13
OPERATION Safety Operating Area	13
OPERATION Operate the Product	14
6. MAINTENANCE	15
MAINTENANCE Safety Precautions	15
MAINTENANCE Schedule	16
MAINTENANCE Task List	17
MAINTENANCE One-Year Maintenance Log	18
7. CONSIGNES DE SÉCURITÉ IMPORTANTES	19
8. APPENDIXES	21
APPENDIXES Exploded Diagram	21

*We reserve the right to revise this manual at any time without notice.

1. INTRODUCTION

Congratulations on the purchase of a high quality SportsArt product, the A986 lat pulldown machine. Constructed of high quality materials and designed for years of reliable performance, this product was made for full commercial use.

Before this product is assembled or operated, we recommend that you familiarize yourself with this manual. Understanding the correct assembly and operation of this product will help ensure that exercisers obtain their fitness goals safely and successfully.

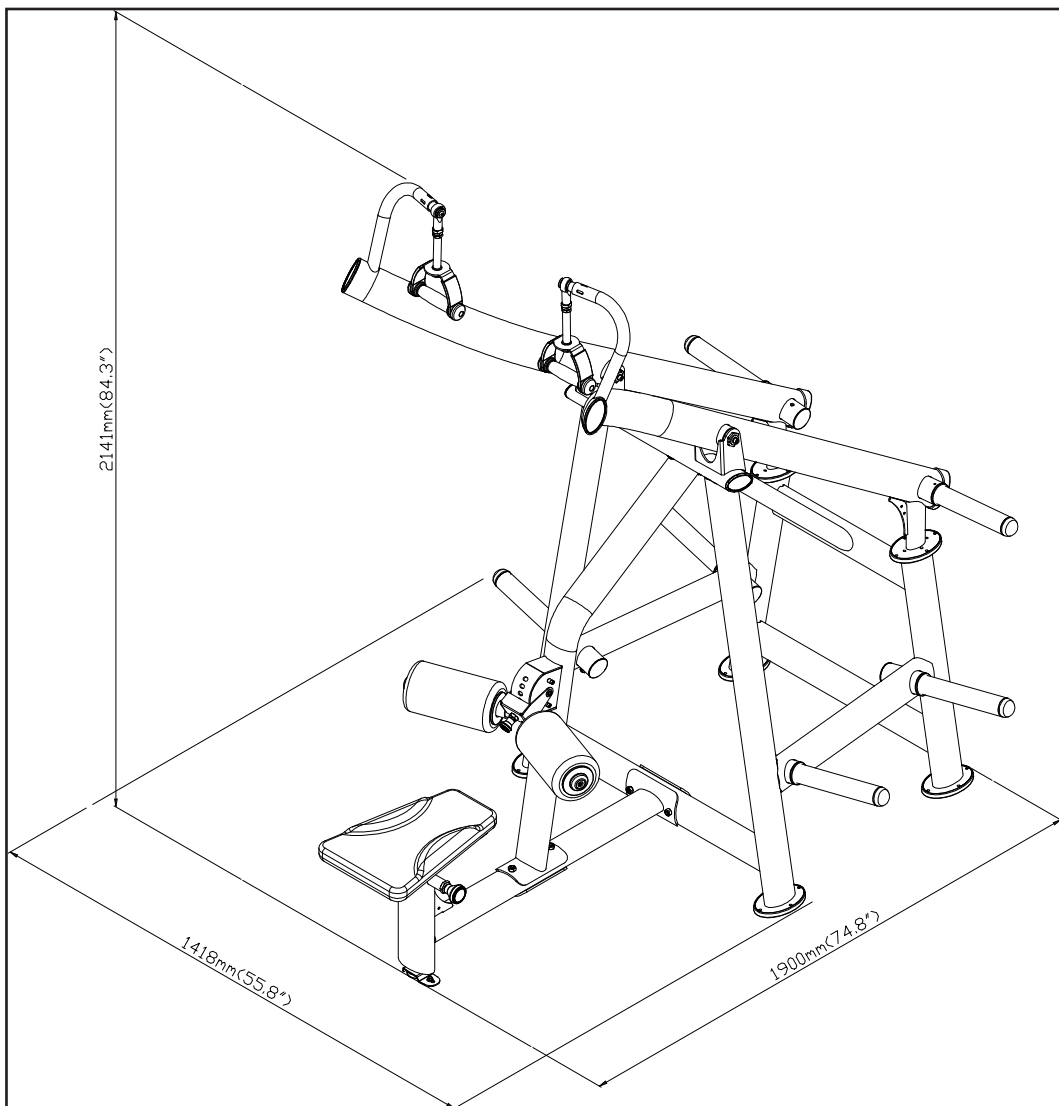

2. SAFETY PRECAUTIONS

This product was designed and built for optimum safety. However certain precautions apply during the use of this product. Please note the following safety precautions:

- Please read the entire manual before assembly and operation. Make sure the product is installed and operated as instructed in this manual.
- Assemble and operate the product on a solid, level surface. Do not use outdoors or near water, including pools and saunas.
- Check the product before every use. Make sure all parts are assembled, and all fasteners are tightened. Do not use the product if it is disassembled in any way.
- Wear proper workout clothing. Do not wear loose clothing. Do not wear shoes with leather soles or high heels. Tie all long hair back. Do not go barefoot on this product.
- Keep away from moving parts. Moving parts may or may not stop immediately if an object becomes caught or impedes normal motion.
- Use this product only for its intended purpose as described in this manual.
- Be careful when mounting and dismounting the unit.
- Never operate this product if it has been damaged in any way. If it is not working properly, or has been dropped or damaged, contact a service technician for repairs.
- Do not use accessories or parts that are not specifically recommended by the manufacturer (SportsArt) . Such parts might cause injuries or cause the unit to fail and void the warranty. We will not be responsible for any safety issue that arises due to the misuse of accessories or parts. At the same time, we will terminate the warranty terms of this equipment.
- This product is not intended for use by persons (including children 12 or younger) with reduced physical, sensory, or mental capabilities, or by people who are otherwise deficient in product knowledge or experience. If such people use this product, they should be given training and be supervised at all times by someone responsible for their safety.
- Contact your SportsArt representatives on all materials damaged in shipment. (Note: Shipping damages are the responsibility of the carrier.)
- Unpack and verify contents of boxes according to the list of parts to check if any parts are missing.
- Children 12 or younger should be supervised to ensure that they do not play on or near the product.
- The user weight limit for this product is 227 kg, 500 lb.
- Maintenance and repair must be performed by trained service personnel only. Improper maintenance would not only damage the machine, but also may present a danger to the exerciser.
- Warning that any of the adjustment devices that could interfere with the user's movement should not be left projecting.
- Over exercise may result in serious injury or death.

CAUTION: If you feel any pain or any abnormal sensations, STOP YOUR WORK-OUT and consult your physician immediately. Work within your recommended exercise level. DO NOT work to exhaustion. Before beginning any exercise program, you should consult with your doctor. It is recommended that you undergo a complete physical examination.

3. LIST OF PARTS

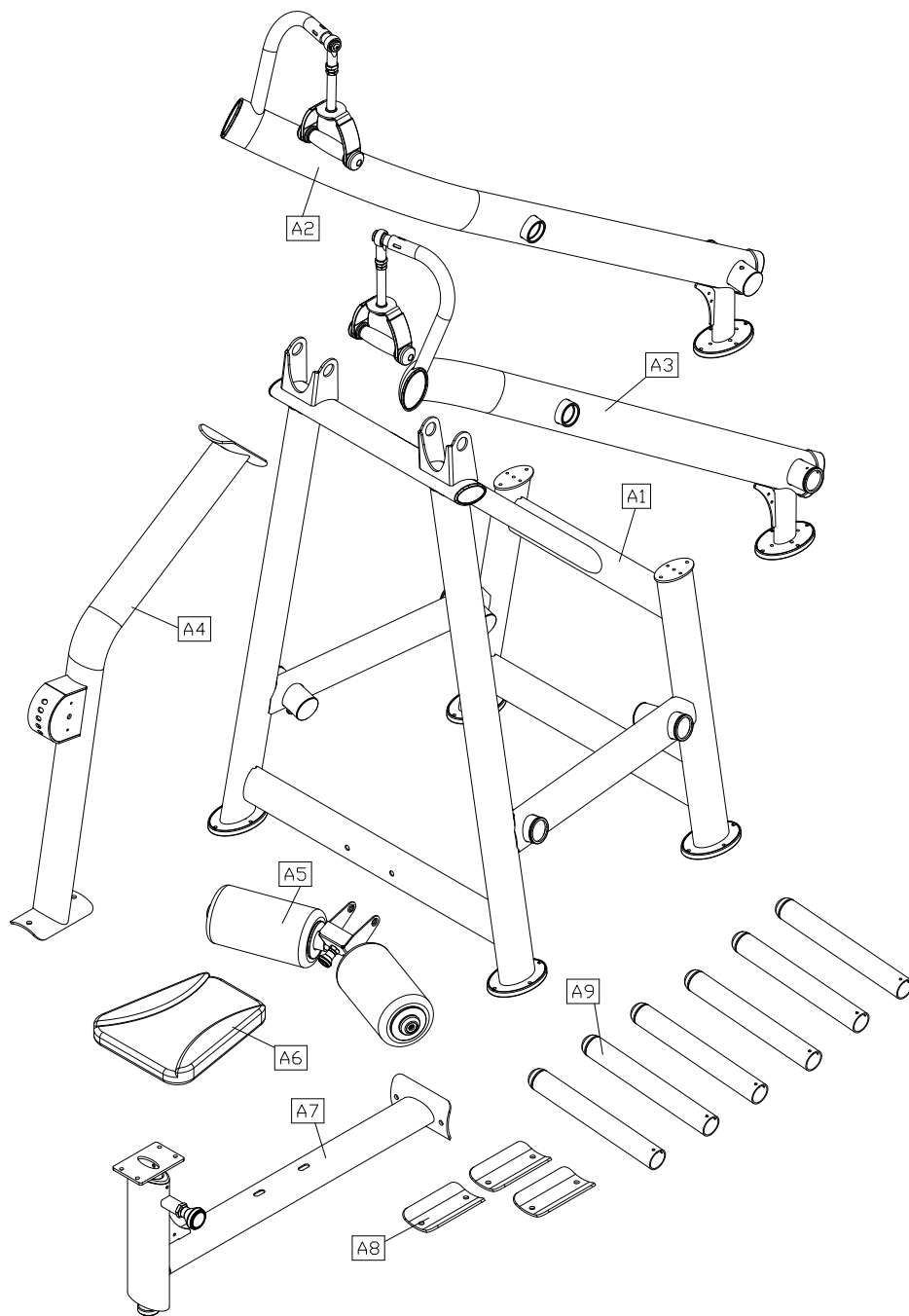

Assembly Parts					
No.	Name	Qty.	No.	Name	Qty.
A1	Main frame	1	A6	Seat bottom cushion	1
A2	Left arm assembly	1	A7	Seat base	1
A3	Right arm assembly	1	A8	Connector	3
A4	Central support	1	A9	Weight plate peg	6
A5	Cushion adjustment assembly	1			

Components on the Product			
No.	Name	Specification	Notes
29	Hex screw	M10*P1.5*L75	
	Spring washer	M10	
	Washer	D16*d10.2*t1.0	
	Bushing	D16*t2*L45.5	
	Lock nut	M10	
30	Inner hex screw	M10*P1.5*L25	
31	Mushroom top inner hex screw	M6*P1.0*L20	
	Spring washer	M6	
	Flat washer	D20*d6.3*t1.5	
	Bushing		
	Axle	ØD6*L73.8 double M6	
32	Mushroom top inner hex screw	M8*L25	
33	Mushroom top inner hex screw	M6*P1.0*L15	
	Handlebar washer	D20*d7*t2.0	
34	Beveled head inner hex screw	M8*P1.25*L20	
	Spring washer	M8	
	Lock nut	M8	
35	Inner hex screw	M6*L10	
	Spring washer	M6	
	Handrail washer	D20*d7*t2.0	

Components in the Hardware Kit				
No.	Name	Qty.	Specification	Notes
15	Floor fixing bracket	1		
	L-shaped Allen wrench	2	M5	
	L-shaped Allen wrench	2	M6	
	L-shaped Allen wrench	1	M4	
	L-shaped Allen wrench	2	M8	
	Double open-end wrench	2	13mm*17mm	
	Open-end wrench	2	35mm	

4. ASSEMBLE THE PRODUCT

Follow instructions below to assemble this product. Note that in this manual the words “left” and “right” are used to refer to the product and its parts. As such, these designations correspond to the “left” and “right” sides of a person in position to exercise on this product. Also, for brevity, the word “screws” or “nuts” is used where washers and other hardware may be involved.

STEP 1 Install the Seat Base

Follow instructions below to install the seat base. First, remove the connector plate (A8) from the main frame (A1). Align the seat base (A7) with the horizontal tube on the front of the main frame (A1). Insert the protruding screws on the connector plate (A8) through the holes in the main frame. Insert the connector into place. Then secure this assembly with nuts (29) as shown.

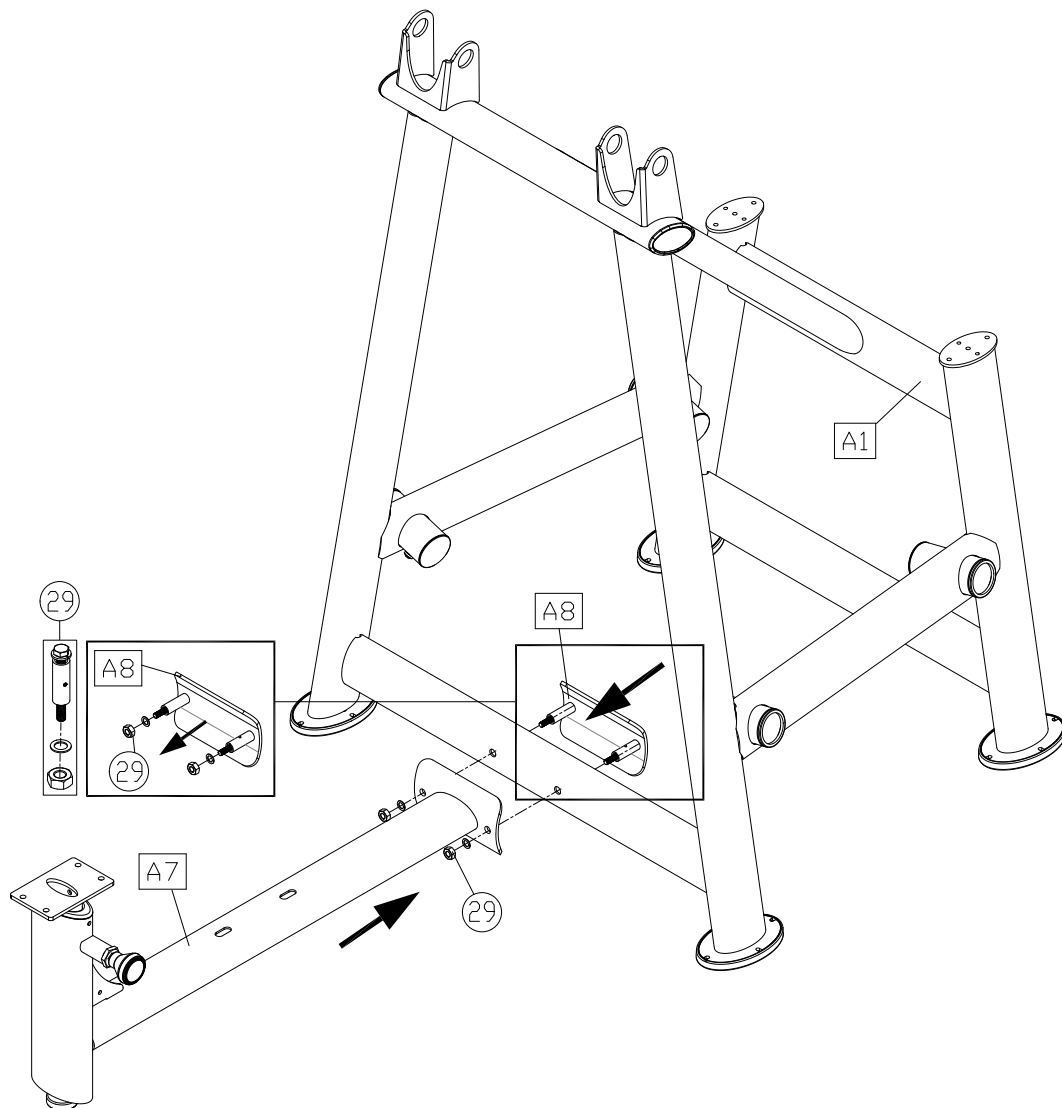

STEP 2 Install the Central Support

Please follow instructions below to secure the central support into place. First, remove the connector plate (A8) from the mainframe (A1) and the seat base (A7). Align the holes in the top of the central support (A4) with those in the seat base (A7) and connect with connector plate (A8). While both areas are aligned properly, hold connectors in place and secure them with nuts (29) as shown.

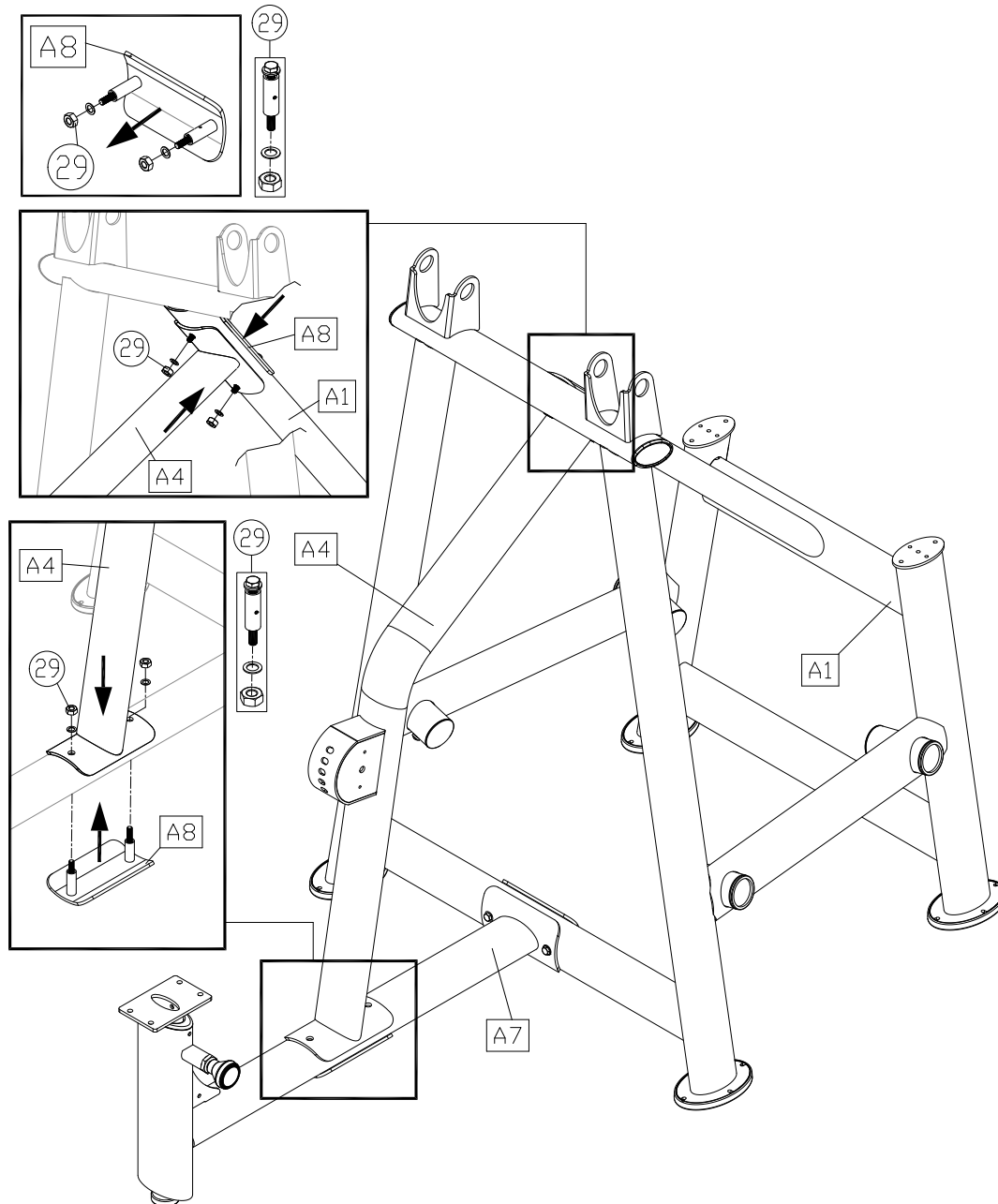

STEP 3 Install Arm Assemblies

Please follow instructions (a) through (b) below to install left and right arm assemblies.

(a) First, remove screws (30) from the main frame (A1).

(b) Align the left arm (A2) to the holes in the main frame (A1). Then use screws (30) to secure the assembly. Carry out the same procedure to install the right arm assembly (A3).

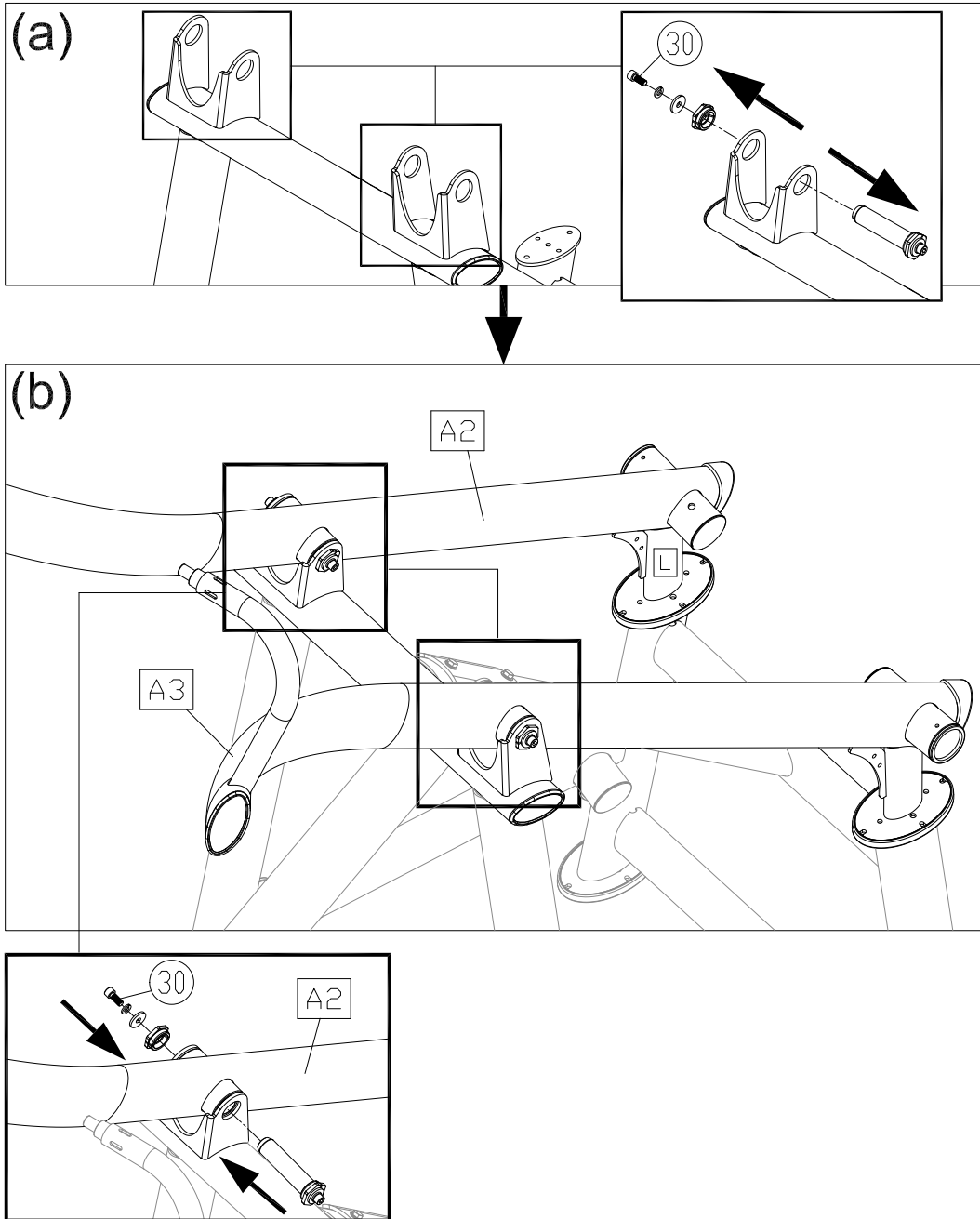

STEP 4 Install the Cushion Adjustment Assembly

Please follow instructions (a) through (b) to install the cushion adjustment assembly.

- (a) Remove the screw assembly (31) in the central support (A4).
- (b) Insert the bushing from the screw assembly (31) into the central support (A4). Then insert the pin into place. Align the cushion support assembly (A5) with the holes in the central support and secure it into place with screws (31).

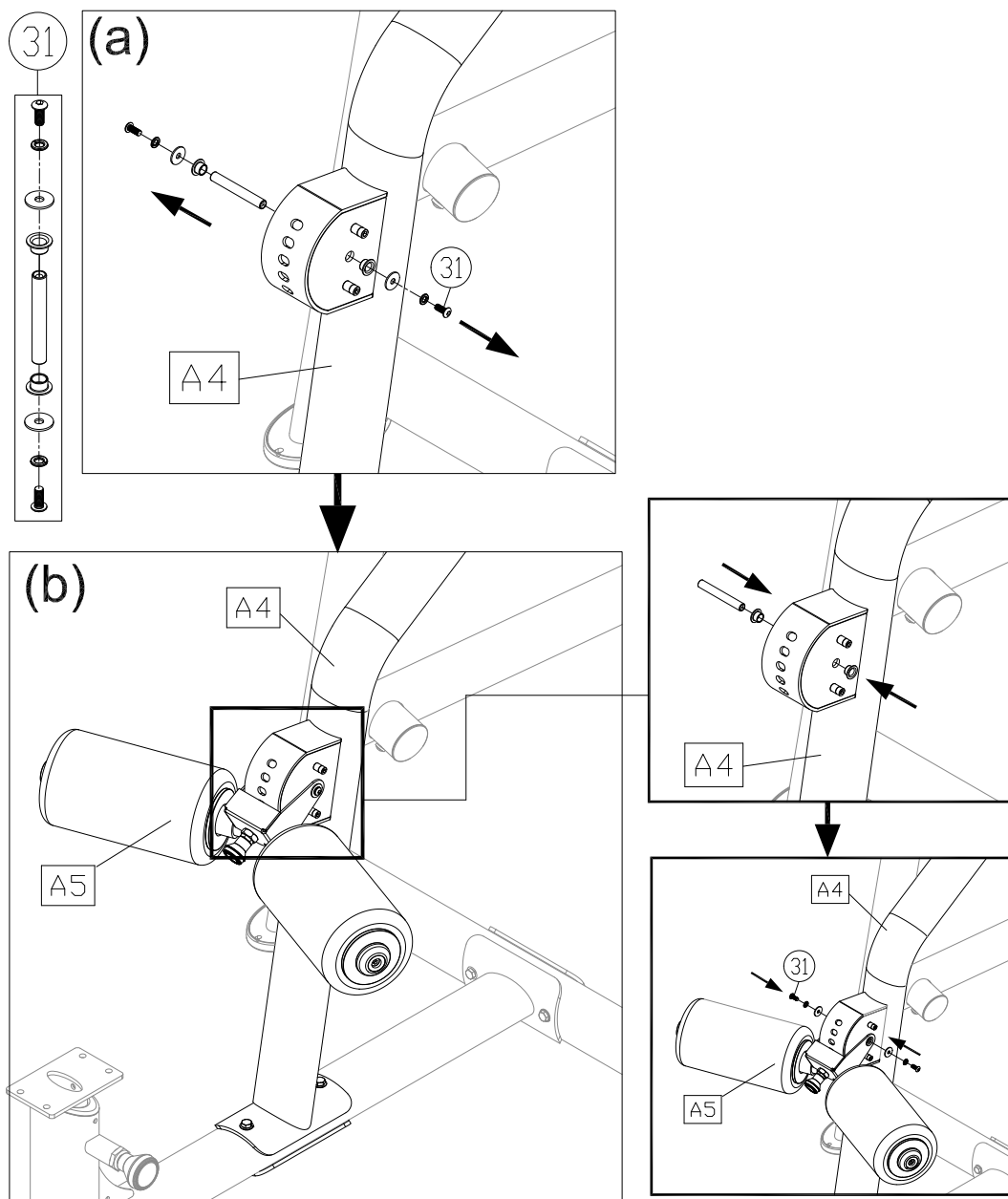

STEP 5 Install the Seat Bottom Cushion

Please follow instructions (a) through (d) to install the seat bottom cushion into place.

- (a) First, remove screws (32) from the seat bottom cushion (A6).
- (b) Then remove the lock screws (34) from the seat base (A7).
- (c) This will free a metal plate from the seat bottom cushion (A6). Use screws (34) to secure the metal plate onto the seat base (A7).
- (d) Place the seat bottom cushion onto the metal plate and secure it into place with screws (32).

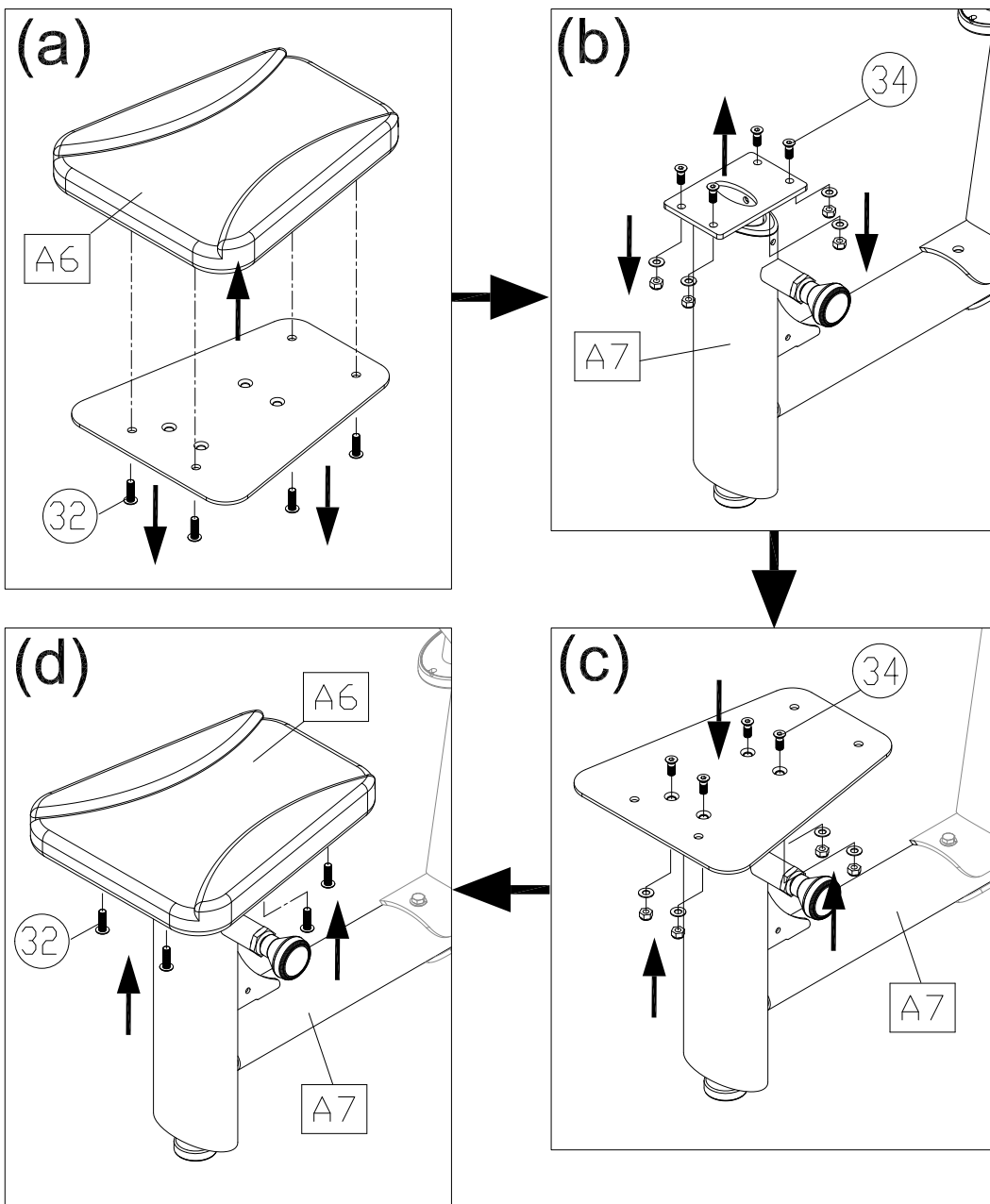

STEP 6 Install Weight Plate Pegs

Please follow instructions (a) through (c) to install weight plate pegs into place.

- (a) First, remove screws (33) from the weight plate pegs (A9).
- (b) Then loosen the screws (35) on both arm assemblies (A2,A3) on the both sides of the main frame (A1). Loosely secure screws (33) through the ends of the weight plate pegs.
- (c) Lastly, secure the whole assembly with screws.

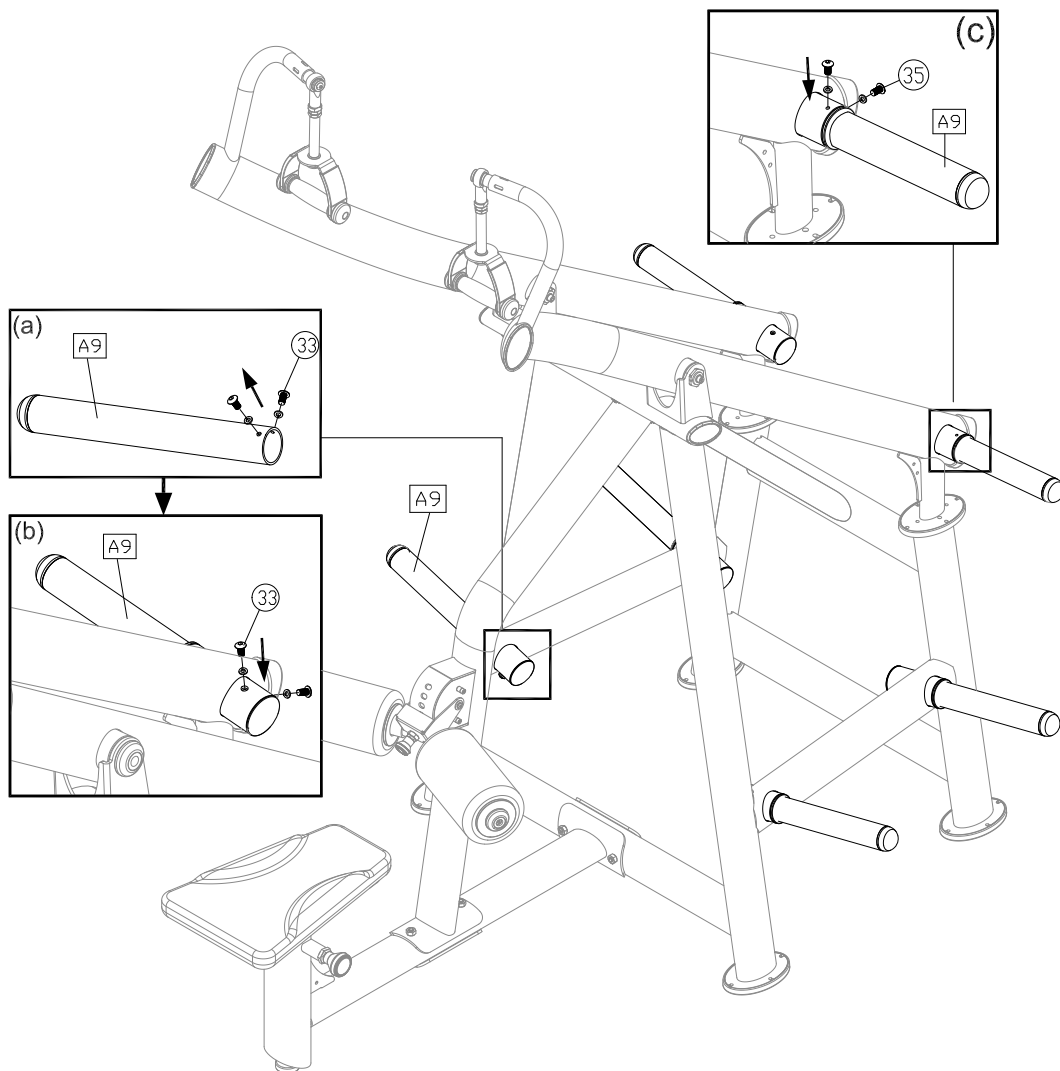

STEP 7 Level and Secure the Unit

Please follow instructions (a) through (d) to level and secure the unit.

- (a) Loosen leveler nuts.
- (b) Rotate the leveler feet downward to the floor.
- (c) Rotate the nuts upward, against the product, to secure this position.
- (d) Secure the floor fixing bracket (15) to the floor with the floor fixing bolt, nut and washer as shown to make sure the machine is firmly fixed to the floor when operating. (Level the machine before securing the floor fixing bolt.)

(Note: The screw hole of floor fixing bracket is $\varnothing 9\text{mm}$, please make sure using the suitable floor fixing bolt and drilling the proper hole on the floor.)

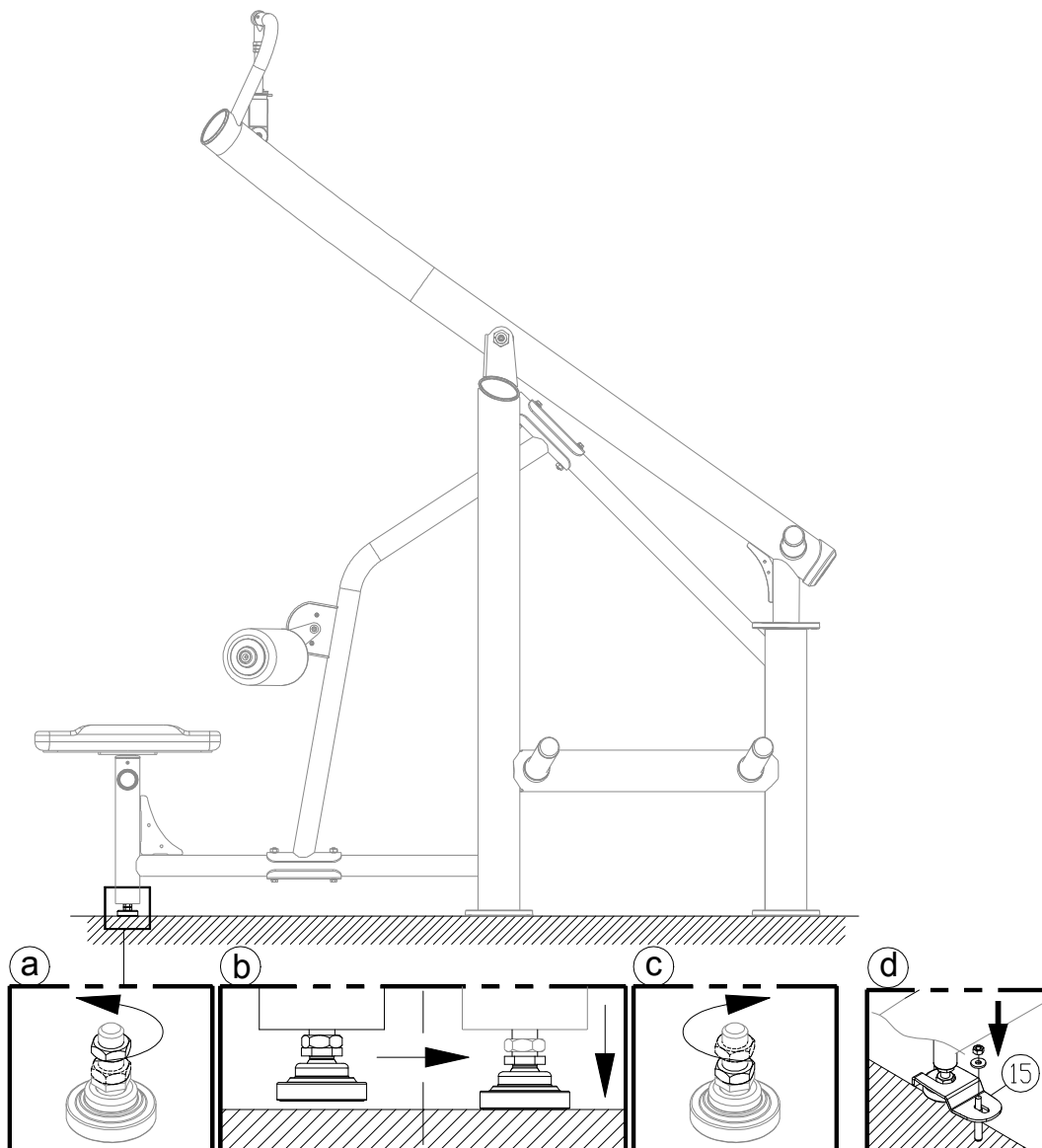

STEP 7 Level and Secure the Unit (Continued)

If the product is installed on an uneven surface to cause the instability of the product, place the support spacer under the foot pad to make sure its stability. (A few support spacers are provided in the packaging of this product.)

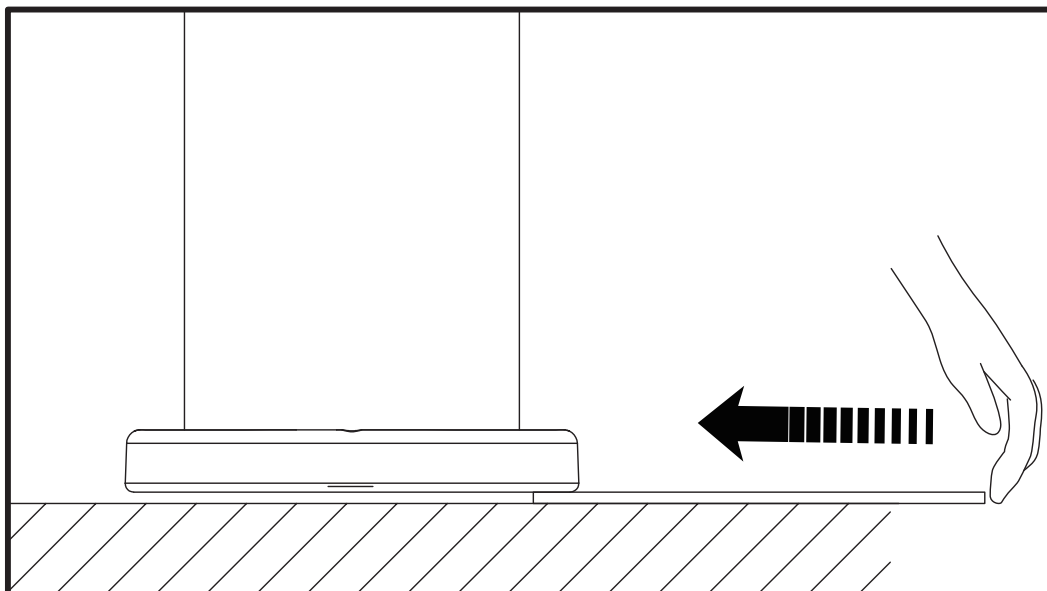

STEP 8 Unit Inspection

After completing the assembly or regular maintenance, please follow instructions (a) through (c) below to inspect the unit. If the unit is disassembled or has been damaged in any way, it might cause injuries or cause the unit to fail.

- (a) Make sure the unit is steady and on a level surface. If the unit is not steady, make adjustments according to the instructions “Level the Unit” of this manual.
- (b) Make sure all parts are assembled and all fasteners are tightened.
- (c) Please follow operating instructions to test operation and confirm that the equipment is working properly. (Please refer to “Operate the Product” of this manual.)

5. OPERATE THE PRODUCT

This section includes operational instructions.

OPERATION Safety Operating Area

- (a) Make sure operate the unit in safety area as shown. Do not allow people to be near this area when operating.
- (b) Noise emission under load is higher than without load.
- (c) Over exercising or improper workout position may result in serious injury.
- (d) This product is intended for exercise back.

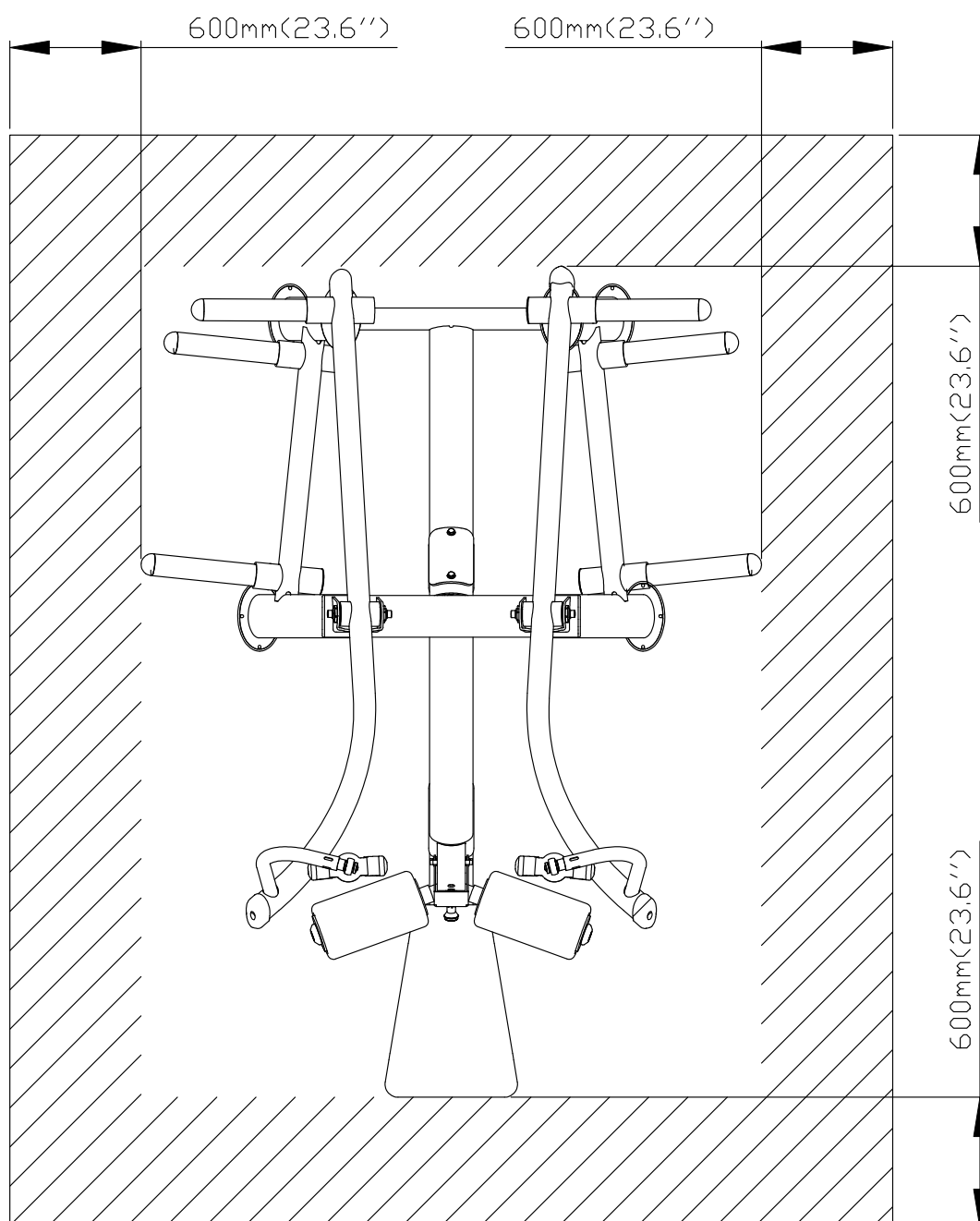

OPERATION Operate the Product

Please follow instructions (a) through (d) to operate the product.

- (a) Select the appropriate weight plates placed on both sides of the weight plates pegs, and then secure the weight plates with safety clamps.
- (b) Adjust the seat height and the cylindrical cushion position, so the thighs are fixed under the cushion.
- (c) Select the position of grip (horizontal or vertical grip).
- (d) Grasp the bar slightly wider than shoulder width and pull down to the upper chest. Exhale slowly back to the original position.

* *Note: While operating the machine, if the weight plate is moving around. Please stop immediately, re-position the weight plate before continuing.*

* *Weight limit: weight plate limit of 200Kg (unilateral 100Kg)*

* *Please exercise within the range of your skill and training.*

* *Operate this machine must be supervised under coaches instructions in order for safety.*

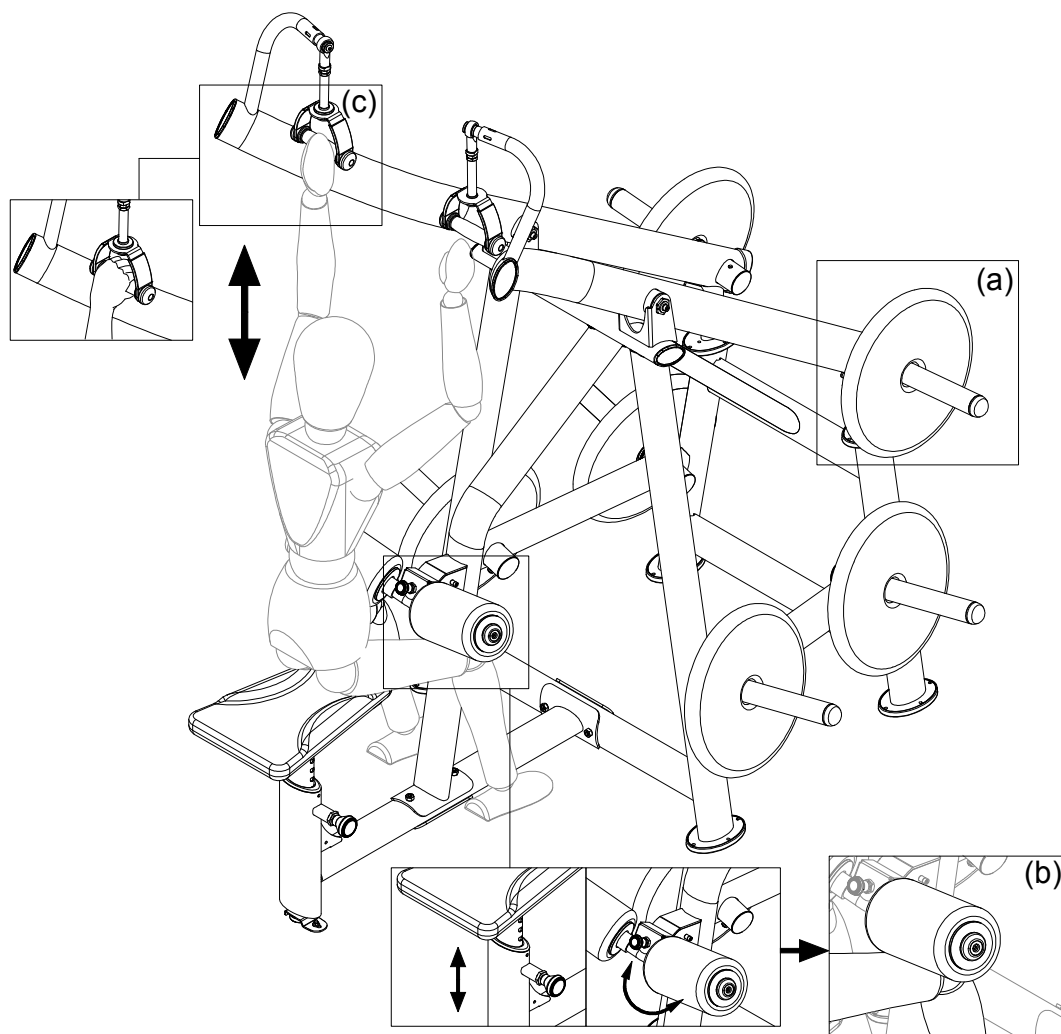

6. MAINTENANCE

This section covers maintenance topics and includes a maintenance schedule, task list, and log.

MAINTENANCE Safety Precautions

- Please follow standard safety precautions when servicing this product.
- Do NOT use a water damp towel to clean the product and do perform the following maintenances.
- Do NOT use cleaners with alcohol, ammonia, or other damaging chemicals. The use of such chemicals can damage the product and void the warranty. Never spray or pour any liquid directly onto the product. Doing so can damage components and void the warranty.
- Use a clean, lint-free towel, dampened with a mixture of Simple Green® all-purpose cleaner, to thoroughly clean the handlebar and the console.
- This product has moving parts that can be hazardous. Exercise caution when maintaining, operating, or moving this product.
- Do not use accessories or parts that are not specifically recommended by the manufacturer (SportsArt) . Such parts might cause injuries or cause the unit to fail and void the warranty. We are not responsible for any safety issue that arises due to the misuse of accessories or parts. At the same time, we will terminate the warranty terms of this equipment.
- Maintenance and repair must be performed by trained service personnel only. Improper maintenance would not only damage the machine, but may also present a danger to the exerciser.
- Keep this product out of use until maintenance is completed.

MAINTENANCE Schedule

If there is a need for maintenance of components, please visit the SportsArt website.

cleaning requirements

1.directive 93/42/CEE

2.directive biocide 98/8/CEE

The disinfectant has to be in compliance with Medical Device Directive 93/42/EEC (MDD) and Biocidal Products Directive 98/8/EC (BPD).

It is suited for sensitive synthetic surfaces such as synthetic leather, polycarbonate (PC), acrylic glass and polysulfone, and for the keyboards and control panels.

	Area	Day	Week	Month	Quarter	Year	Notes
1	Exterior	•					Clean.
2	Screws	•					Inspect for looseness and secure if necessary.
3	Cushions	•					Wipe with a damp cloth.
4	Extension rod				•		Clean and lubricate.

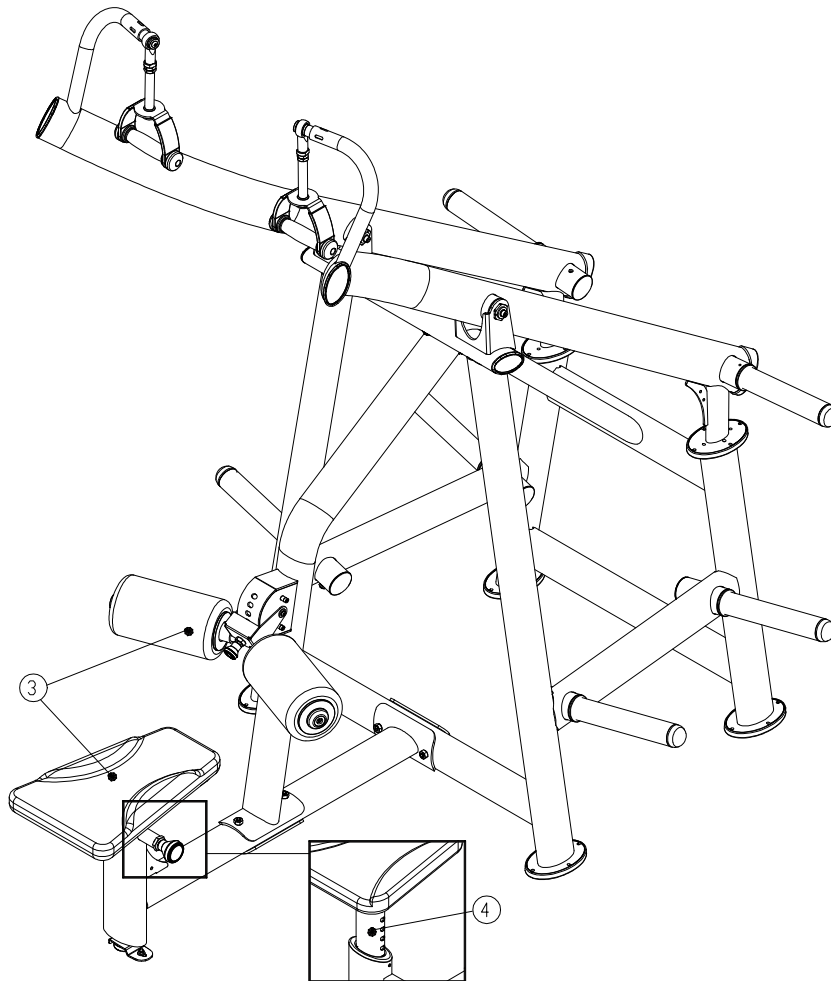

MAINTENANCE Task List

Like cars, fitness products require maintenance. Regular maintenance extends product life, and failure to maintain products can void the manufacturer's warranty. Copy the maintenance log sheet, and record maintenance work for each fitness product.

Daily tasks

1. Use a clean, lint-free towel to wipe down the product exterior.
2. Inspect all screws. Secure if necessary.
3. Wipe cushions clean with a damp cloth.

Quarterly tasks

1. Clean and lubricate extension rods.

Caution

- Please follow standard safety precautions when servicing this product.
- Do NOT use cleaners with alcohol, ammonia, or other damaging chemicals. The use of such chemicals can damage the product and void the warranty. Never spray or pour any liquid directly onto the product. Doing so can damage components and void the warranty.

MAINTENANCE One-Year Maintenance Log

Facility: _____ Supervisor: _____

Product model number: _____ Serial number: _____

Start date: _____ End date: _____

Daily Tasks	Weeks 1-7	Weeks 8-14	Weeks 15-21	Week 22-28
Completed	<input type="checkbox"/>	<input type="checkbox"/>	<input type="checkbox"/>	<input type="checkbox"/>

Daily Tasks	Week 29-35	Week 36-42	Week 43-49	Week 50-52
Completed	<input type="checkbox"/>	<input type="checkbox"/>	<input type="checkbox"/>	<input type="checkbox"/>

Weekly Tasks	Weeks 1-7	Weeks 8-14	Weeks 15-21	Weeks 22-28
Completed	<input type="checkbox"/>	<input type="checkbox"/>	<input type="checkbox"/>	<input type="checkbox"/>

Weekly Tasks	Weeks 29-35	Weeks 35-42	Weeks 43-49	Weeks 50-52
Completed	<input type="checkbox"/>	<input type="checkbox"/>	<input type="checkbox"/>	<input type="checkbox"/>

Monthly tasks	1	2	3	4	5	6	7	8	9	10	11	12
Completed	<input type="checkbox"/>	<input type="checkbox"/>	<input type="checkbox"/>	<input type="checkbox"/>	<input type="checkbox"/>	<input type="checkbox"/>	<input type="checkbox"/>	<input type="checkbox"/>	<input type="checkbox"/>	<input type="checkbox"/>	<input type="checkbox"/>	<input type="checkbox"/>

Quarterly Tasks	Quarter 1	Quarter 2	Quarter 3	Quarter 4
Completed	<input type="checkbox"/>	<input type="checkbox"/>	<input type="checkbox"/>	<input type="checkbox"/>

Yearly Tasks	Year 1
Completed	<input type="checkbox"/>

Notes: _____

7. CONSIGNES DE SÉCURITÉ IMPORTANTES

Le produit SportsArt a été conçu et fabriqué afin d'assurer une sécurité optimale. Cependant certaines précautions s'appliquent chaque fois que vous utilisez votre produit.

- Lisez entièrement le manuel avant l'assemblage et l'utilisation. Veuillez aussi noter les consignes de sécurité suivantes:
- Veuillez lire attentivement les instructions et installer le produit selon les instructions.
- Assemblez et faites fonctionner le produit sur une surface solide et plane; NE PAS l'utiliser à l'extérieur ou près de l'eau.
- En aucun cas, ne laissez des enfants à proximité ou sur le produit.
- Vérifiez le tapis de course avant chaque utilisation. Assurez-vous que toutes les pièces sont assemblées et que tous les éléments de fixation sont serrés. NE PAS utiliser le produit si l'appareil est démonté de quelque façon.
- Gardez vos mains loin des pièces mobiles.
- Portez des vêtements d'entraînement appropriés; NE PORTEZ PAS de vêtements amples. NE PORTEZ PAS de chaussures à semelles en cuir ou à talons hauts. Attachez les cheveux longs.
- Soyez prudent lors du montage et démontage de l'appareil.
- NE PAS utiliser d'accessoire non spécifiquement recommandé par le fabricant. Car cela pourraient provoquer des blessures ou entraîner une panne de l'appareil.
- Débranchez l'appareil de la prise avant l'entretien ou la suppression de toute pièce.
- Une surveillance étroite est nécessaire quand de produit est utilisé par ou à proximité d'enfants, de malades ou de personnes handicapées.
- Utilisez ce produit uniquement pour l'usage prévu dans ce manuel.
- La limite de poids de l'utilisateur pour le produit est de 227 kg, 500 lb.
- Ce produit n'est pas destiné à être utilisé par des personnes (y compris des enfants) dont les capacités physiques, sensorielles ou mentales sont réduites ou qui ne disposent pas de l'expérience ou du savoir nécessaires, sauf si celles-ci ont au préalable été formées eu égard à l'utilisation de produit par une personne responsable de leur sécurité.
- Les enfants doivent être encadrés afin d'empêcher qu'ils ne jouent avec le produit.
- Ce produit n'est pas destiné à être utilisé par des personnes (y compris des enfants) dont les capacités physiques, sensorielles ou mentales sont réduites ou qui ne disposent pas de l'expérience ou du savoir nécessaires, sauf si celles-ci ont au préalable été formées eu égard à l'utilisation de ce produit par une personne responsable de leur sécurité.
- Les enfants doivent être encadrés afin d'empêcher qu'ils ne jouent avec le produit.

7. CONSIGNES DE SÉCURITÉ (SUITE)

ATTENTION

Si vous ressentez une douleur ou si vous avez une sensation anormale, **ARRÊTEZ VOTRE ENTRAÎNEMENT** et consultez immédiatement votre médecin. Entraînez-vous à votre niveau d'exercice recommandé. **NE PAS** s'entraîner jusqu'à l'épuisement.

- Avant de commencer un programme d'exercice, vous devriez consulter votre médecin. Il est recommandé de faire un examen physique complet.

Dans ce manuel, les mots "gauche" et "droit" sont utilisés en référence aux pièces et au produit. Comme tels, les mots "gauche" et "droit" font respectivement référence aux côtés gauche et droit de l'exerciseur. De même pour plus de concision, le mot «vis» est utilisé dans certains cas où des rondelles, des vis et autres matériels sont associés.

Your Authorized Distributor