

**C565U LED Bike
Owner's Manual**



SportsArt

OWNER'S MANUAL CONTENTS

DISCLAIMER.....	3
1.INTRODUCTION.....	4
2.IMPORTANT SAFETY INSTRUCTIONS.....	5
3. LIST OF PARTS.....	10
4. Battery Switch On/Off and Replacement.....	12
5. ASSEMBLE THE PRODUCT.....	13
STEP 0 Unpack the machine.....	13
STEP 1 The Rear Support Installation.....	14
STEP 2 Console Mast Installation.....	16
STEP 3 Console Mast Installation.....	19
STEP 4 The Handlebar Installation.....	20
STEP 5 The Pedal Installation.....	21
STEP 6 The Seat Installation.....	22
STEP 7 Storage tray Installation.....	23
STEP 8 Move the Bike into Place for Use.....	24
STEP 9 Level the Bike.....	25
STEP 10 Ground Wire Installation Instructions.....	26
6. UNDERSTAND LED DISPLAY PANEL.....	27
DISPLAY Overview.....	27
DISPLAY Console Panel.....	27
DISPLAY Windows Display.....	29
DISPLAY Specifications.....	30
DISPLAY Button Function.....	31
7. OPERATE THE PRODUCT.....	33
OPERATION Safe Operating Area.....	33
OPERATION The Seat Adjustment.....	34
OPERATION Get On And Get Off The Bike.....	36
OPERATION Exercising Instructions.....	37
8. PANEL THE PRODUCT.....	38

OPERATION Quick Start Mode	38
OPERATION User Setting Procedure	38
OPERATION Workout Programs	39
OPERATION During Exercise	45
OPERATION Cool Down	45
OPERATION Stop Exercise	45
OPERATION Workout Summary	46
OPERATION Idle Mode	46
OPERATION Auto Power Off Function	46
OPERATION Battery low voltage warning	46
OPERATION Battery charging tips	46
OPERATION User Parameter Setting	47
OPERATION Features	48
9. ABOUT HEART RATE DETECTION	49
HEART RATE Telemetry	49
HEART RATE Contact	50
10. GUIDELINES FOR EXERCISE.....	51
11. MAINTENANCE.....	52
MAINTENANCE Safety Precautions	52
MAINTENANCE Maintenance Checklist	53
MAINTENANCE Maintenance Log	54
MAINTENANCE Disassemble Plastic	55
12. Optional accessories.....	56
Optional accessories SA WELL+ Member System	56
13. APPENDIXES	57
APPENDIXE Specification	57
APPENDIXE Charger Specification	57
APPENDIXE Machine Battery Specification	58
APPENDIXE Error Messages	59
APPENDIXE Electronics Block Diagram	60

DISCLAIMER

The information in this user manual is subject to change without prior notice.

Sports Art Industrial Co., Ltd. makes no representation or warranty of any kind, express or implied, regarding the marketability of this manual, the suitability for a special purpose, or any other matters.

SportsArt Industrial Co., Ltd. accepts no responsibility for any errors in this manual, or any damages incurred directly, indirectly, accidentally, or continually from the modification, display, or other use of this manual.

1.INTRODUCTION

Congratulations on your purchase of one of the finest exercise products on the market today, the SportsArt C565R Bike. Constructed of high-quality materials and designed for years of reliable usage, this product was made to become an integral part of your commercial fitness venue.

Before this product is assembled or operated, we recommend that you familiarize yourself with this manual. Understanding the correct assembly and operation of this product will help ensure that exercisers obtain their fitness goals safely and successfully.

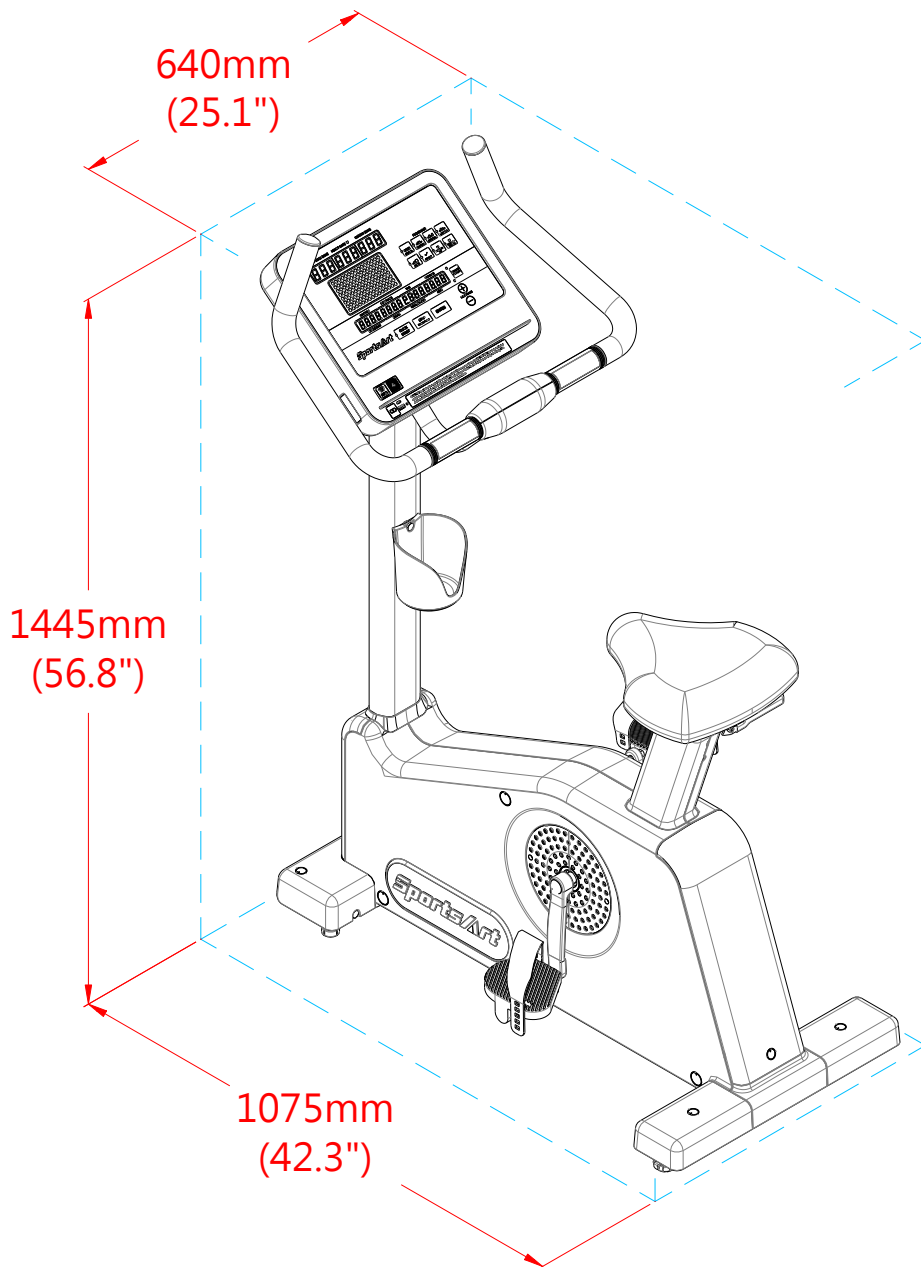

2.IMPORTANT SAFETY INSTRUCTIONS

When using the product, basic precautions should always be followed, including the following:

Read all instructions before using the product.

DANGER – To reduce the risk of electric shock

- Always unplug this product from the electrical outlet immediately after using and before cleaning.

WARNING

※ **To reduce the risk of fire, electric shock, or injury to persons:**

- The product should never be left unattended when plugged in. Unplug from outlet when not in use, and before putting on or taking off parts.
- Do not operate under blanket or pillow. Excessive heating can occur and cause fire, electric shock, or injury to persons.
- This product is not intended for use by persons with reduced physical, sensory, or mental capabilities, or by people who are otherwise deficient in product knowledge or experience. If such people use this product, they should be given training and be supervised at all times by someone responsible for their safety. Keep children under the age of 13 away from this machine.
- Do not let children on or near the product. Children should be supervised to ensure that they do not play with the product.
- Use this product only for its intended use as described in this manual. Do not use attachments or parts not recommended by Sports Art. Such parts might cause injuries or cause the unit to fail and void the warranty. Sports Art will not be responsible for any safety issue that arises due to the misuse of accessories or parts and will terminate the warranty terms of this product.
- Never operate this product if it has a damaged cord or plug, if it is not working properly, if it has been dropped or damaged, or dropped into water. Return the product to a service center for examination and repair.
- Do not carry this product by supply cord or use cord as a handle.
- Keep the cord away from heated surfaces.
- Never operate the product with the air openings blocked. Keep the air openings free of lint, hair, and the like.
- Never drop or insert any object into any opening.
- Do not use outdoors or near water, including pools and saunas.

- Do not operate where aerosol (spray) products are being used or where oxygen is being administered.
- To disconnect, turn all controls to the off position, then remove plug from outlet.
- **WARNING:** Before obtaining access to terminals, all supply circuits must be disconnected.
- Connect this product to a properly grounded outlet only. See Grounding Instructions.
- Before beginning any exercise program, you should consult with your doctor. It is recommended that you undergo a complete physical examination. Have your doctor review your training and diet programs to advise you of a workout routine you should adopt.
- Before using this product to exercise, always do stretching exercises to properly warm up.
- **CAUTION:** If you feel any pain or any abnormal sensations, **STOP YOUR WORKOUT** and consult your physician immediately. Work within your recommended exercise level. **DO NOT** work to exhaustion. Before beginning any exercise program, you should consult with your doctor. It is recommended that you undergo a complete physical examination.
- **WARNING!** Heart rate monitoring systems may be inaccurate. Over exercising may result in serious injury or death. If you feel faint stop exercising immediately.
- Use the product in a supervised environment.
- Any of the adjustment devices that could interfere with the user's movement should not be left projecting.
- The recommended minimum operating temperature is 15 degrees Celsius.
- This product has been tested and found to comply with the limits for a Class B digital device, pursuant to part 15 of the FCC Rules. These limits are designed to provide reasonable protection against harmful interference in a residential installation. This product generates, uses and can radiate radio frequency energy and, if not installed and used in accordance with the instructions, may cause harmful interference to radio communications. However, there is no guarantee that interference will not occur in a particular installation. If the user desires to correct the interference, it is at the user's own expense.
- Noise emission under load is higher than without load.
- **Weight Limit:** Please refer to the product specification table in the Appendix for the maximum weight limit for users of this product.
- The product is intended for commercial use.
- **WARNING:** The product is not suitable for high accuracy purposes.

※ **To reduce the risk of improper operation:**

- Unpack and verify contents of boxes according to the list of parts to check if any parts are missing. If the product is damaged or missing, contact your Sports Art representative to find out all the materials that were damaged during shipping. (Note: Transport damage is the responsibility of the carrier.)
- Make sure the product is installed and operated as instructed in this manual. Be careful when mounting and dismounting the unit. The product shall be disconnected from its power source during service and installed and when replacing parts.
- Check the product before every use. Make sure all parts are assembled, and all fasteners are tightened. Do not use the product if it is disassembled in any way.
- This product has moving parts that can be hazardous. Exercise caution when maintaining, operating, or moving this product. Keep away from moving parts. Moving parts may or may not stop immediately if an object becomes caught or impedes normal motion.
- Assemble and operate the product on a solid, level surface.
- This product should be positioned away from walls to avoid injury due to falls. Be sure that the back of the product has at least six to seven feet of clearance from a ledge, wall or window. The power supply and wiring should be located away from walking paths or taped to prevent tripping when getting on and off the product.
- Wear proper workout clothing. Do not wear loose clothing. Do not wear shoes with leather soles or high heels. Tie all long hair back. Do not go barefoot on this product.
- Never spray or pour any liquid directly onto the product. Lidded containers are recommended and place in a bottle holder.
- Press “STOP” to stop the product.

※ **To reduce the risk of improper maintenance and storage:**

- **WARNING!** Only qualified technicians should be allowed to contact electrical components such as circuit boards. Some components carry an electrical charge even after use has been discontinued or the product has been unplugged. For products with power cords, turn off unit power, wait 10 minutes, then disconnect the power cord from the power socket. For products without power cords, let the unit sit without use for 10 minutes. Only after taking such precautions should covers be removed and electrical components be accessed.
- The effect that the safety level of the product can be maintained only if it is examined regularly for damage and wear, e.g., ropes, pulleys, connection points.
- Replace defective components immediately and keep the product out of use until repair.

- Special attention to components most susceptible to wear.
- If the supply cord is damaged, it must be replaced by a cord available from the manufacturer.

SAVE THESE INSTRUCTIONS

MARKINGS

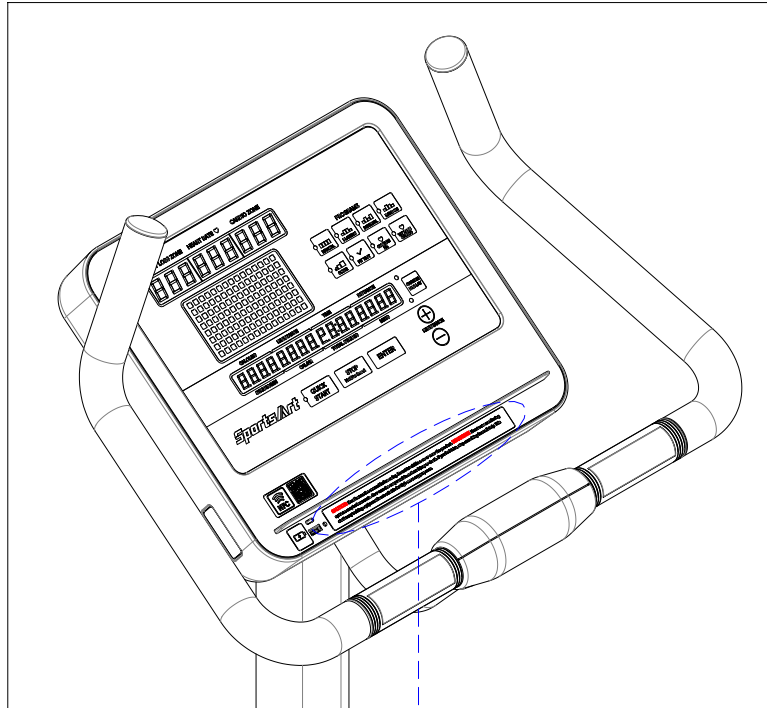

CAUTION: Read instruction manual before using. Do not let children on or near the product. **WARNING!** Heart rate monitoring systems may be inaccurate. Over exercise may result in serious injury or death. If you feel faint, stop exercising immediately. This stationary training equipment is not suitable for high accuracy purposes.

CAUTION:

(Console)

- Read instruction manual before using.
- Do not let children on or near the product.
- To reduce the risk of injury from moving parts or electric shock, unplug before cleaning or servicing.

WARNING:

- Heart rate monitoring system may be inaccurate.
- Over exercise may result in serious injury or death.
- If you feel faint, stop exercising immediately.
- This stationary training equipment is not suitable for high accuracy purposes.

3. LIST OF PARTS

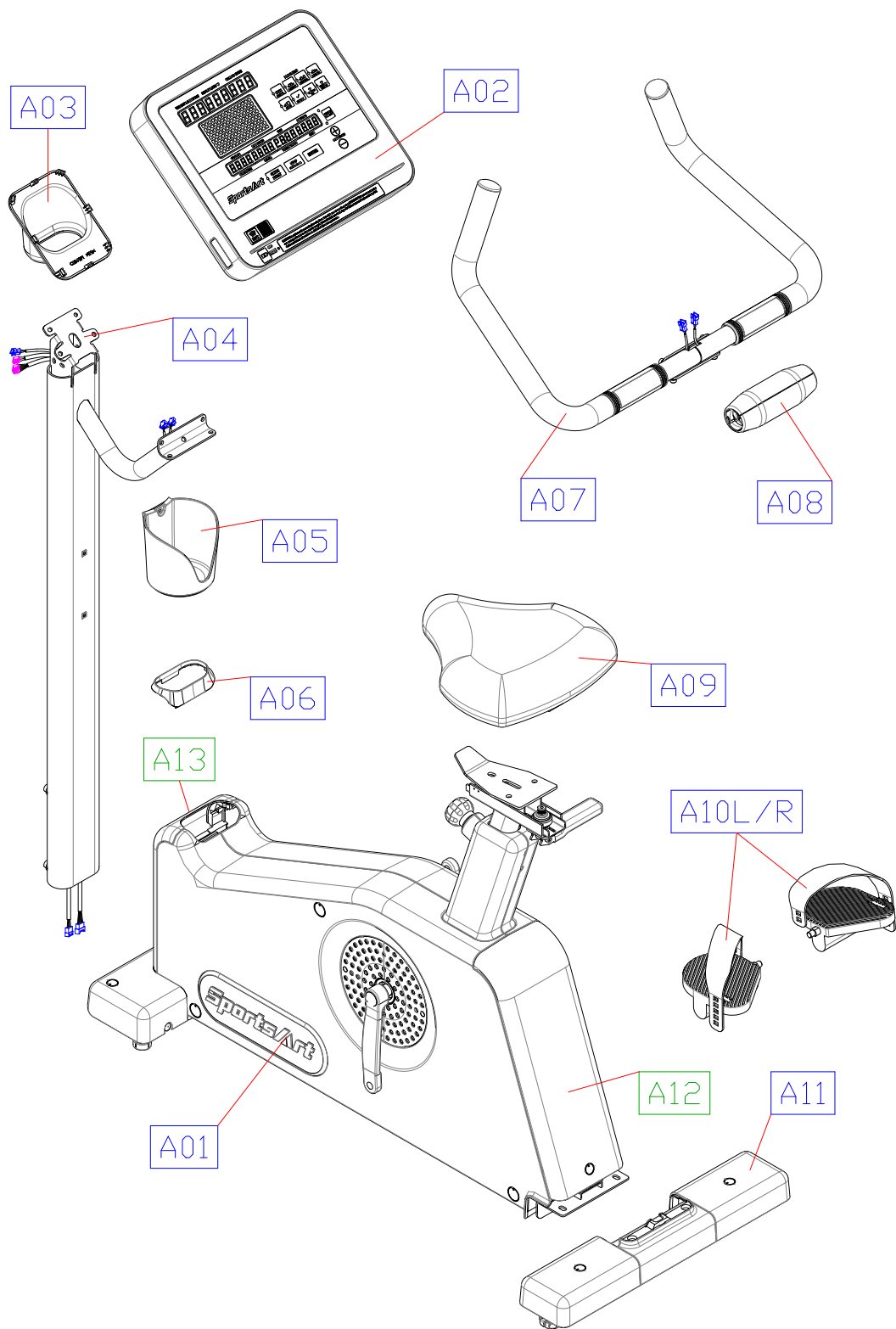

3. LIST OF PARTS (Cont.)

Assembly Parts					
NO.	Name	Qty.	NO.	Name	Qty.
A01	Main frame	1	A08	Handlebar Cover(Upper/Lower)	1
A02	Display Panel	1	A09	Seat	1
A03	Neck cover	1	A10L/R	Left/right pedal	1
A04	Console mast	1	A11	Rear Support	1
A05	Storage tray	1	A12	Back cover	1
A06	Console mast cover	1	A13	Front cover	1
A07	Handlebar				

Assembly parts (Including hardware kit)				
※ Hardware kit note T ; Components on the product note M				
NO.	Name	Qty.	Specification	Notes
	Dual-Use screwdriver	1	Phillips and flat	T
	L-shaped Allen wrench	1	M6*L70	T
	L-shaped Allen wrench	1	M5*L70	T
	T-shaped Allen wrench	1	M5*L102mm	T
	Double open-ended wrench	1	13mm*15mm	T
16	Plastic fastener	2		T (Spare)
17	Screw socket	2	SGN-07	T (Spare)
18	Cap nut	2		T
	Mushroom top phillips screw	2	D18*d8.5*t2.0*19T	
19	Ground wire group	1		T
20	Mushroom top phillips screw	8	M4*L14	T
21	Phillips screw	2	M5*P0.8*L12	M
	Cap nut	2	TBX-P155	
22	Umbrella hex screw	8	M8*P1.25*L25	M
	Flat washer	8	D17*d8*t1.5	
	Screw washer	4	§ D13*d7	
	Washer	4	D40*d8.5*t3.0	
	Nylon nut	4	M8*P1.25	
23	Zip tie	1		M
24	Umbrella hex screw	4	M8*P1.25*L15	M
	Toothed lock washer	4	D18*d8.5*t2.0	
25	Umbrella hex screw	4	M6*P1.0*L12	M
	Flat washer	4	D16*d6.3*t2	
26	Umbrella hex screw	4	M6*P1.0*L12	M
	Flat washer	4	D13*d6.5*t1.0	
27	Washer	3		
	Nut	3		

4. Battery Switch On/Off and Replacement

- ※ After finishing the assembly, turn on the battery switch. Please make sure the battery switch is turned on before using the unit.
- ※ This unit is self-powered equipment. The battery switch is to reduce battery consumption and to prevent overdischarge from shortening battery life. If the battery switch is off during use, the unit may be operable, but there will be abnormalities.
- ※ After the battery is enabled, the normal lifespan is 1.5 years. The battery life and lifespan will be reduced depending on the degree of use.
- ※ Turn off the battery switch when the unit is not used for a long time.
- ※ If the battery has no power, users need to purchase a charger with appropriate specifications when charging it by themselves.

【Refer to Machine Battery Specification in 13.Appendixes for battery specifications.】

Instructions for the battery replacement:

- (a). Turn off the battery switch and remove the access cover of the mainframe.
 - (b). Unplug the cables (red/black) of the battery.
 - (c). Disassemble the battery holder (green) from the unit and remove the old battery.
 - (d). Install the new battery in the battery holder (green), secure it to the unit, and then reconnect the cables.
 - (e). Install the access cover and turn on the battery switch.
- ※ The red end is attached to the positive terminal (+, red), and the black one is attached to the negative terminal (—, black).

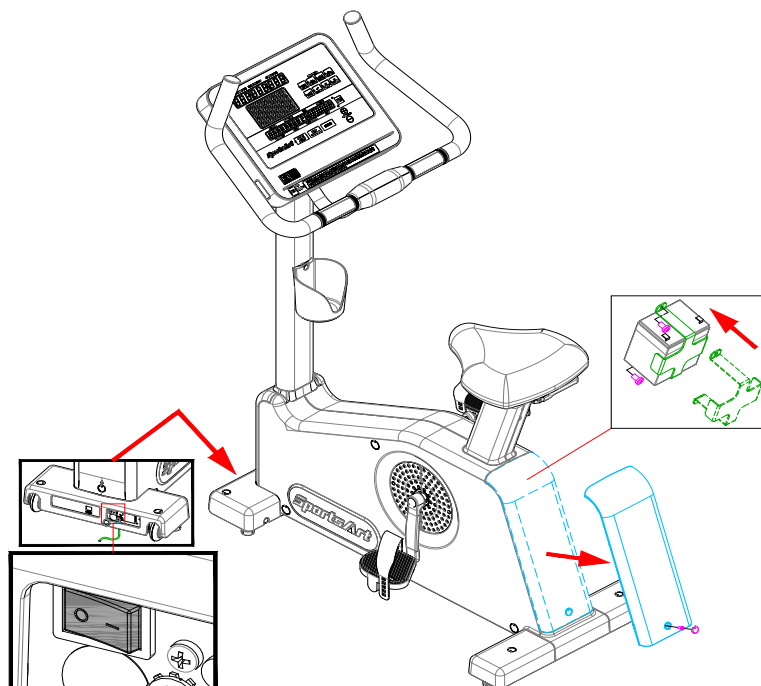

5. ASSEMBLE THE PRODUCT

Follow instructions below to assemble this product. Note that in this manual the words “left” and “right” are used to refer to the product and its parts. As such, these designations correspond to the “left” and “right” sides of a person in position to exercise on this product. Also, for brevity, the word “screws” or “nuts” is used where washers and other hardware may be involved.

STEP 0 Unpack the machine

Before assembling, please unpack the equipment, take out all the related accessories, and then lift the machine up as shown.

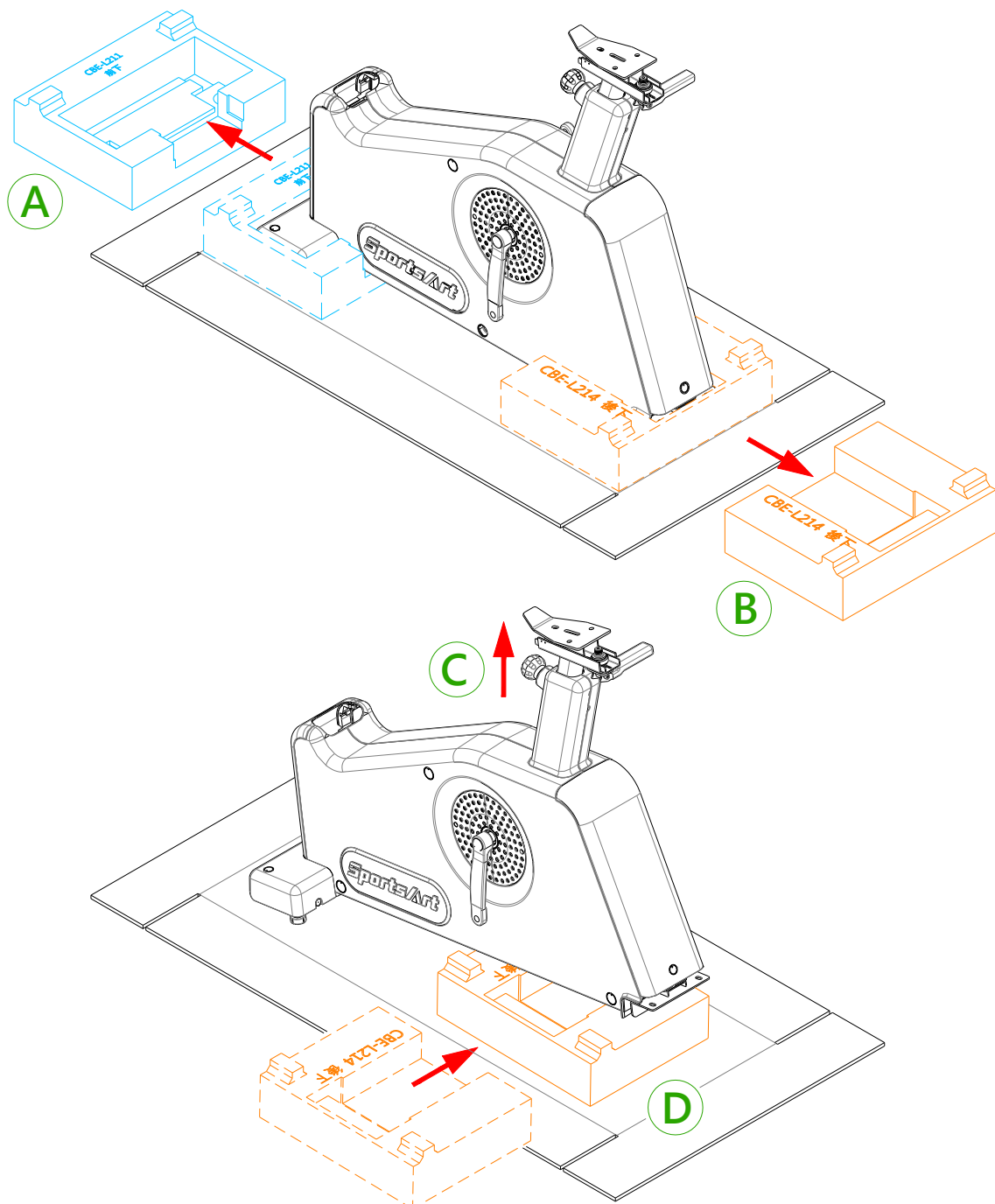

STEP 1 The Rear Support Installation

- (a). Remove the screws (21) and back cover (A12) from the main frame (A01)
- (b). Secure the rear support (A11) with the screws (22) to the main frame (A01).

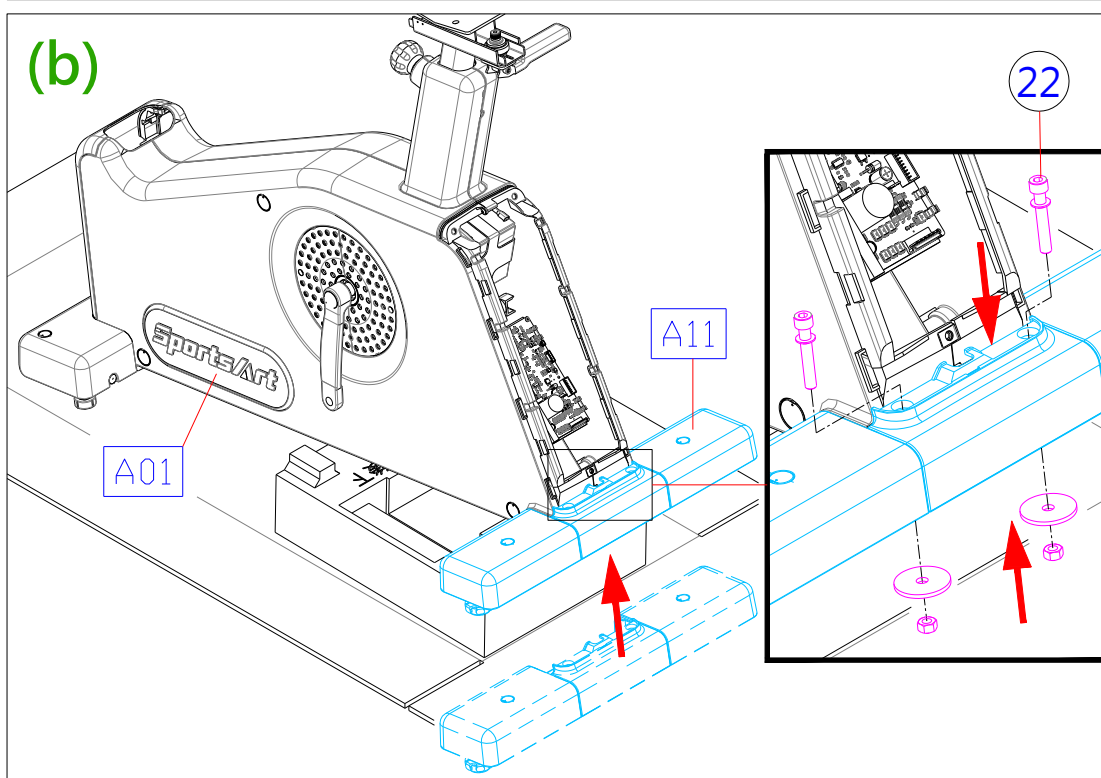
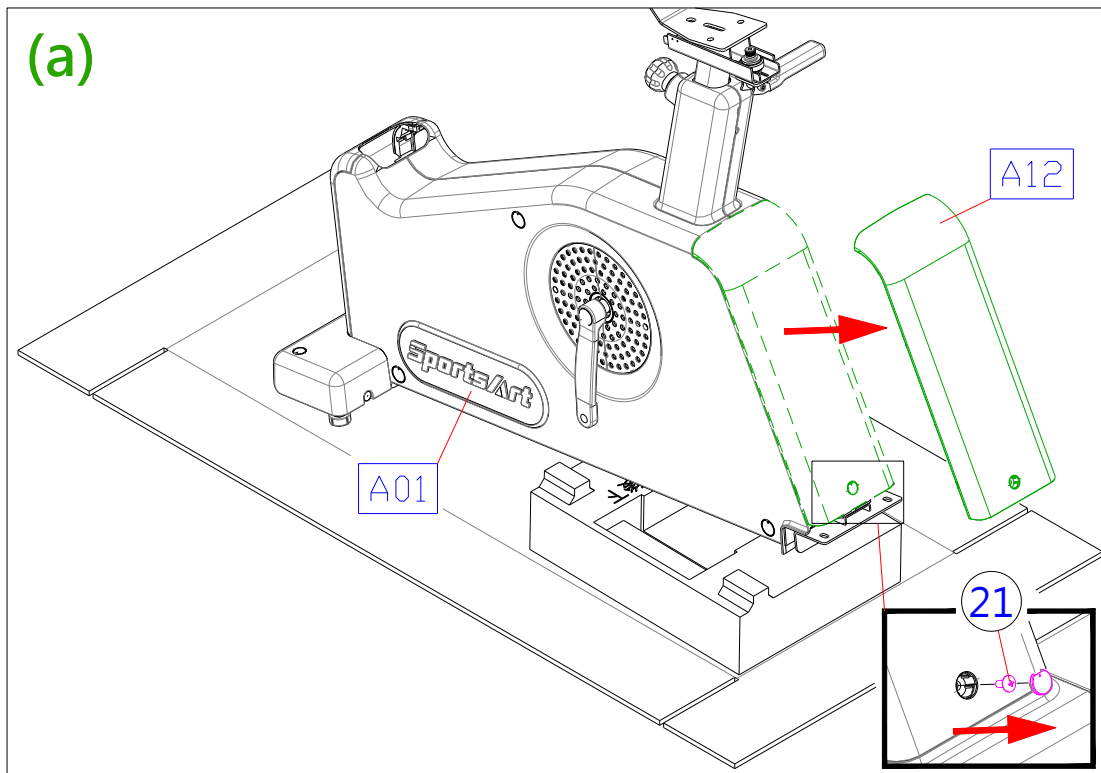

STEP 1 The Rear Support Installation (Cont.)

(c). Reinstall the back cover (A12) with the screws (21).

※. Be sure plastic fasteners (16) are in place (A).

(d). Lift the machine up again, then remove package material.

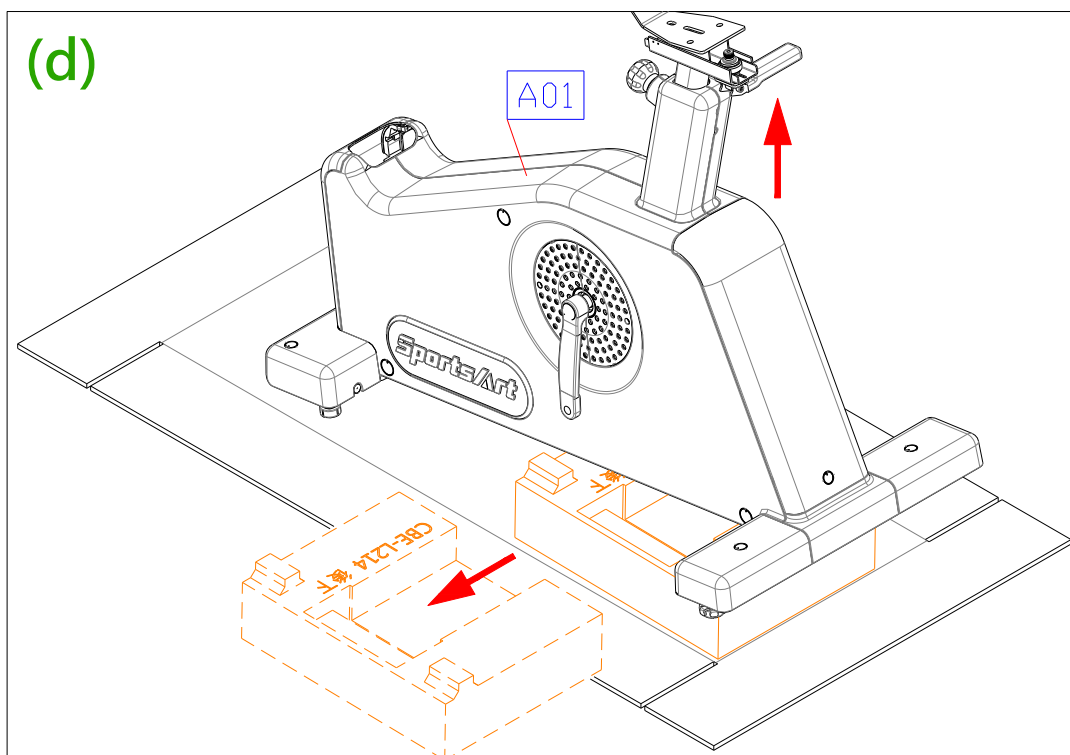
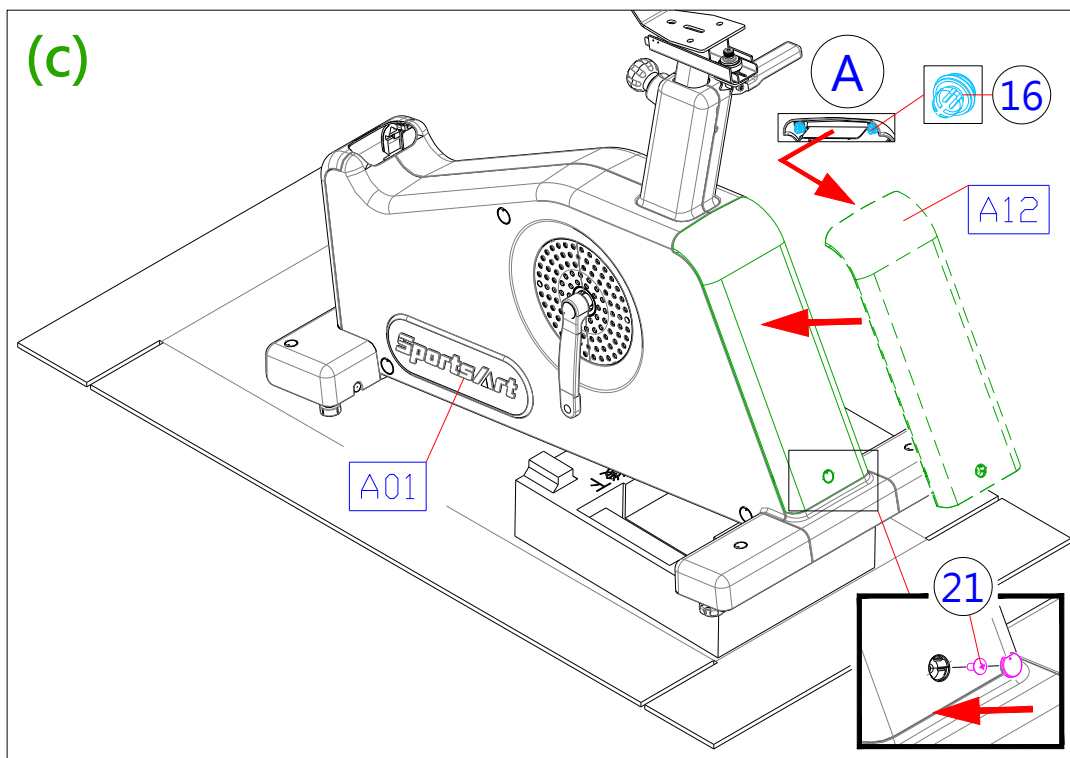

STEP 2 Console Mast Installation

- (a). Remove the front cover (A13) and the screws (21) from the mainframe (A01).
- (b). Insert the console mast cover (A06) through the bottom of the console mast (A04). (Please note the direction of the console mast cover.)

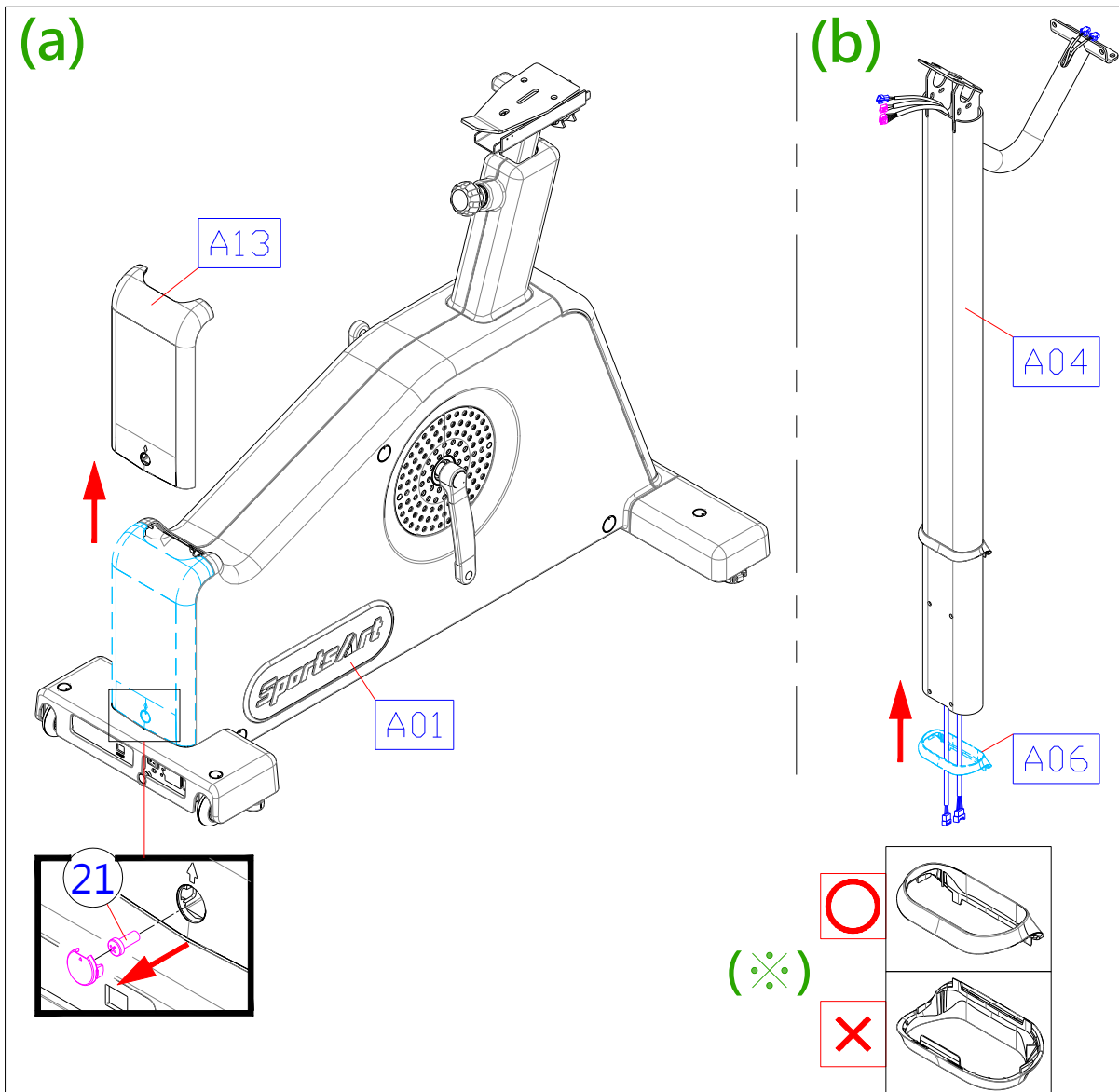

STEP 2 Console Mast Installation (Cont.)

(c). Follow the following steps:

- (i). Wrap the zip tie (23) around the data cable in the console mast (A04).
- (ii). Thread the zip tie wrapped around the data cable out the bottom of the iron plate of the mainframe (A01) fixing the console mast.
- (iii). Insert the console mast (A04) into the iron plate of the mainframe (A01) fixing the console mast and pull out the data cable.
- (iv). Connect the data cable in the console mast to that in the mainframe, and then put them into the mainframe (A01).

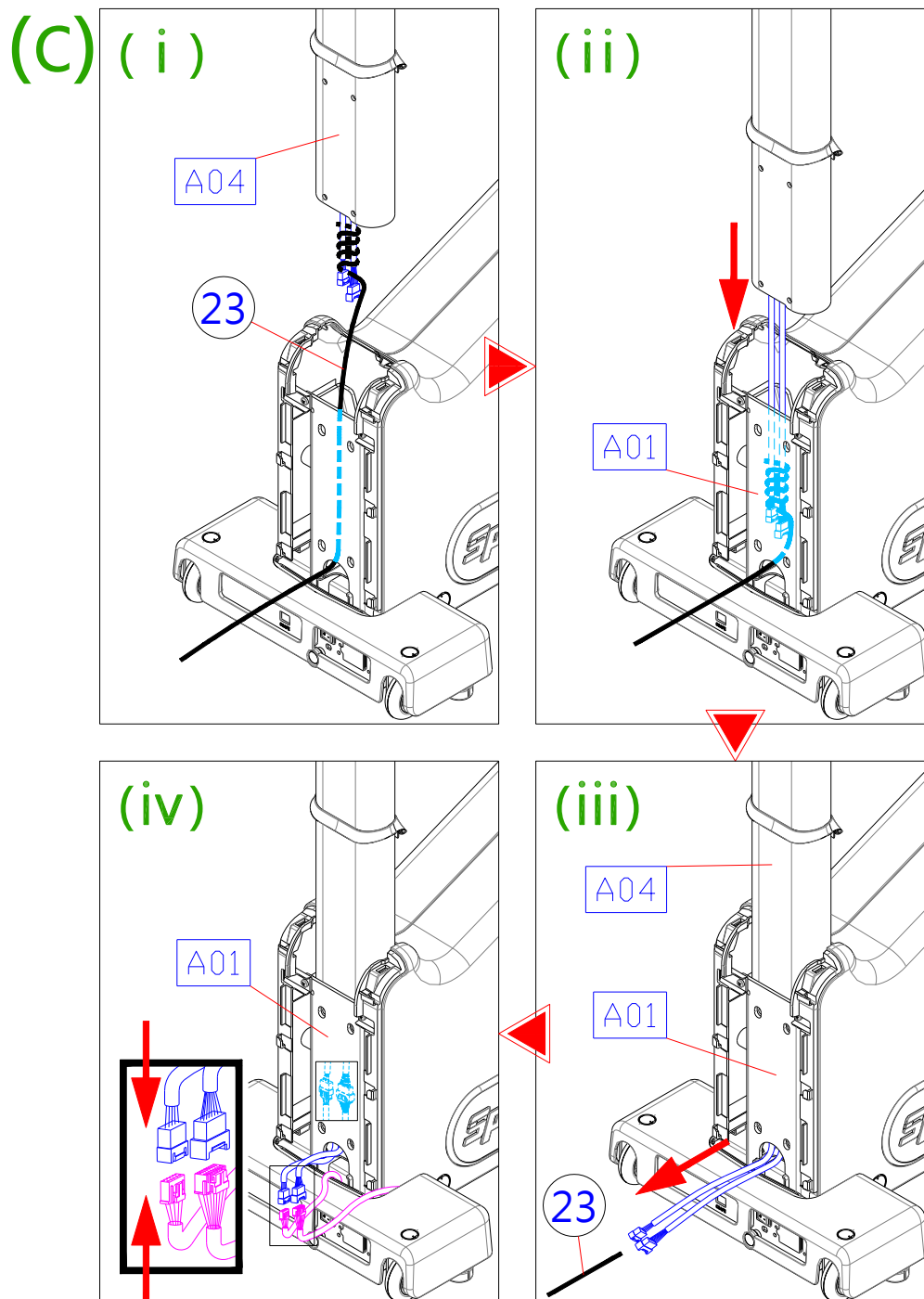

STEP 2 Console Mast Installation (Cont.)

- (d). Secure the console mast (A04) to the mainframe (A01) with the screws (24).
- (e). Secure the front cover (A13) to the mainframe (A01) with the screws (21).
- (f). Install the console mast cover (A06) between mainframe (A01) and the front cover (A13).

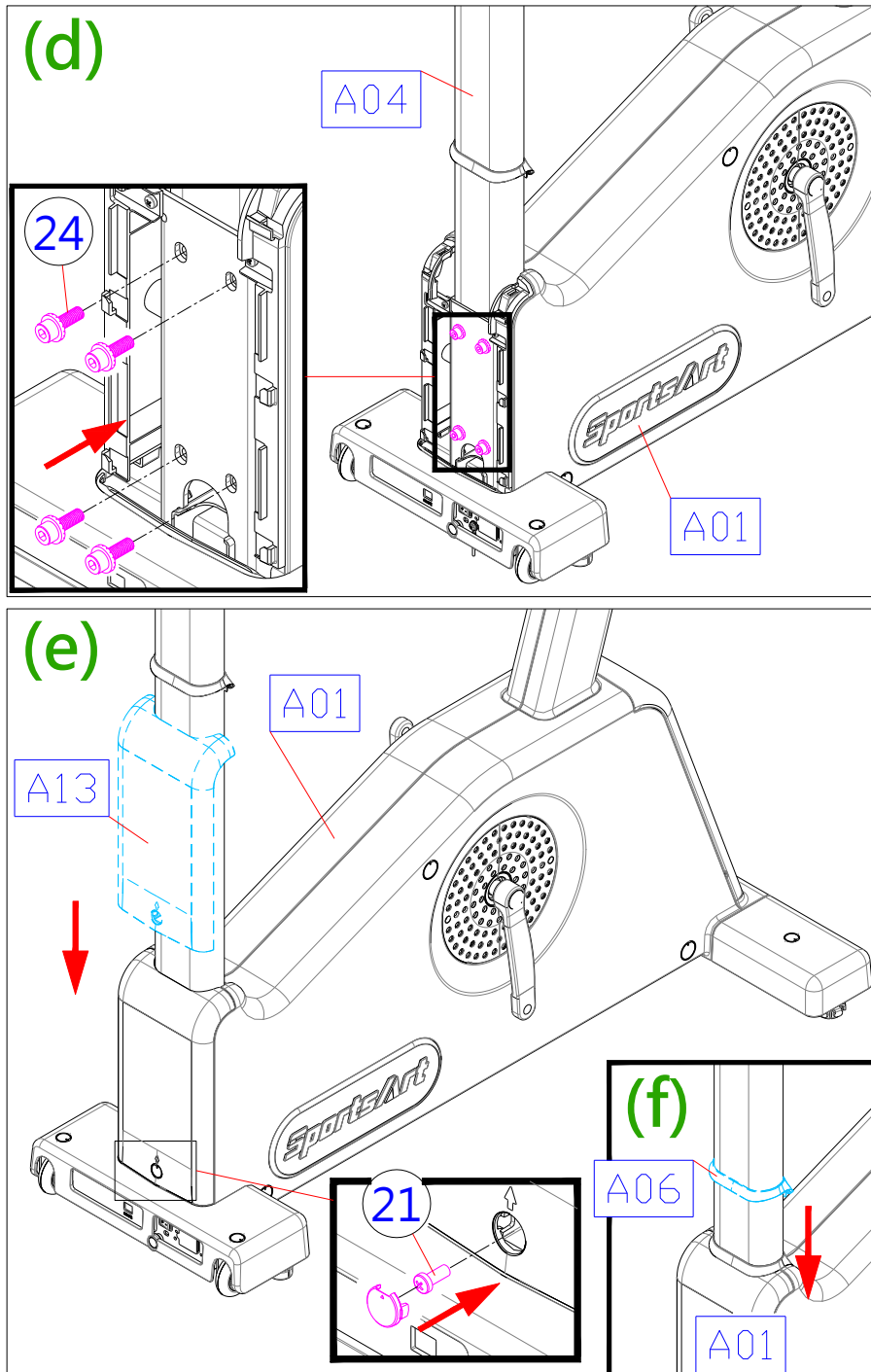

STEP 3 Console Mast Installation

- (a). Insert the neck cover (A03) onto the console mast (A04).
- (b). After connect the data cable of the display panel (A02) to that in the console mast (A04), and then put them into the opening.
- (c). Attach the display panel (A02) to the console mast (A04) with the screws (25).
- (d). Press the console mast cover (A03) into the display panel (A02).

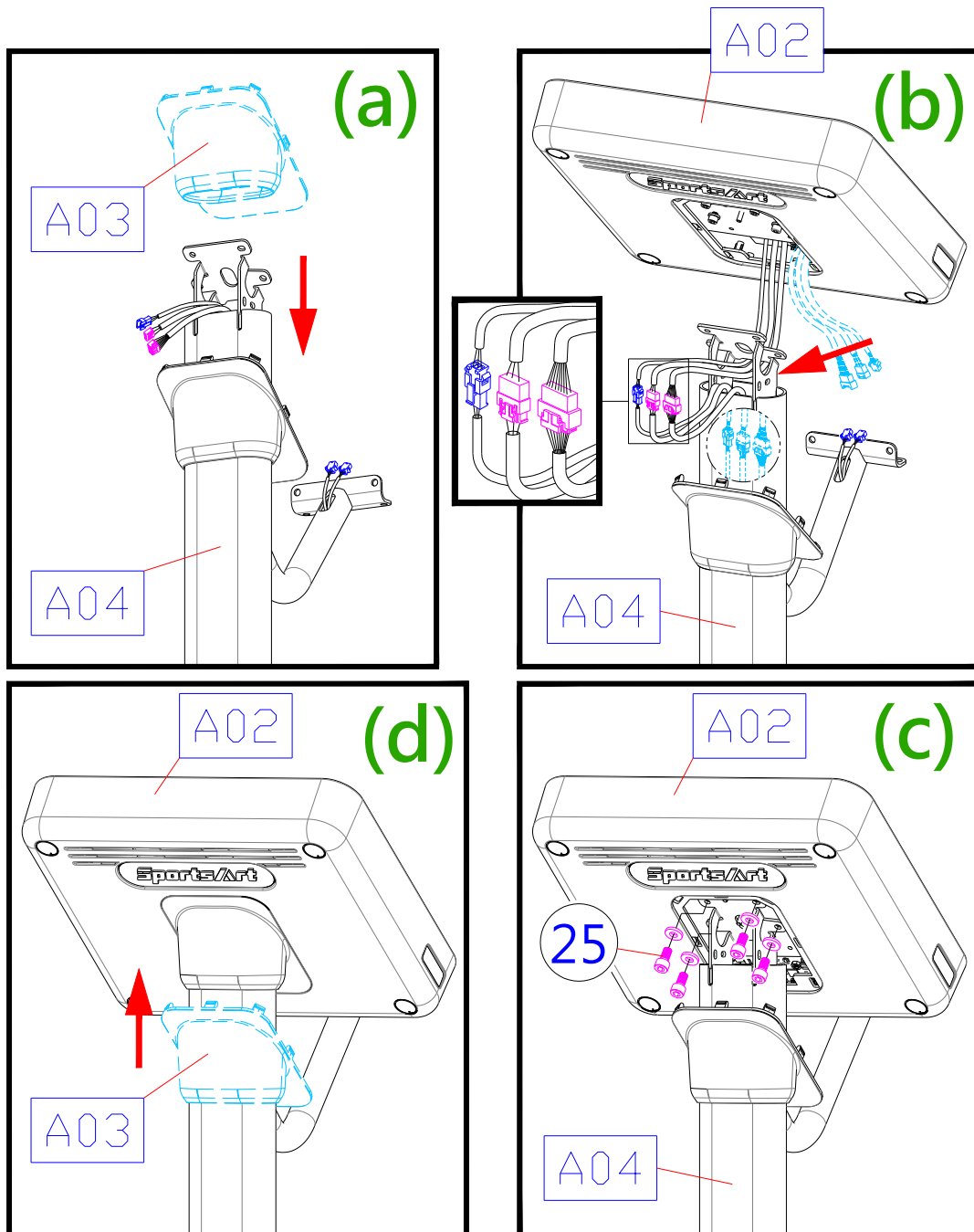

STEP 4 The Handlebar Installation

- (a). Secure the handlebar (A07) onto the console mast (A04) with the screws (26).
- (b). After connect the data cable of the handlebar (A07) to that in the console mast (A04), and then put them into the opening.
- (c). Install the upper and lower handlebar covers (A08) to the handlebar and secure them with the screws (20).

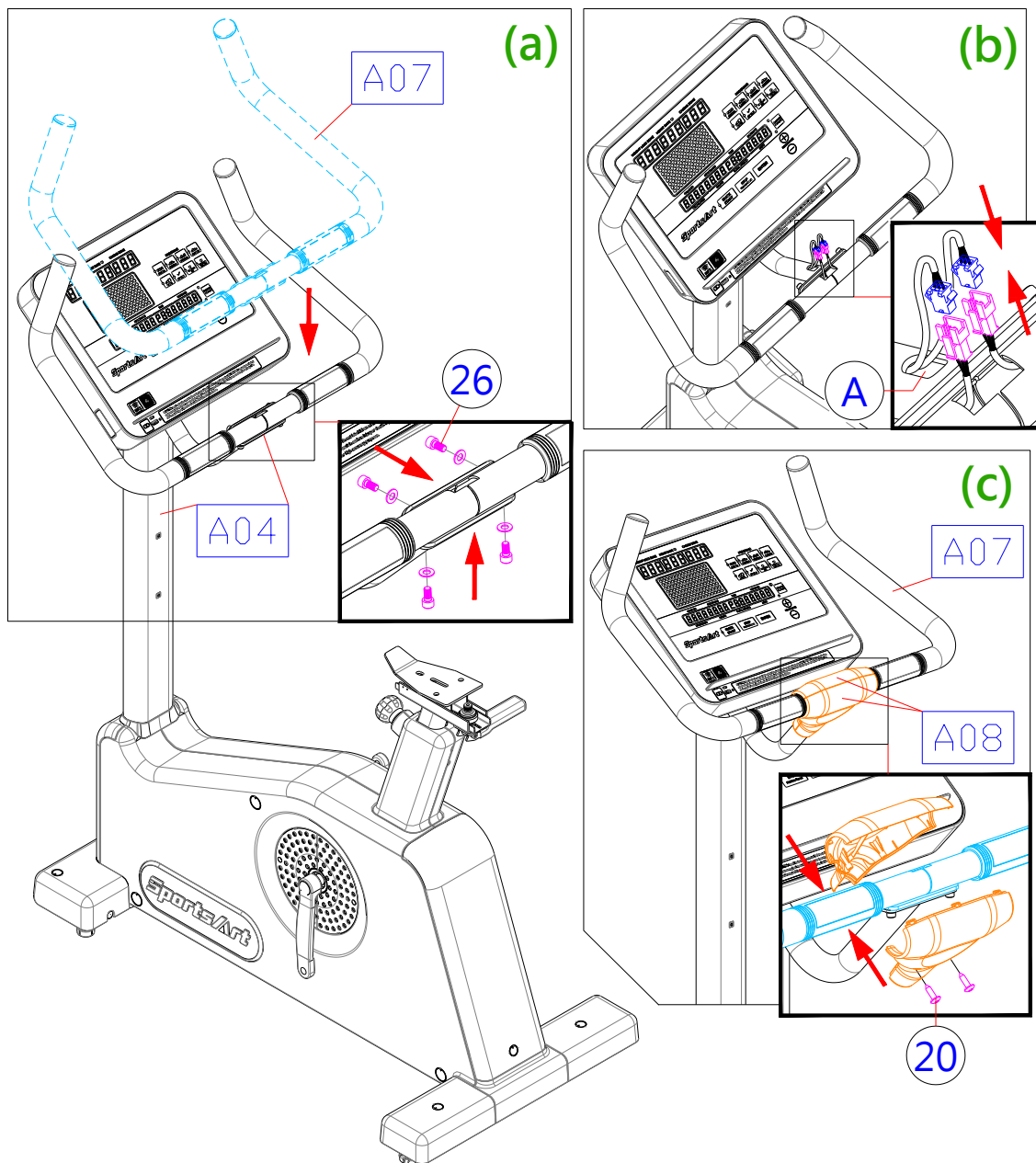

STEP 5 The Pedal Installation

Use the tool enclosed with the product to secure the left/right pedals (A10L/R) to the crank on the mainframe, please note that pedal spindle threads are different from left side and right side. DO NOT install in reverse. The tool should not be too short, otherwise, it can damage the pedals. (please use the attached wrench size in 13*15).

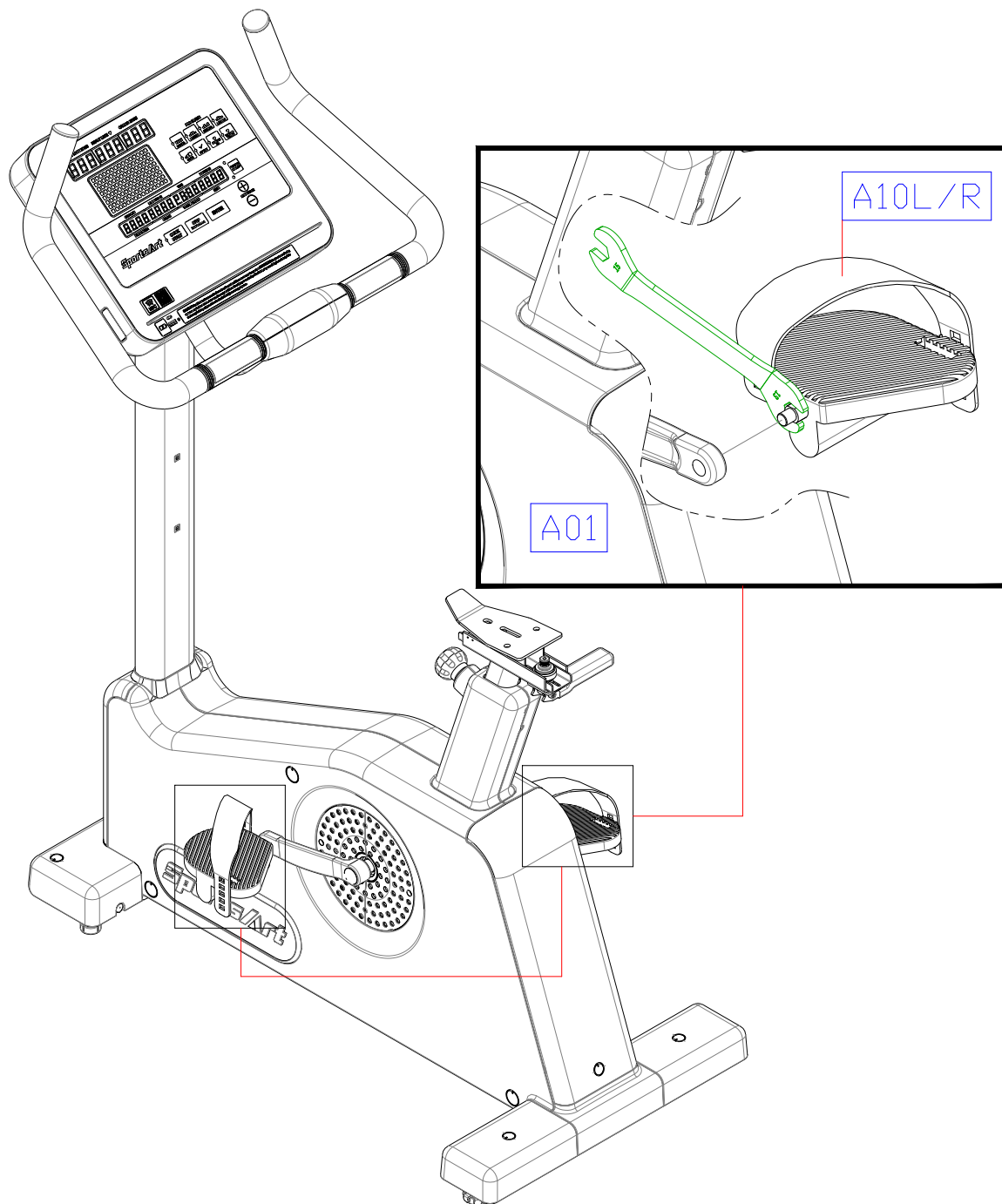

STEP 6 The Seat Installation

As shown below, align the seat (A09) with the holes and insert it. Then tighten the nuts (27) to secure the seat (A09).

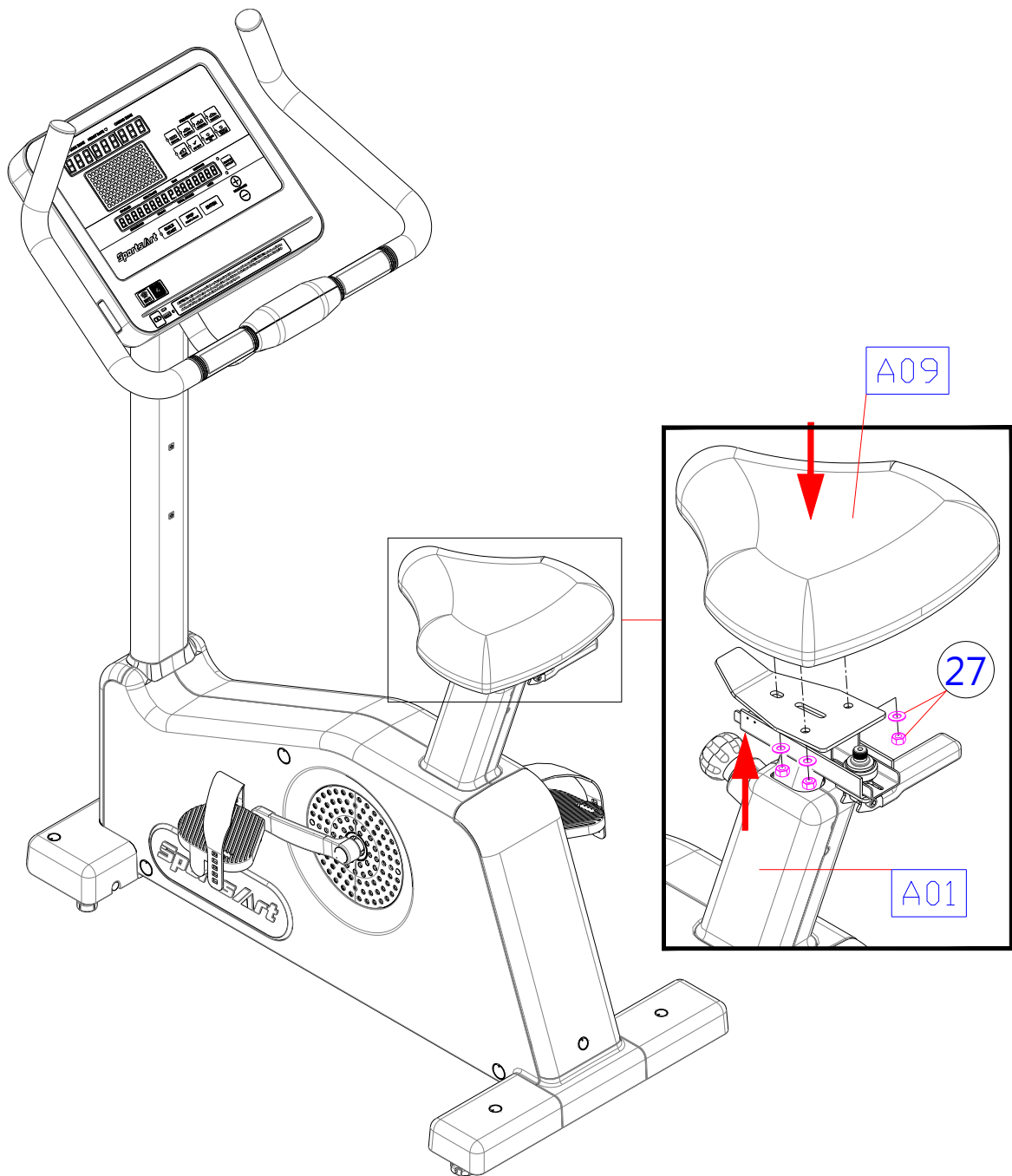

STEP 7 Storage tray Installation

※.Before assembling, confirm whether there is a screw socket (17).

※.Use these screws (18) to secure the storage tray (A05) onto the console mast (A04).

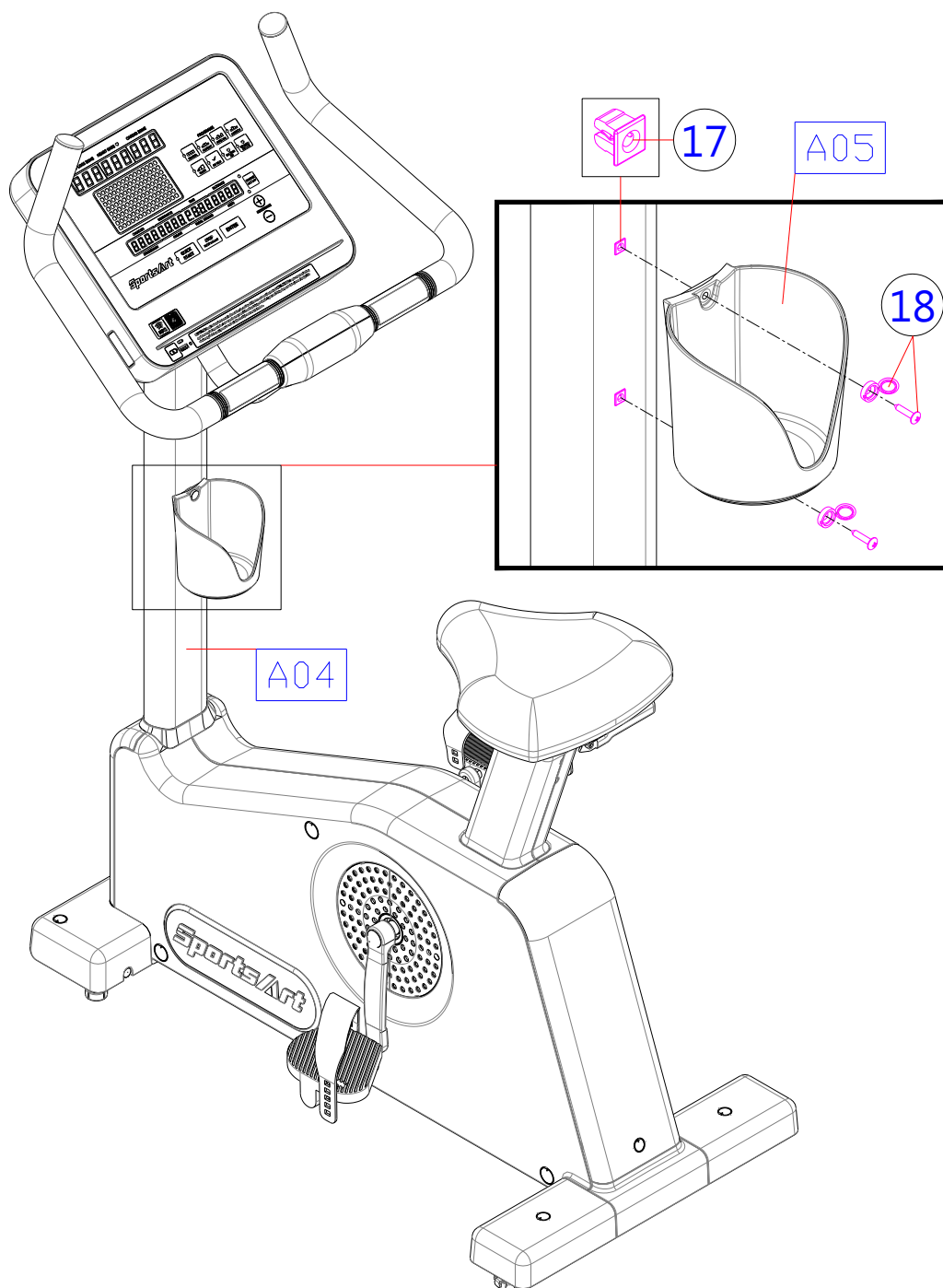

STEP 8 Move the Bike into Place for Use

Stand in front of the bike, with one foot against the front wheel. Tilt the bike by the handlebars until the wheels touch the ground, with it can be moved to the desired position.

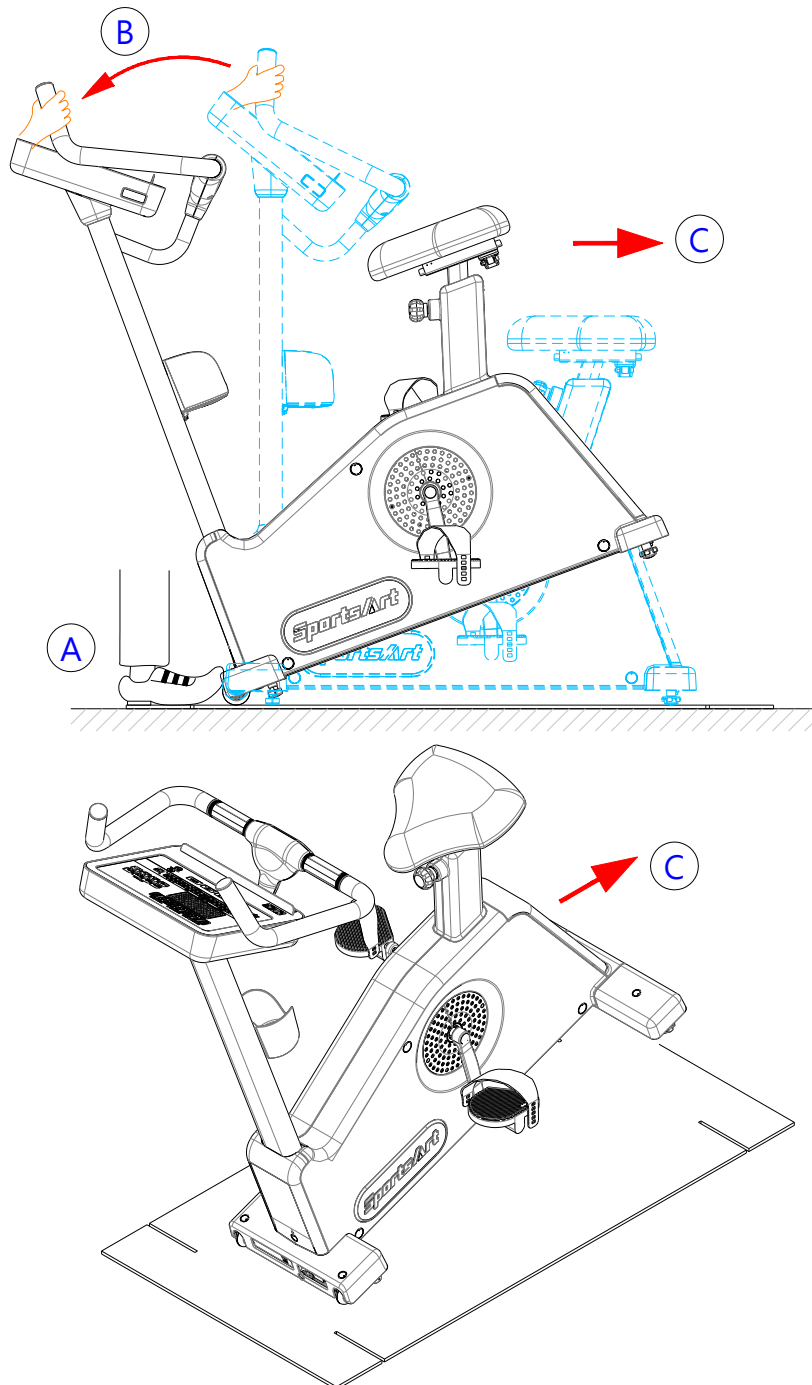

STEP 9 Level the Bike

Press downward on the rear part of the bike as shown. Inspect whether the bike rests flat on the floor. If the bike wobbles, adjust bike levelers as follows:

- (a). Loosen the leveler knob.
- (b). Rotate the leveler foot downward until touching the floor.
- (c). Rotate the leveler knob upward against the frame of the product to secure this position.

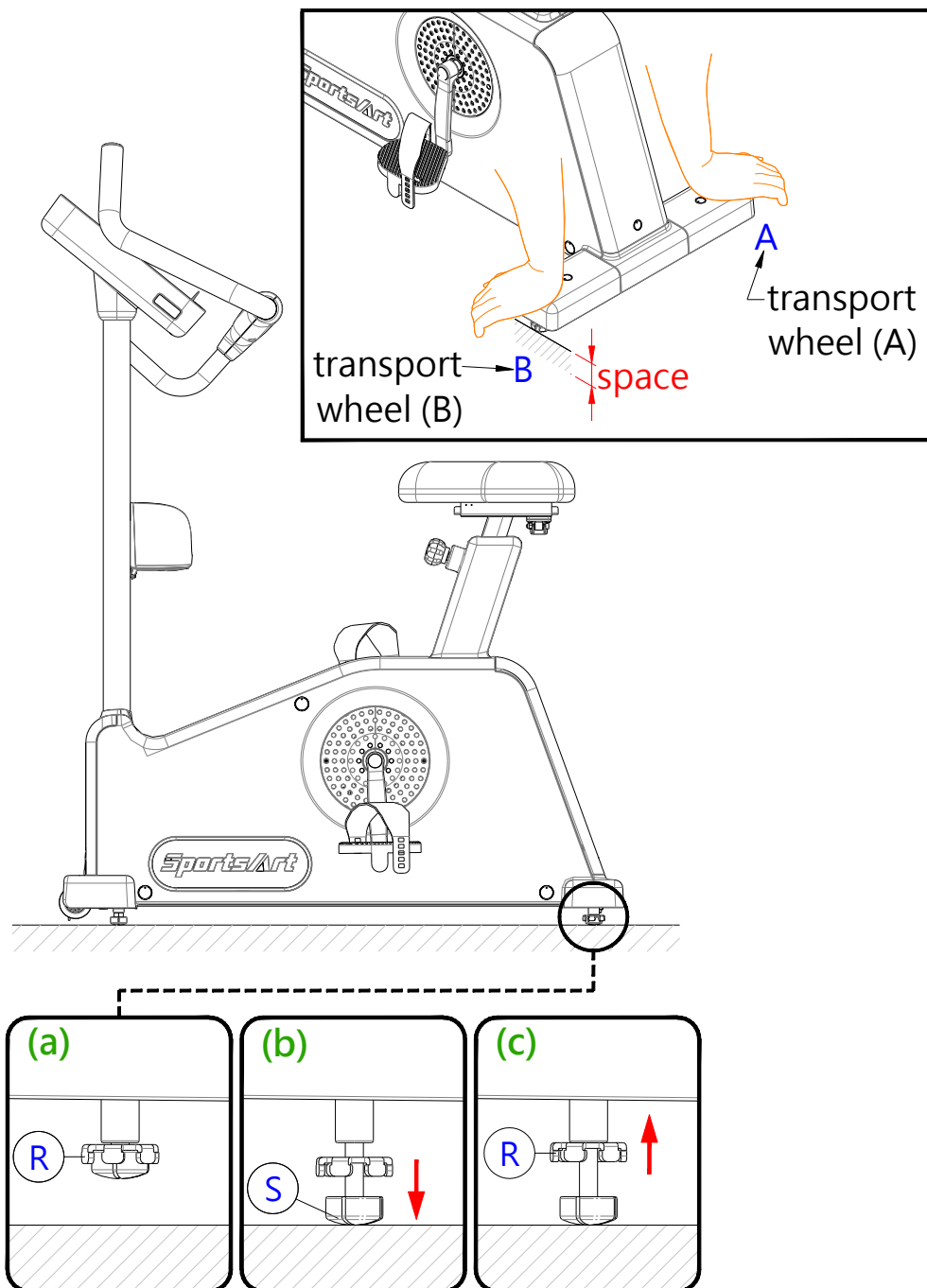

STEP 10 Ground Wire Installation Instructions

- ※.In order to avoid electric shock and current leaking, an additional ground wire is provided enclosed with the product.
 - ※.For safety reasons, put the ground wire into the opening as shown. Be sure to connect the ground wire to the equipment.
 - ※.Assembly Instructions: Secure one end of the ground wire to the base frame with screws (as shown in the following figure) while the other end connected to the earth ground.
- The figure below is for reference purposes only.

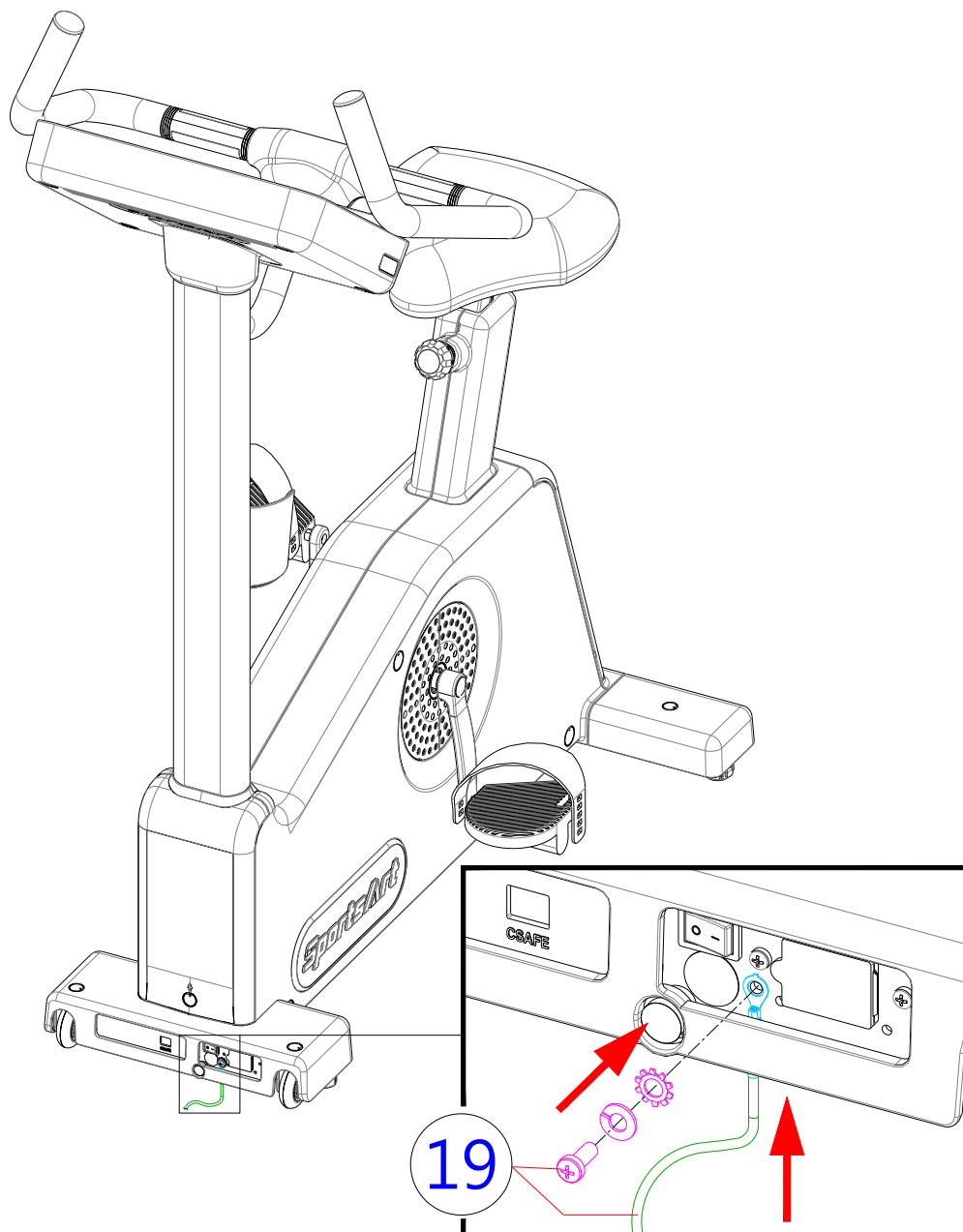

6. UNDERSTAND LED DISPLAY PANEL

DISPLAY Overview

In this chapter, you will learn how to use and set up the console of your product. Please read the entire manual prior to using the product to get the best exercise efficiency and enjoy your workout.

DISPLAY Console Panel



No.	Description	No.	Description
1	Exercise Feedback Window	6	PROGRAMS
2	QUICK START key	7	CHANGE DISPLAY key
3	STOP/RESET key	8	RESISTANCE +/- key
4	QR Code · NFC tag	9	ENTER key
5	USB port		



No.	Description	No.	Description
1	Exercise Feedback Window	6	HUMAN WATTS Window
2	QUICK START key	7	PROGRAMS
3	STOP/RESET key	8	CHANGE DISPLAY key
4	QR Code · NFC tag	9	RESISTANCE +/- key
5	USB port	10	ENTER key

DISPLAY Windows Display

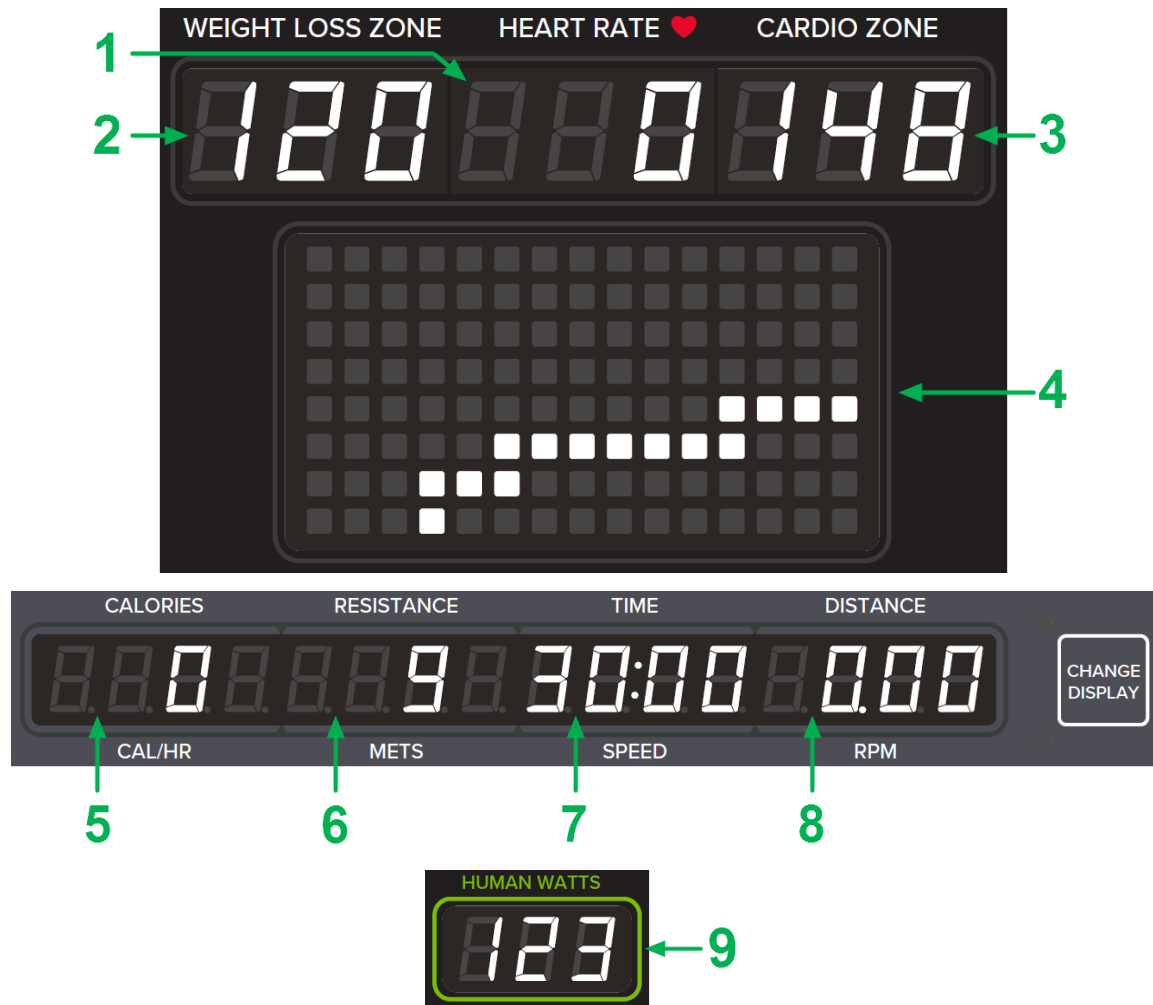









No.	Description
1	Display the data of your heart rate value. (Displayed when BOTH HANDS hold on the sensor.)
2	Shows WT LOSS 65%.
3	Shows CARDIO 80%
4	Display the messages or the illustration.
5	CALORIES : Display the total calories of the workout or the remaining calories to exercise. CAL/HR : Display the Calories burned per hour.
6	RESISTANCE : Display your resistance level. METS : Displays the current MET.
7	TIME : Display the total time of the workout or the remaining time to exercise.

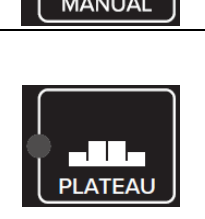

	SPEED : Displays the actual speed.
8	DISTANCE : Display the total distance of the workout or the remaining distance to exercise. RPM : Display the pedal revolutions per minute.
9	HUMAN WATTS : Display the current HUMAN WATT amount.

DISPLAY Specifications

Parameter	Spec.
SPEED	Above 0.1 KPH(MPH)
RPM	5 – 150
RESISTANCE	1 – 15
HEART RATE	35 – 255 bpm
TIME	0:00 – 99:59 ; 100 – 9999 minute
DISTANCE	0.00 – 9999 Mile/Km (display maximum of 2 decimal places)
CALORIES	0 – 9999 K-CAL
CAL/HR	0 – 9999 K-CAL
METS	0.0 – 99.9 K-CAL/Kg/Hour
PROGRAM	MANUAL, PLATEAU, INTERVAL, RANDOM, FAT BURN, FIT TEST, CUSTOM HR, WT LOSS, CARDIO

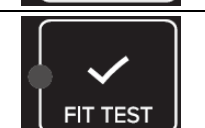
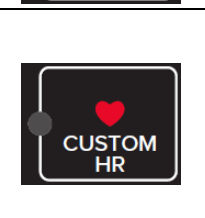
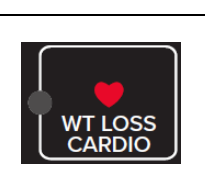
DISPLAY Button Function

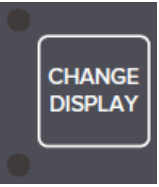
Illustration	Description
	Skip the user input, program selection, and start training instantly.
	Press to stop the workout program Hold down to go back to start screen and reset it to factory settings.
	After the parameter settings are complete, press the key to confirm your selection.
	Press this key to enter Manual mode. The notification LED will stay lit.
	This program is to simulate a workout on a plateau. The first and the last segment accounts for 20% of the workout respectively, and the middle segment accounts for 60% of the workout. The notification LED will stay lit.
	Press this key to select one of three interval programs: 1:1, 1:2, 2:2. Numbers represent minutes. The notification LED will stay lit.
	Press this key to select one of an almost endless number of randomly generated workout programs. Each key press, the console will randomly generate a different program. The notification LED will stay lit.
	Changes the difficulty from 1 to 20. The default value is 1 The notification LED will stay lit.
	Press this key to enter fitness test mode. The notification LED will stay lit.
	Press this key to enter CUSTOM HR mode. His heart rate control program allows you to set your own target heart rate. The notification LED will stay lit.
	Press this key to select <WT LOSS> or <CARDIO>. *<WT LOSS> uses the following formula to evaluate target heart rate: $(220 - \text{AGE}) \times 0.65$.

	<p>*<CARDIO> uses the following formula to evaluate target heart rate: $(220-AGE)\times 0.8$.</p> <p>The notification LED will stay lit.</p>
	<p>There are two rows of exercise feedback, only one of which is visible at a time.</p>
	<p>Press this key to change resistance level. Resistance changes by one level each time the key is pressed.</p> <p>Hold down the key to change resistance quickly.</p>

7. OPERATE THE PRODUCT

OPERATION Safe Operating Area

Safety clearance required as shown below. Do not allow people to be near this area when operating.

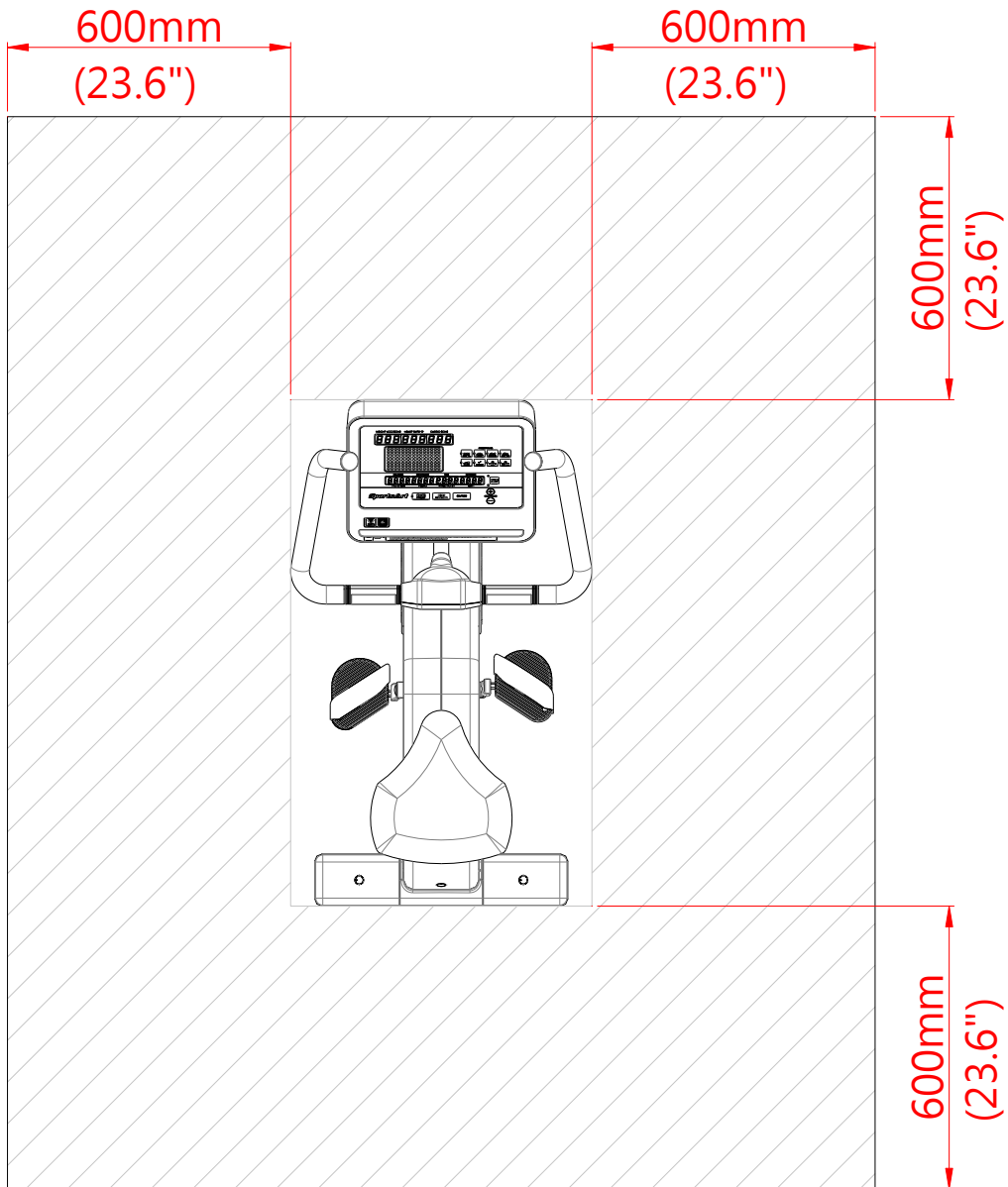

OPERATION The Seat Adjustment (Cont.)

- (a). Press the fore/aft adjustment lever downward to release the seat.
- (b) Use your hand to move the seat fore or aft as desired.
- (c) Lift the fore/aft adjustment lever upward to secure this position

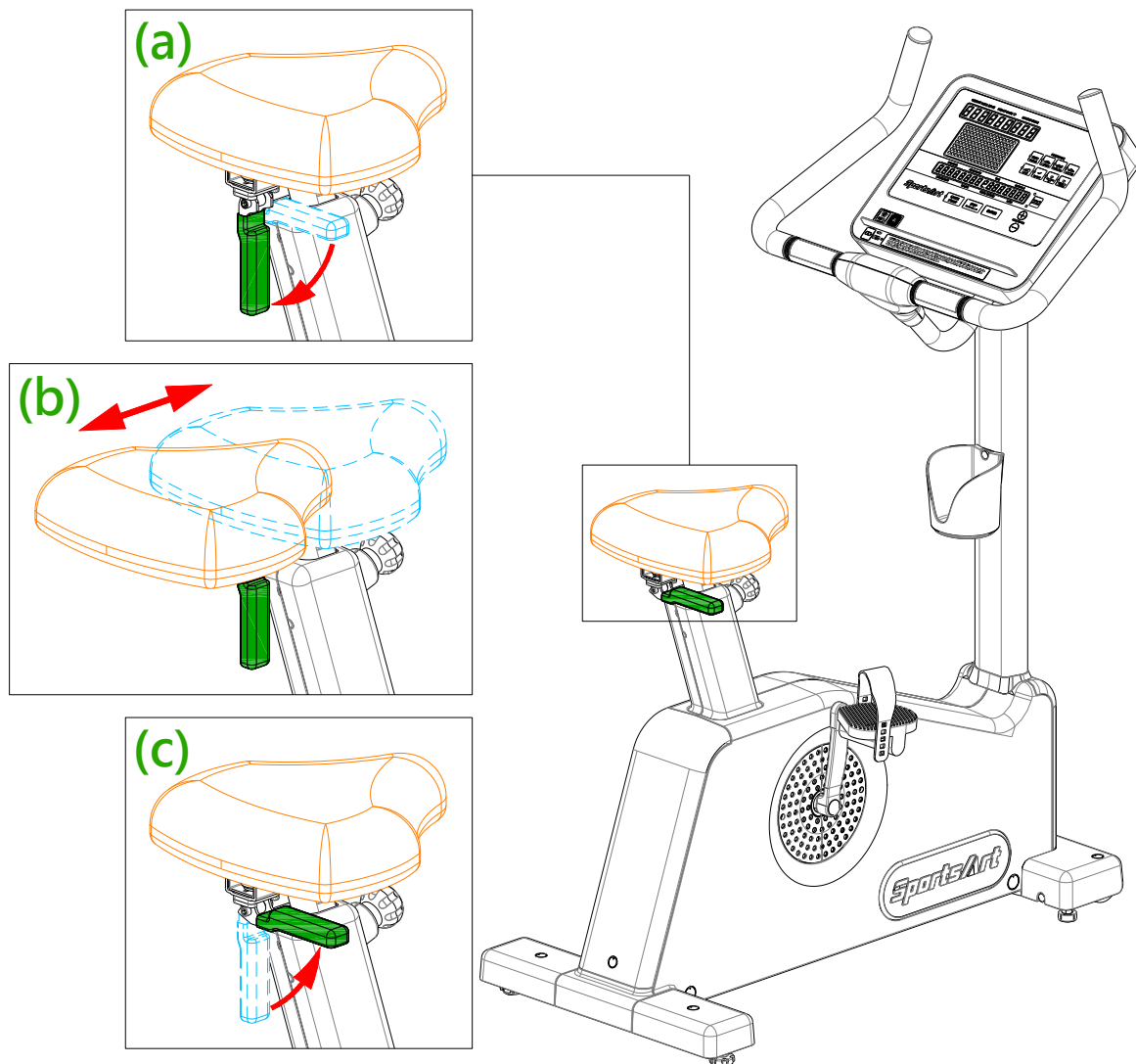

OPERATION Get On And Get Off The Bike

Always be cautious when getting on or getting off the bike. Waiting until the pedals have come to a complete stop.

Get on the equipment: Sit on the bike and then hold the handles while putting both feet on the pedals as shown below.

Get off the equipment: Slow down and then remove both feet from the pedals.

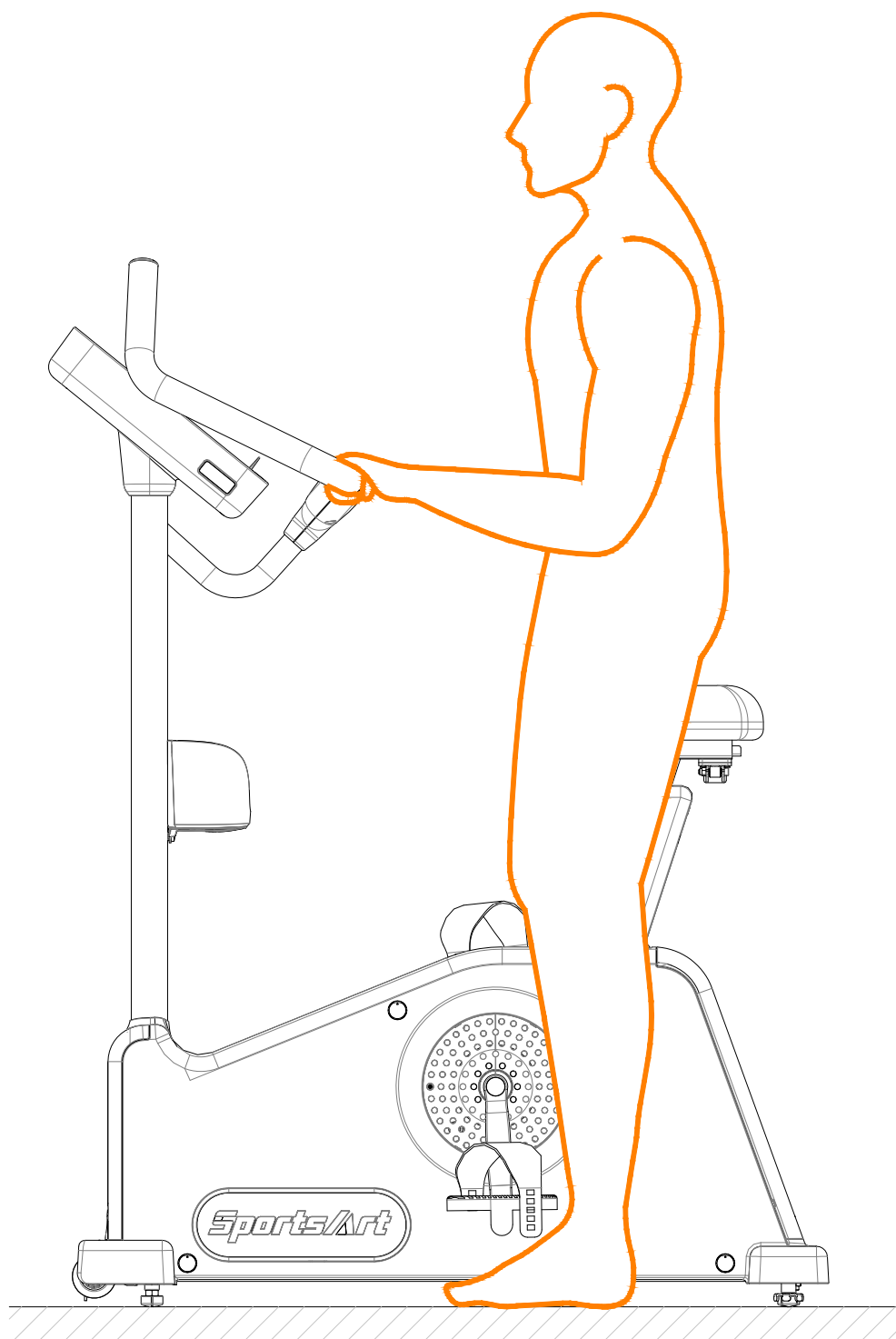

OPERATION Exercising Instructions

(a). A good riding posture is illustrated below.

(b). Always follow the directions for use and safety instructions given by the manufacturer.

Over exercise or improper workout position may result in serious injury

(c). Hold onto the handlebar while getting off the bike from left/right side.

(d). This product is intended to build your leg and cardiovascular strength

※. Please exercise within the range of your skill and training. DO NOT work to exhaustion.

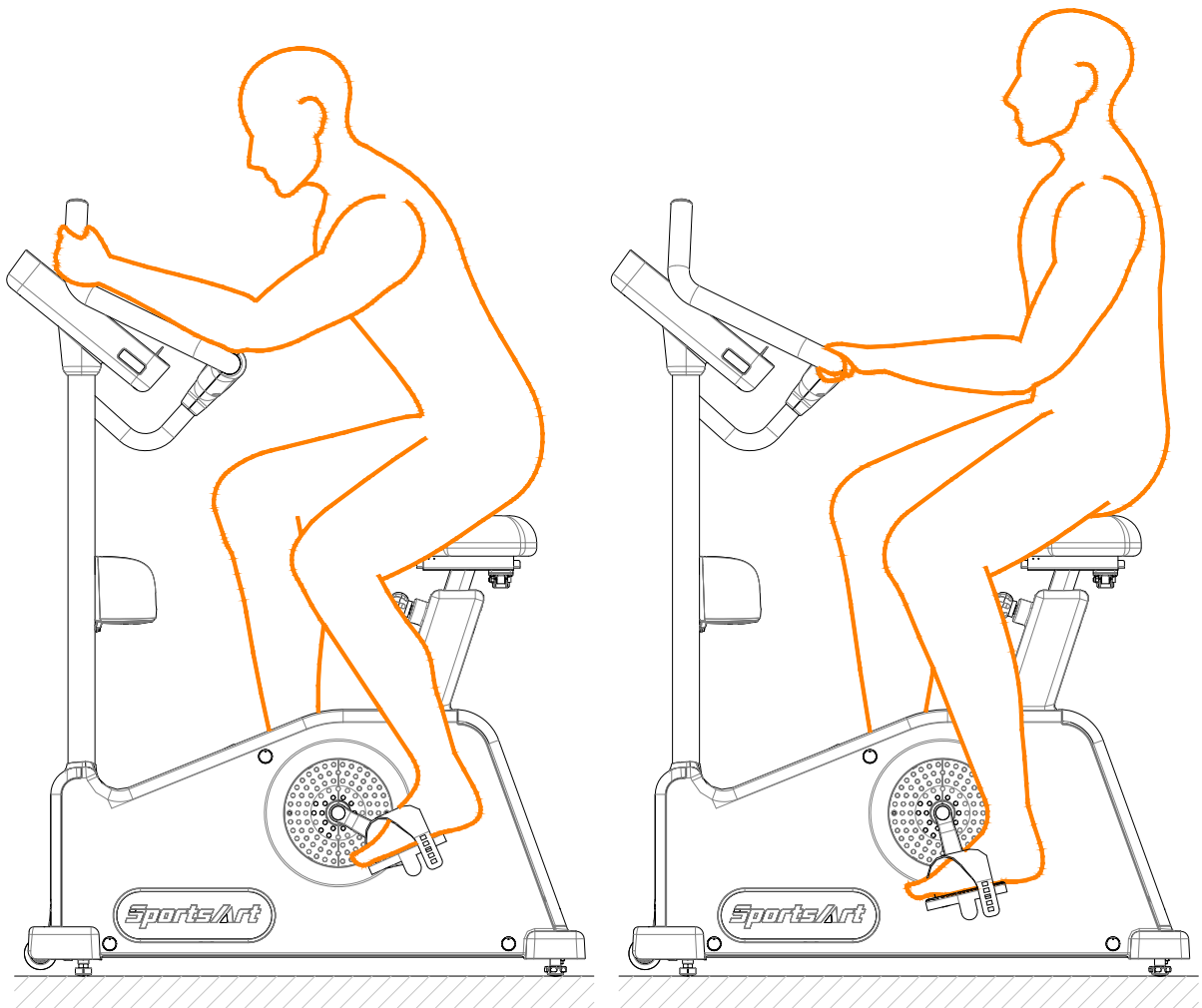

8. PANEL THE PRODUCT

OPERATION Start Screen

Step on the pedal to start the machine. After starting, you will hear the BEEP sound and see the start screen. "SPORTSART-C565".

OPERATION Quick Start Mode

QUICK START mode is preset based on user 35 years old and weighs 75 kilograms (165 pounds). The program is preset at manual, and the resistance is preset at 1. You can press the QUICK START key to start exercise directly or reset the parameters to your preference.

OPERATION User Setting Procedure

The product measures your calories burned (based on weight), target heart rate (based on age), total time, and total distance based on your personal information that you have entered.

1.PROGRAM Select

Press <PROGRAM> key and then press <ENTER> key will take you to the "SELECT GOAL" screen. For details about setting workout goals, please refer to "WORKOUT GOAL Setting".

2.WORKOUT GOAL Setting

If you select a program key, then "SELECT GOAL" & then "TIME" will appear on the exercise feedback window. There are three types of workout goals: TIME, DISTANCE, and CALORIE. Press < RESISTANCE +/-> keys to select the desired goal and <ENTER> key to confirm. Once the program is started, resistance setting can be modified at any time.

(a).Setting a TIME workout goal

Select <TIME> as your workout goal, then proceed to time settings. The range is 5 - 300 minutes with the default of 30 minutes. If TIME set is below the adjustment range due to certain program requirement, the time limit will be assigned a lower value accordingly.

Press <RESISTANCE +/-> key to adjust the time.

Press <ENTER> key to confirm the time settings.

(b).Setting a DISTANCE workout goal

Select <DISTANCE> as your workout goal, then proceed to calories settings. The range is 0.1 - 99.9 miles/kilometers with the default of 2 miles/3 kilometers. If there's a time limit

in the workout program selected, the DISTANCE workout goal will be disabled.

Press <RESISTANCE +/-> key to adjust the calories.

Press <ENTER> key to confirm the calories settings.

(c).Setting a CALORIES workout goal

Select <CALORIES> as your workout goal, then proceed to calories settings. The range is 100 - 9999 kCal with the default of 100 kCal. If there's a time limit in the workout program selected, the CALORIES workout goal will be disabled.

Press <RESISTANCE +/-> key to adjust the calories.

Press <ENTER> key to confirm the calories settings.

3.AGE and WEIGHT

Having finished the GOAL settings, proceed to AGE and WEIGHT setting. Refer to the following instructions for details.

(a).AGE Setting

The range is 10 - 99 years old with the default of 35 years old.

Press <RESISTANCE +/-> key to adjust the age.

Press <ENTER> key to confirm the age setting and proceed to weight settings.

(b).WEIGHT Setting

The range is 50 lb (20 kg) - 400 lb (180 kg) with the default of 165 lb /75 kg.

Press <RESISTANCE +/-> key to adjust the weight.

Press <ENTER> key to confirm the weight setting and to start exercise.

OPERATION Workout Programs

You can choose the desired program from the PROGRAM menu. The following information provides details about the programs.

MANUAL:

The general mode. Users can set their desired workout program. And the resistance can be adjusted according to your own preference.

PLATEAU:

This program is to simulate to workout on the plateau, the change in resistance is shown in the picture below. The first and the last segment each accounts for 20% of the workout. The middle segment accounts for 60% of the workout.

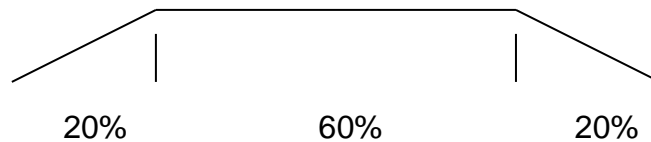

INTERVAL:

This program includes alternating periods of high-intensity aerobic exercise with low-intensity exercise.

- 1.The program is a two-stage exercise (REST/WORK) and each has different parameters of the time and the resistance. According to the time ratio, there are three options: 1:1,1:2 and 2:2.

(For example: “ 1 : 2”means one minute for resting and 2 minutes for workout.)

- 2.The program changes between INTERVAL 1:1/ INTERVAL 1:2/ INTERVAL 2:2 each time the <INTERVAL>key is pressed. Press <ENTER> key to confirm your selection.
- 3.Since it is a two-stage training program. You can change the “REST” parameters to your preferred setting and the machine will remember those settings. The same options apply to the “WORK” parameters. The unit will operate according to the last setting for the future REST and WORKOUT segments.

RANDOM:

The graphic pattern in RANDOM PROGRAM is generated randomly, and the illustration shows differently each time

- 1.Press the <RANDOM> key to select the desired graphic pattern.
- 2.During exercise, you can press the <RANDOM> key to change the graphic pattern.

FAT BURN:

The FAT BURN mode provides the exercise mode to burn fat. According to the difficulty, there are 20 levels to choose from.

- 1.You need to set the level of the STAGE prior to get started, the range is 1 - 20, and the default is STAGE 5.

(1).The window will display the illustration of the 20 levels in different.

(2).Press <RESISTANCE +/-> key to set STAGE.

(3).Press <ENTER> key to confirm and enter PROGRAM settings.

- 2.Press <RESISTANCE +/-> key to change the level of STAGE during exercise.

FIT TEST:

The FIT TEST program is designed for physical fitness assessments. The program is set with a time limit; therefore it is not restricted by the program time limit setting at the engineering mode.

1. Select this mode, then simply enter your age, weight, and gender before you start your workout.
2. Start fitness testing after the words "STARTING TEST" pop up.
3. This program has four parts, and each part will take 3 minutes to complete. The resistance in each part is variable and depends on your current speed.
4. The recommended RPM is displayed as a dot at the top of the console, and your current speed is displayed as a wavy line at the bottom of the console. Try to match your current speed with the target speed.
5. The best RPM range during test is 50 ± 5 RPM.
6. The table below shows how the test process works.

Heart rate Stage	< 80BPM	80-89BPM	90-100BPM	> 100BPM
1	25W	25W	25W	25W
2	125W (750kgm/min)	100W (600kgm/min)	75W (450kgm/min)	50W (300kgm/min)
3	150W (900kgm/min)	125W (750kgm/min)	100W (600kgm/min)	75W (450kgm/min)
4	175W (1050kgm/min)	150W (900kgm/min)	125W (750kgm/min)	100W (600kgm/min)
NOTE	If the heart rate is not in the range of $((220 - \text{age}) * 0.85 - 10)$, proceed to stage 5, 6...and so on. Every stage will make the next take more load (+25W).			

(1). Each exercise stage lasts for 3 minutes.

(2). Tips for each exercise stage:

Stage 1: the default watt load is 25W, and the watt load for next stage depends on the heart rate measured at last 15 sec. of stage 1.

For example, if the heart rate measured at last 15 sec. of stage 1 is 92bpm, then the watt load for stage 2 is 75W, 100W for stage 3, 125W for stage 4...and so on.

Stage 2,3,4: Actual heart rate will be measured during the second and third minute of each stage. When the stage ends, the difference of these heart rates will be

calculated. (Third minute heart rate minus second minute heart rate)

(a).If $((220-\text{age})\times 0.85)-10 < \text{heart rate} \leq 5$ bpm, the exercise ends.

(b).If heart rate $< ((220-\text{age})\times 0.85)-10$, and is less than 5bpm, the exercise continues to the next stage.

(c).If heart rate > 5 bpm, the exercise stage extends 1 min. and the heart rate will be measured again. Use the above formula and the calculated value to determine whether this exercise stage continues or ends.

Additional Stages: Results are determined according to a, b and c conditions of Stage 2, 3 and 4.

(3).Every time you enter a new exercise stage, the unit automatically adjusts your resistance level based on your RPM to match the corresponding watt load. Take stage 2 for example, if the watt load is 100w and the RPM is 51, the bike will automatically adjust to level 7.

7.Scoring:

A score is calculated based on user's VO2max, see the following table for details.

$$SM1 = (\text{Watt/kg in stage 2} \times 10.8) + 3.5 + 3.5$$

$$SM2 = (\text{Watt/kg in final stage} \times 10.8) + 3.5 + 3.5$$

$$HR1 = (\text{HR in the second to last min. of stage 2} + \text{HR in the last min. of stage 2}) / 2$$

$$HR2 = (\text{HR in the second to last min. of final stage} + \text{HR in the last min. of final stage}) / 2$$

$$b = (SM2 - SM1) / (HR2 - HR1) \quad \text{*note : "b" is for slope}$$

$$HR_{\text{max}} = (220 - \text{age})$$

$$VO2_{\text{MAX}} = SM2 + (b \times (HR_{\text{max}} - HR2))$$

Percentile Values For Maximal Aerobic Power($\text{ml.kg}^{-1}.\text{min}^{-1}$)--Men					
Percentile	Age				
	20-29	30-39	40-49	50-59	60+
90	51.4	50.4	48.2	45.3	42.5
80	48.2	46.8	44.1	41.0	38.1
70	46.8	44.6	41.8	38.5	35.3
60	44.2	42.4	39.9	36.7	33.6
50	42.5	41.0	38.1	35.2	31.8
40	41.0	38.9	36.7	33.8	30.2
30	39.5	37.4	35.1	32.3	28.7

20	37.1	35.4	33.0	30.2	26.5
10	34.5	32.5	30.9	28.0	23.1

Percentile Values For Maximal Aerobic Power(ml.kg ⁻¹ .min ⁻¹)--Women					
Percentile	Age				
	20-29	30-39	40-49	50-59	60+
90	44.2	41.0	39.5	35.2	35.2
80	41.0	38.6	36.3	32.3	31.2
70	38.1	36.7	33.8	30.9	29.4
60	36.7	34.6	32.3	29.4	27.2
50	35.2	33.8	30.9	28.2	25.8
40	33.8	32.3	29.5	26.9	24.5
30	32.3	30.5	28.3	25.5	23.8
20	30.6	28.7	26.5	24.3	22.8
10	28.4	26.5	25.1	22.3	20.8

You will have a zero score if you haven't completed more than 3 stages in the process.

The following is an example of calculating VO2MAX for a 40-year-old, 62kg male:

(1).The heart rate $\geq ((220-\text{age})\times 0.85)-10$ in the last min. of stage 3. The

exercise ends. The watt load and heart rate for each stage are presented in the following table.

階段	負載(WATT)	時間(分鐘)	HR(bpm)
1	25W	0-1	86
		1-2	90
		2-3	92
2	75W	3-4	120
		4-5	135
		5-6	139
3	100W	6-7	151
		7-8	159
		8-9	163

(2).Calculating VO₂MAX and scoring:

$$SM1 = (75/62 \times 10.8) + 3.5 + 3.5 = 20.06 \text{ ml} \cdot \text{kg}^{-1} \cdot \text{min}^{-1}$$

$$SM2 = (100/62 \times 10.8) + 3.5 + 3.5 = 24.42 \text{ ml} \cdot \text{kg}^{-1} \cdot \text{min}^{-1}$$

$$HR1 = (135 + 139) / 2 = 137 \text{ bmp}$$

$$HR2 = (159 + 163) / 2 = 161 \text{ bmp}$$

$$b = (24.42 - 20.06) / (161 - 137) = 0.182$$

$$HR_{\text{max}} = (220 - 20) = 200$$

$$VO_2\text{MAX} = 24.42 + (0.18 \times (200 - 161)) = 31.5 \text{ ml} \cdot \text{kg}^{-1} \cdot \text{min}^{-1}$$

We use the VO₂MAX table and find the corresponding score is 10.

8.End of exercise:

(1).Press the <STOP> key.

(2).Complete the entire cycle of the exercise process.

(3).Current heart rate > (220-AGE)×0.8, and lasting for 15 sec.

(4).No detectable heart rate for 30 sec.

(5).Heart rate < 45RPM, or heart rate > 55RPM, lasting for 15 sec.

9.When the program ends, the console shows “END OF FIT TEST” and the user’s score

“YOUR SCORE- XXX”, then enters COOL DOWN mode. Note: XXX represents user’s score, 0 to 90.

CUSTOM HR / WT LOSS / CARDIO:

These programs take control of speed and incline, keeping your heart rate within the target zone.

1.The target heart rate for each program:

(a).The user determines his/her target heart rate. The calculation does not take into account his/her age.

(b).WT LOSS:the target heart rate that is calculated by the formula (220-AGE) * 0.65.

(c).CARDIO: the target heart rate that is calculated by the formula(220-AGE) *0.80.

2.If CUSTOM HR is selected, the target heart rate will need to be set first. The range is 84 - 199bpm with default value of 120bpm.

(a).The display will show “TARGET HR - XXX”.

(b).Press <RESISTANCE +/-> keys to adjust the setting.

(c).Press <ENTER> key to confirm and start the program.

3.If you keep pedaling, a dot will appear on the parameter window (just below the heart pattern), which represents the target RPM. The line below represents the actual RPM.

Overlap between the dot and line indicates that you've reached the target speed.

4. Resistance will start at level 1, and the default is 50 RPM, your actual heartbeat is detected at all times.
5. If the actual RPM is 5 RPM less than target speed, lasting for more than 25 seconds, the words "SPEED UP" will pop up on the display.
6. During exercise, if the machine cannot read your heartbeat signal, it will display "NO HEART RATE READING , PLEASE CHECK TRANSMITTER" on your screen, and the resistance can only be adjusted manually.

OPERATION During Exercise

During exercise, you can switch to a different program using the same WORKOUT GOAL (TIME/DISTANCE/CALORIES) by pressing a different program key.

Some exercise programs are not interchangeable, and the words

"SWITCHING NOT ALLOWED" will pop up on the screen. See the following examples:

1. You cannot change to the FIT TEST program when you are using these programs: MANUAL, PLATEAU, INTERVAL, RANDOM, FAT BURN, CUSTOM HR, WT LOSS, and CARDIO.
2. You cannot change to the MANUAL, PLATEAU, INTERVAL, RANDOM, FAT BURN, CUSTOM HR, WT LOSS, and CARDIO programs when you are using the FIT TEST program.

OPERATION Cool Down

Once the goal (TIME, DISTANCE, and CALORIES) has been achieved, it will show the message "COOL DOWN" on your screen. The machine will enter a two-minute cool down period.

1. If the resistance level is higher than 5 when entering COOL DOWN mode, it will be automatically set to 5.
2. Press <STOP> key or countdown to 0:00 after entering a two-minute cool down period, it will display REVIEW SUMMARY.

OPERATION Stop Exercise

Press <STOP> key during exercise, all the exercise data will stop accumulating and keep the current value.

OPERATION Workout Summary

Press <STOP> key or after cool down, it will show the message “REVIEW SUMMARY” and your current workout status on the screen lasting for 15 seconds, then press <STOP> key once again to return to start screen.

OPERATION Idle Mode

The machine will turn into power saving mode when there is no stepping on the pedal or no button presses for 30 seconds, and the window will display “- - -” and continue to flash. To restart the machine, please step on the pedal or press any button to return to start screen.

OPERATION Auto Power Off Function

The machine will shut off automatically when there is no stepping on the pedal or no button presses for 2 minutes.

OPERATION Battery low voltage warning

The following symbol appear to indicate that the battery voltage is too low and needs to be charged.

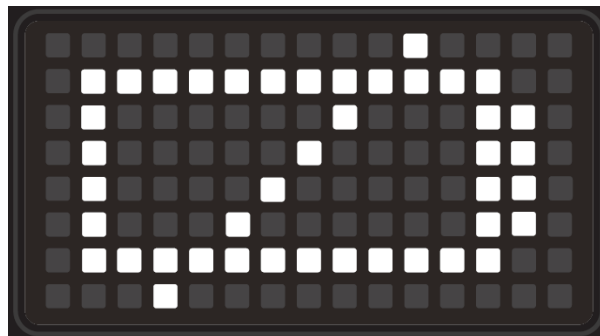

OPERATION Battery charging tips

The following symbol will appear when charging with the charger, indicating that the battery is being charged.

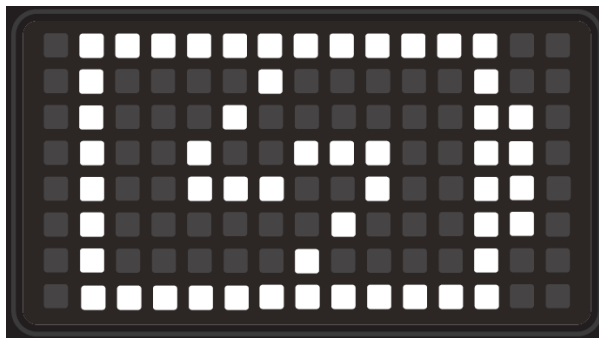

OPERATION User Parameter Setting

Hold the <CHANGE DISPLAY> key for 3 seconds to enter the user parameter setting procedures; press the <STOP> key at any time to return to the start screen.

Please refer to the following setting procedures:

1. Metric System / Imperial Units Setting

The window will display KM or MILE, press <RESISTANCE +/-> key to select the metric system or the imperial units, then press <ENTER> key to confirm your setting and go to the next step.

2. Display the Program Version

The window will show the version of each program, press <RESISTANCE +/-> key to view each program version, then press <ENTER> key and go to the next step.

Program Version Items:

(a).CTL xx-xxxx → The program version of the control board.

(b).SA WELL+ x.x.x → The program version of the SA WELL+ adapter.

(This function is only available if you purchase SA WELL+.)

3. Display the Mileage

The window will show the message of DIST- xxxxxx KM or DIST- xxxxxx MILE, press <ENTER> key and go to the next step.

4. Display the Total Time

The window will show the message of TIME- xxxxxx HOURS, press <ENTER> key and go to the next step.

5. Product Serial Number

The Window will show the message of "S/N- xxxxxxxx" (as shown below), press <ENTER> key and go to the next step.

6. Language Setting

The window will show the options of the countries, press <RESISTANCE +/-> key to select

your language, then press <ENTER> to confirm and go to the next step.

7.EUP Time Setting

(This function is only available if you purchase SA WELL+.)

The window will show the message of “EUP TIME– xx”, press <RESISTANCE +/-> key to set the sleep duration, then press <ENTER> to confirm and go to the next step.

※ The setting range is 5–20 minutes.

8.Time Limit Setting

The window will show the message of “LIMIT TIME– xx”, press <RESISTANCE +/-> key to set the time, then press <ENTER> key to confirm and go to the next step.

※ If the time limit is set less than 5 minutes, this function is deactivated. The setting range is 5-60 minutes or OFF.

9.Turn on/off the Buzzer

The window will show the message of “BUZZER– OFF” or “BUZZER– ON”, press <RESISTANCE +/-> key to turn on/off the buzzer, press <ENTER> key to confirm and go back to the next step.

10. Enable/ disable USB Charge Function

The window will show the message “USB CHARGE– OFF” or “USB CHARGE– ON”, press <RESISTANCE +/-> key to enable /disable USB charge function, then press <ENTER> key to confirm and go back to start screen.

※ If USB charge function is disabled, it is only available when you workout. If USB charge function is enabled, it is available both when you workout or not.

OPERATION Features

1.USB PORT

- (a).Provides up to 5V, 1A of power for charging
- (b).Let you update all required software drivers for the product.

2.CSAFE PORT

Compatible with CSAFE (Communications Specification for Fitness Equipment) Protocol.

3.QR code and NFC tag

Without SA WELL+ : Scanning the QR code and tapping the NFC tag will only display the SPORTSART website.

9. ABOUT HEART RATE DETECTION

Heart rate detection functions are selected at the time of purchase. Not every product has every type of heart rate detection. The following explains factors that influence the performance of two of the most common types of heart rate detection devices.

HEART RATE Telemetry

The words “telemetry heart rate” refer to the detection of heart rate via a device worn on the exerciser and transmitted over the air to a circuit board built into the product. Telemetry heart rate devices are commonly worn on the exerciser’s chest, where the pulse is strongest and relatively easy to detect.

The following explains conditions that affect the performance of the telemetry heart rate function in all products.

- The telemetry heart rate transmitter emits a wireless 5 kHz signal that is harmless to the human body. Keep a distance within 60cm between the heart rate receptor and the transmitter to achieve stable connection.
- If the battery is too low, the receiving distance may be shortened or there will be no reception.
- Secure the telemetry heart rate transmitter on your chest so that it stays in place without making you feel uncomfortable. Moisten the skin for better contact.
- Because the telemetry heart rate signal varies in strength from 20 Hz to 20 KHz, environmental interference can block signal reception. Physical vibration and electronic devices, including stereos, TVs, and even fluorescent lights, can interfere with signal reception. For best results, install the product in an area free from such interference.
- Space the product apart by at least 39 inches (100 cm) to avoid having the heart rate value from one exerciser appear on a neighboring product.

HEART RATE Contact

The words “contact heart rate” refer to the detection of the heart rate via sensors on the product. By holding the sensors, the exerciser can view his or her heart rate on the product display. Like telemetry heart rate, contact heart rate can be influenced by several factors.

The following list includes some of these factors.

- A weak pulse makes it difficult to detect heart rate.
- Low systolic blood pressure makes it difficult to detect heart rate.
- Dry, course palms impede heart rate detection. For best results, moisten your palms. But do not apply hand lotion immediately prior to your workout, because hand lotion can gum up the contact pads.

Heart rate devices built into this product are not medical devices. Heart rate values are for reference only. Do not use them for medical diagnostic or treatment work.

CAUTION: Heart rate detection and transmission devices have been known to interfere with the operation of pacemakers, possibly endangering human life. If you have a pacemaker, exercise under your doctor’s supervision; take a test to ensure your safety during the simultaneous use of the pacemaker and heart rate detection devices. The use of such devices must be undertaken at your own risk.

Note that in dry areas in particular, static electricity can interfere with unit operation and shock people. To discharge static electricity from your body, touch something else before touching metal on the product.

10. GUIDELINES FOR EXERCISE

HOW HARD SHOULD I EXERCISE?

Studies show that to benefit from aerobic exercise, people need to maintain a certain heart rate during their workouts. Your heart rate training zone depends on your age and fitness level.

The darkened area in the chart to the right represents the recommended heart rate training zone for people of various ages. It was calculated by taking 220 minus age in years, multiplied by 65% and 80%. The area between those values is the heart rate training zone.

CAUTION: Heart rate training zones are generalizations and may not suit every person.

Always check with your physician to understand what heart rate goal would be appropriate for you.

HOW LONG SHOULD I EXERCISE?

The duration of your workout must depend on your fitness level. In general, it is recommended that you maintain a heart rate within your training zone for at least 15 to 20 minutes to experience the benefits of aerobic exercise.

Beginners should always start out slowly and gradually increase the duration and intensity of their workouts. As your fitness level improves, you will be able to maintain a heart rate within the training zone for longer periods of time.

When you begin your workout, use the first several minutes to warm up. Then slowly increase the intensity of your workout to bring your heart rate into your training zone. At the end of your workout, gradually decrease your workload. Then exercise lightly to cool down.

HOW OFTEN SHOULD I EXERCISE?

Research indicates that to achieve the greatest benefit, people should exercise three to five times per week. It is important to allow sufficient time, at least 24 hours, for your body to recover after exercise.

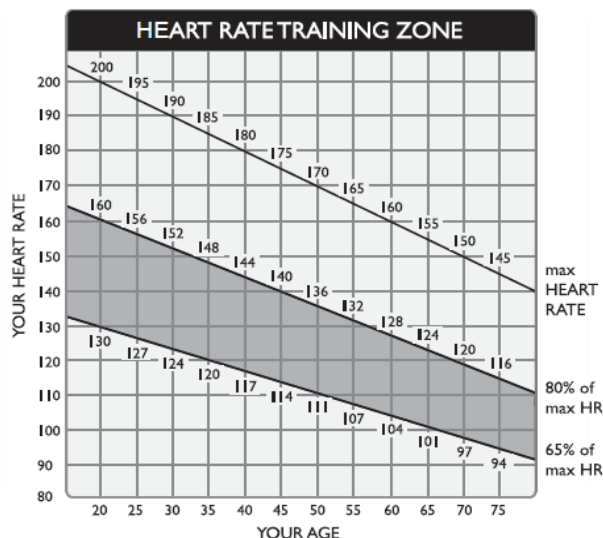

11. MAINTENANCE

MAINTENANCE Safety Precautions

- Please follow standard safety precautions when servicing on this product.
- Do NOT use a damp towel to clean the product but do perform the following maintenances.
- Do NOT use cleaners with alcohol, ammonia, or other damaging chemicals. The use of such chemicals can damage the product and void the warranty. Never spray or pour any liquid directly onto the product. Doing so can damage electronic components and void the warranty.
- Use a clean, lint-free towel, dampened with a mixture of Simple Green® all-purpose cleaner, to thoroughly clean the handlebar and the console.
- This product has moving parts that can be hazardous. Exercise caution when maintaining, operating, or moving this product.
- Do not use accessories or parts that are not specifically recommended by the manufacturer (SportsArt) . Such parts might cause injuries or cause the unit to fail and void the warranty. We will not be responsible for any safety issue that arises due to the misuse of accessories or parts. At the same time, we will terminate the warranty terms of this equipment.
- Maintenance and repair must be performed by trained service personnel only. Improper maintenance would not only damage the machine, but also may present a danger to the exerciser.
- Keep this product out of use until maintenance is completed.
- The unit shall be disconnected from its power source during service and when replacing parts.
- If you need to remove the cover for repair or maintenance, be sure to contact the service station or dealer to deal with, do not operate on their own.
- Electronic components can carry an electrical charge even after the product has been turned off. For safety, turn off unit power. Wait five minutes to allow capacitors to discharge. Then disconnect the power cord from the wall socket (if applicable.) Only after such steps have been completed should covers be removed and electronic components accessed.
- Unplug the product and wait ten minutes before performing maintenance.

MAINTENANCE Maintenance Checklist

If there is a need for maintenance of components, please visit the SportsArt website.

The disinfectant has to be in compliance with Regulation (EU) 2017/745, MDR and Regulation (EU) 528/2012, BPR

It is suited for sensitive synthetic surfaces such as synthetic leather, polycarbonate (PC), acrylic glass and polysulfone, and for the keyboards and control panels.

Maintenance Checklist							
Item		Daily	Weekly	Monthly	Seasonally	Yearly	Remarks
1	Appearance of the machine	•					Clean.
2	Screws of the machine	•					Check if they are loose.
3	Seat Cushion	•					Use damped cloth to clean
4	Pedals	•	•				Inspect the looseness and fix

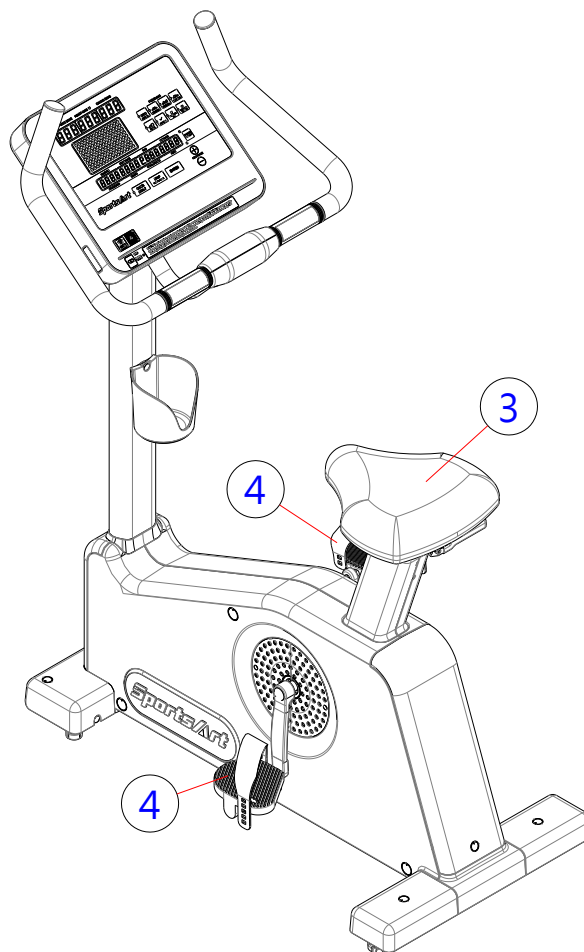

MAINTENANCE Maintenance Log

Facility: _____ Supervisor: _____

Product model number: _____ Serial number: _____

Start date: _____ End date: _____

Daily Tasks	Week 1-7							Week 8-14							Week 15-21							Week 22-28									
Completed																															

Daily Tasks	Week 29-35							Week 36-42							Week 43-49							Week 50-52									
Completed																															

Weekly Tasks	Week 1-7							Week 8-14							Week 15-21							Week 22-28									
Completed																															

Weekly Tasks	Week 29-35							Week 36-42							Week 43-49							Week 50-52									
Completed																															

Monthly Tasks	1	2	3	4	5	6	7	8	9	10	11	12
Completed												

Quarterly Tasks	Quarter 1	Quarter 2	Quarter 3	Quarter 4
Completed				

Yearly Tasks	Year 1
Completed	

Notes: _____

MAINTENANCE Disassemble Plastic

Push the console mast cover (A04) at (A) upward first when disassembling the left and right covers of the mainframe, and then follow sequence of index numbers 1 through 4 assigned to the figure below to disassemble the product. Make sure that remove all the retaining screws before performing disassembly. Push the neck cover (A02) at (B) downward first when disassembling the console, and then follow sequence of index numbers to disassemble the product.

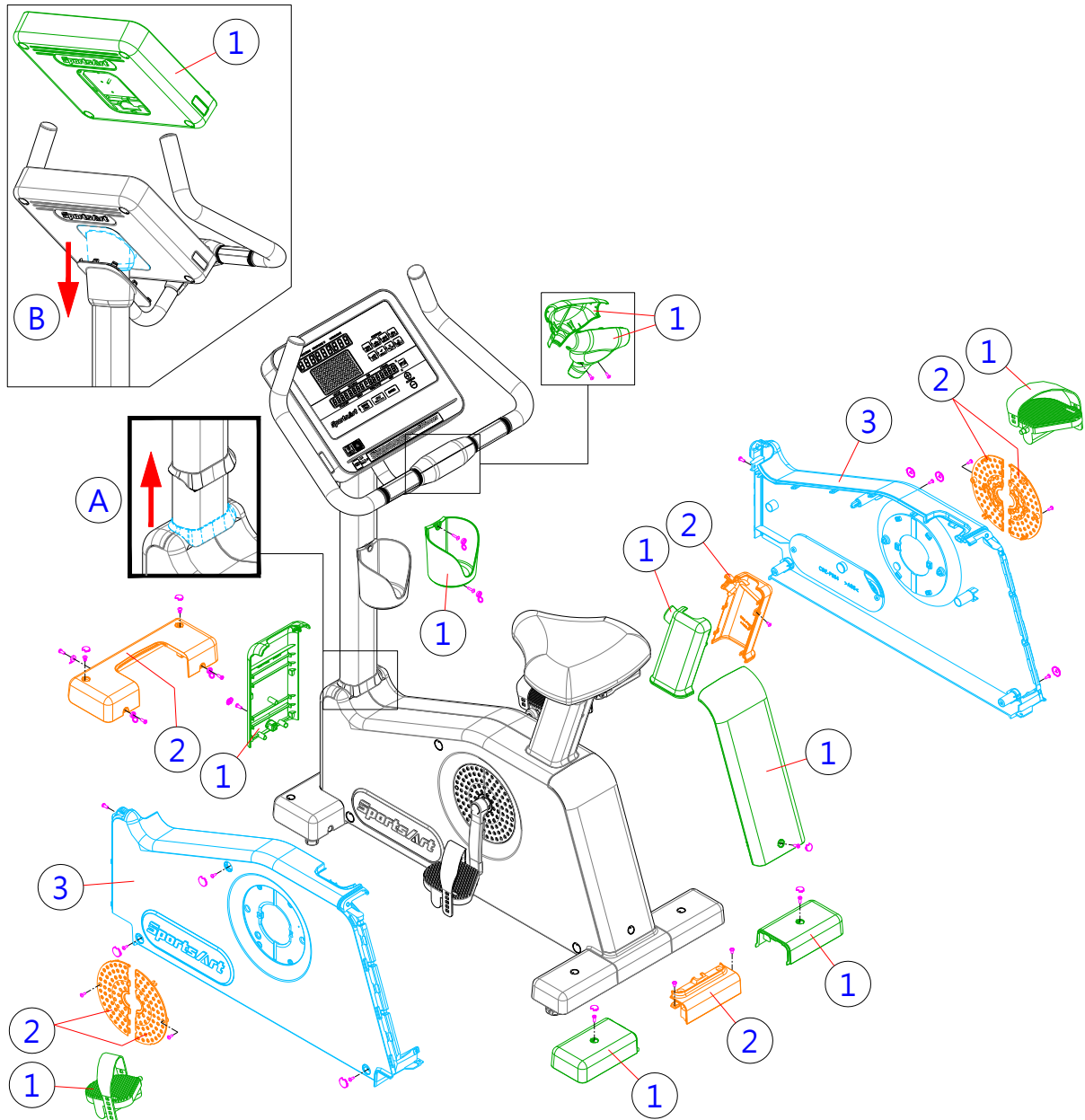

12. Optional accessories

Optional accessories SA WELL+ Member System

This is designed specially by SportsArt to assist the user in managing their workout history.

1. Using a smartphone, connect to the unit via Bluetooth/WIFI and use the SA WELL+ App.
The App is available for download in the App Store and Google Play.
2. Using our SA WELL+ app, you can scan the QR code or tap the NFC tag on the console to connect with the product.
3. Manage user information and workout data Visit "<https://sawellplus.gosportsart.com/>" for more information about this feature.

13. APPENDIXES

APPENDIXE Specification

Model	C565U
Dimensions	L : 1075 mm (42.3") W : 640 mm (25.1") H : 1445 mm (56.8")
Net Weight	55.5kg (122.1 lbs)
Maximum User Weight	180kg (400 lbs)
EN957 Classification	Type 5 /Class SB
Power Requirement	Self-generating
Braking System	Speed-Independent

APPENDIXE Charger Specification

Output DC Voltage	18V
Output Rated Current	1.38A
Output Rated Power (max.)	25W
DC Output Plug	<p>2.1 φ X 5.5 φ X 11mm, C "+"</p>

APPENDIXE Machine Battery Specification

Dimensions	L : 91 mm W : 70 mm H : 102 mm
Nominal Voltage	12V
Nominal Capacity	4AH / 20HR
Terminal	Faston tab : 187/250

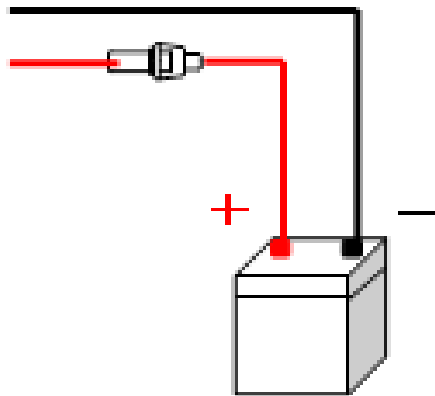
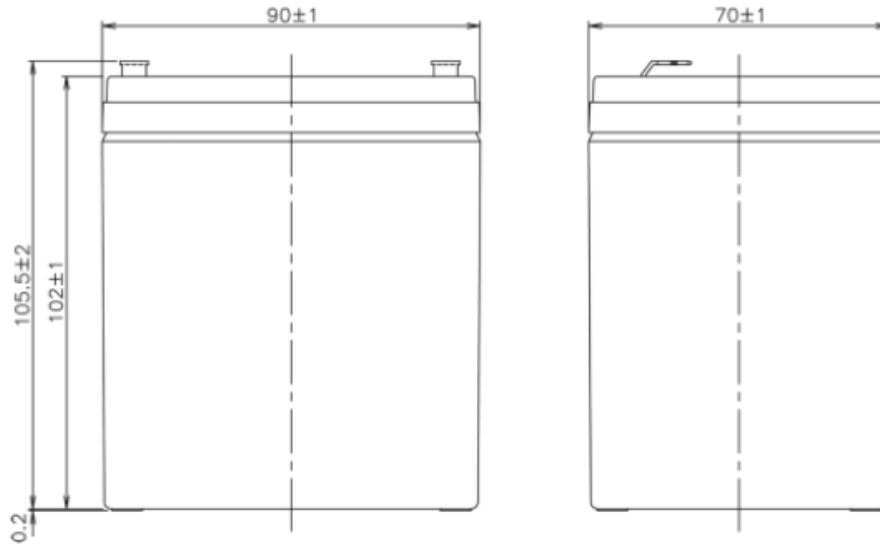

APPENDIXE Error Messages

The window will show the error message when an unusual situation occurs on the machine. (Shown as illustration below, X is for the main code, Y is for the secondary code.)

Error Code Description:

Main Code X	Secondary Code Y	Error message	Note
7	1	When the number of resistance segments is changed, the gearwheelbox set voltage value does not change.	The remaining functions of the machine can be operated normally, but the motor of the gearwheelbox stops rotating. Please turn off the power of the machine and check the circuits of the gearwheelbox set and the driver Board.
7	2	The gearwheelbox set voltage is outside the upper or lower limit range.	

APPENDIXE Electronics Block Diagram

C565U

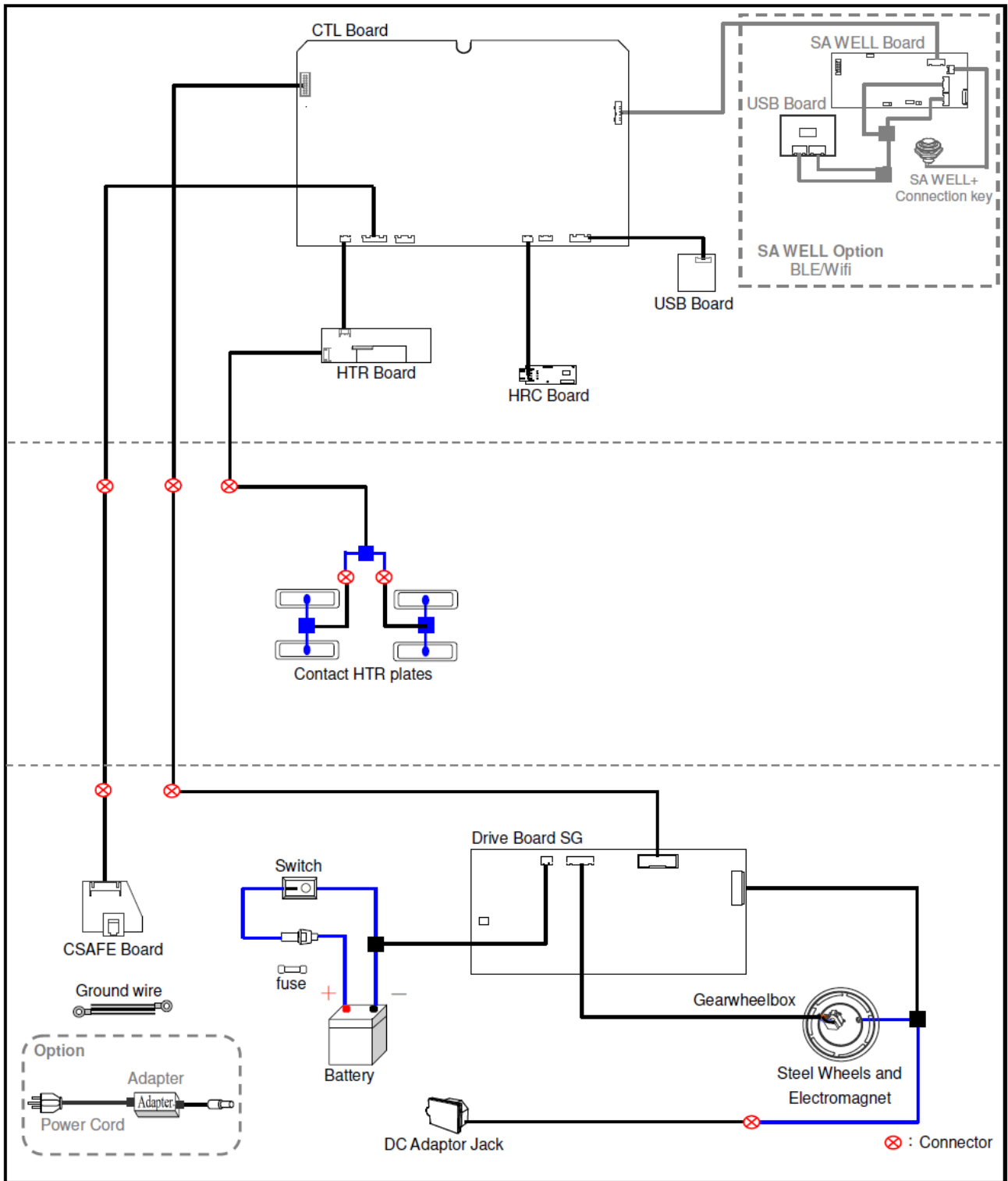



**SPORTS ART INDUSTRIAL CO., LTD.
(Headquarters)**

No. 11, Gong Huan Road, Tainan City,
70955 Taiwan

TEL: +886 6 3840 888

FAX: +886 6 3840 999

E-mail: info@sportsart.com.tw

EUROPE, MIDDLE EAST & AFRICA

Via Risera 14,
CH-6556 Leggia,
Switzerland

TEL: +41 91 8273908

FAX: +41 91 8273910

E-mail: info.emea@gosportsart.com

NORTH & LATIN AMERICA

5900 36th ave W building C, suite 100
Everett, WA 98203
USA

TEL: +1 425 4819479

FAX: +1 425 4888155

E-mail: info@gosportsart.com

CHINA

No.8 Chuangye East First Road,
Shuanglin Area, Liangang Industrial Zone,
Jinwan District, Zhuhai, Guangdong, China
E-mail: info@sportsart.com.cn