

C574R-13" OWNER'S MANUAL CONTENTS

DISCLAIMER	3
1. INTRODUCTION	5
2. SAFETY PRECAUTIONS	6
3. WARNING LABEL POSITION	10
4. LIST OF PARTS	11
5. ASSEMBLE THE PRODUCT	13
STEP 1 Install the Seat and Pedal	13
STEP 2 Install the Handlebar/Saddle/Grip	14
STEP 3 Install the Seat back and Bottle rack	15
STEP 4 Install the Console and Console Mast	16
STEP 5 Move the Bike in place	17
STEP 6 Level the Bike	18
STEP 7 Install the Power Cord	19
STEP 8 TV and Network Function	20
STEP 9 Seat Back Adjustment	21
STEP 10 Seat Fore and Aft Adjustment	22
STEP 11 Essential Functions Guide	23
STEP 12 MAINTENANCE Circuit Breaker	24
6. UNDERSTAND THE SENZA CONSOLE	25
DISPLAY Overview	25
DISPLAY Console Panel	25
DISPLAY Specifications	26
DISPLAY Button Function	26
7. OPERATE THE PRODUCT	27
OPERATION Safe Operating Area	27
OPERATION Proper Workout Position	28
OPERATION Safely Get On/Off	29
OPERATION Start Screen	30
OPERATION GO mode	31
OPERATION Workout Selection	32
OPERATION Workout Status	34
OPERATION Select Entertainment	36
OPERATION View Entertainment	37
OPERATION Workout Summary	37
OPERATION COOL DOWN	38
OPERATION Idle Mode	38
OPERATION Energy Smart Function	38
OPERATION Precautions	38
OPERATION SA WELL+	39

C574R-13” OWNER’S MANUAL CONTENTS

8. ABOUT HEART RATE DETECTION	40
HEART RATE Telemetry	40
HEART RATE Contact	40
9. GUIDELINES FOR EXERCISE	41
10. MAINTENANCE	42
MAINTENANCE Safety Precautions	42
MAINTENANCE Error Messages	43
MAINTENANCE Clean Schedule	43
MAINTENANCE Lubrication	44
11. ACCESSORIES	45
ACCESSORIES Standard	45
ACCESSORIES Option	46
12. APPENDIXES	47
APPENDIXES Specifications	47
APPENDIXES Wiring Diagram	48
APPENDIXES Exploded Diagrams.....	49
APPENDIXES Product Disassembly	50

DISCLAIMER

The information in this user manual is subject to change without prior notice.

Sports Art Industrial Co., Ltd. makes no representation or warranty of any kind, express or implied, regarding the marketability of this manual, the suitability for a special purpose, or any other matters.

SportsArt Industrial Co., Ltd. accepts no responsibility for any errors in this manual, or any damages incurred directly, indirectly, accidentally, or continually from the modification, display, or other use of this manual.

A. Internet function:

A1. This machine provides only a web page browsing method for web page and video browsing.

A2. For web page videos, we support only Youku and YouTube.

Note: Some videos may not be viewed due to restrictions resulting from country policies, internal server firewalls, or video formats, etc.

A3. Strongly recommend good browsing environment when using the internet, used wired network and the network bandwidth must be above 10Mbps.

B. IPTV:

1. Supports subnetwork streaming only, no external streaming.

2. Support wired network only, no wifi network.

3. This function is Open IPTV, unable to read any encrypted stream signals.

4. Supports HTTP and RTSP streaming only.

C. Standard USB audios and videos:

1. Not all USB flash drives can be read properly.

2. Not all audio and video formats can be played correctly.

D. Bluetooth functions:

D1. Bluetooth Music (AVRCP V1.5)

Due to the many varieties of, and rapid changes in, mobile phone models, failure of a mobile phone to connect indicates that we currently do not support that phone.

D2. Bluetooth BLE 4.0 Heart Rate Strap

We only support POLAR-compliant Bluetooth BLE 4.0 Heart Rate Straps.

DISCLAIMER (CONT.)

- E. TV:
 - E1. This machine only supports viewing local free TV.
 - E2. This machine may be affected by the local environment, climate, equipment, etc., which may cause poor quality in reception and definition.
- F. This machine does not support the installation of 3rd party APP.
- G. Standard USB charger:
 - Supports charging of GOOGLE-certified Android mobile phones, and Apple iPhone, iPad, iPad air, and iPad mini.
- H. ANYCast:
 - ANYCast isn't available for all cellphones.

1. INTRODUCTION

Congratulations on the purchase of a high quality SportsArt product, the C574R -13" recumbent exercise cycle. Constructed of high quality materials and designed for years of reliable performance, this product was made for full commercial use.

Before this product is assembled or operated, we recommend that you familiarize yourself with this manual. Understanding the correct assembly and operation of this product will help ensure that exercisers obtain their fitness goals safely and successfully.

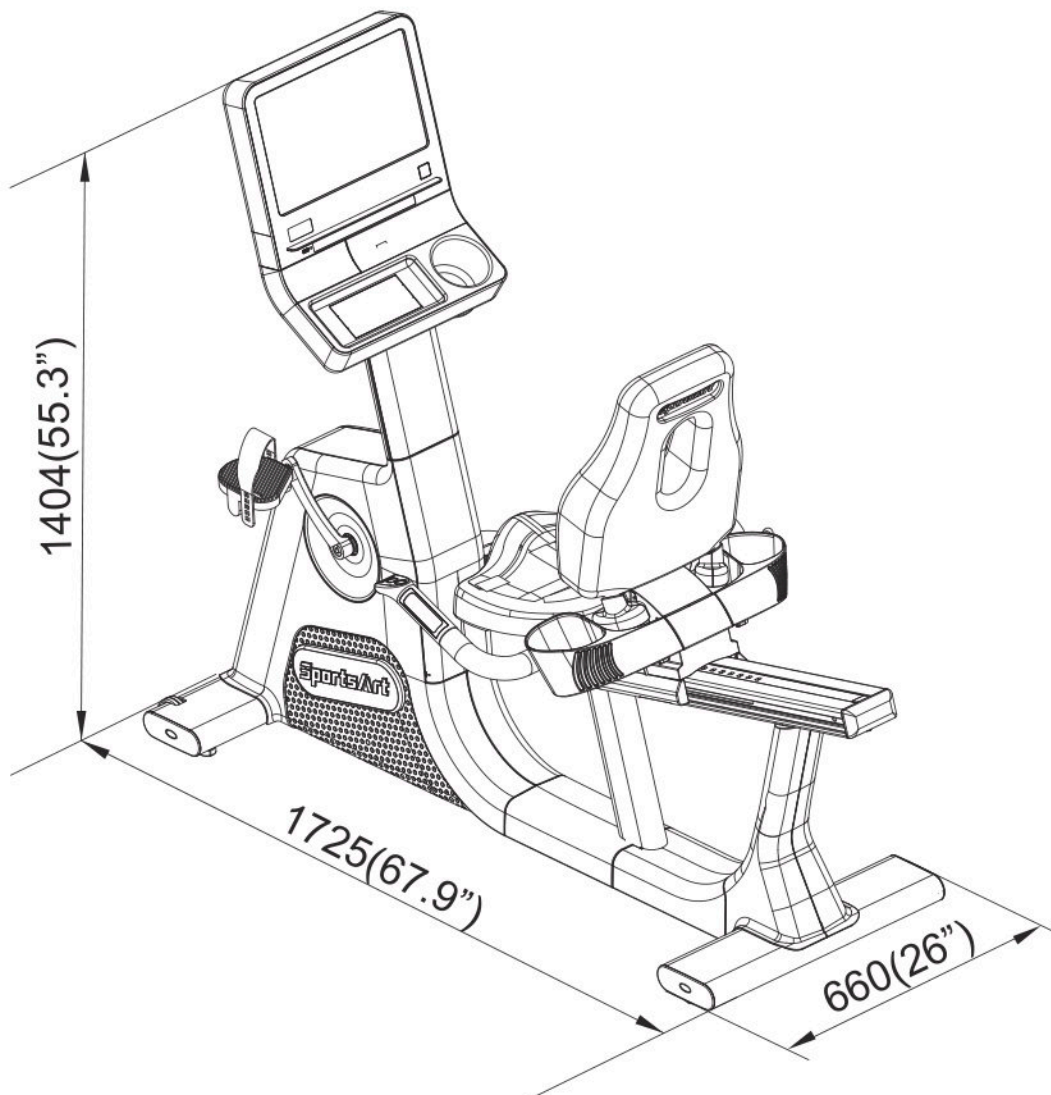

2. SAFETY PRECAUTIONS

This product was designed and built for optimum safety. However certain precautions apply during the use of this product. Please note the following safety precautions:

- To reduce the risk of personal injury, read and understand all the instructions before using this product.
- Make sure the product is installed and operated as instructed in this manual. Be careful when mounting and dismounting the unit. The product shall be disconnected from its power source during service and installed and when replacing parts.
- Use this product only for the intended use described in this manual.
- Check the product before every use. Make sure all parts are assembled, and all fasteners are tightened. Do not use the product if it is disassembled in any way.
- Do not leave your device unattended while in use.
- Assemble and operate the product on a solid, level surface. Do not use outdoors or near water (including swimming pools and saunas) and should not be used where aerosol (spray) products or oxygen are used. Do not operate on a blanket or near flammable materials.
- Keep all air ventilation areas free of blockage. Never drop or insert into any opening.
- Wear appropriate workout clothes, don't wear loose clothing, tie all long hair back, wear shoes with rubber or high traction soles, don't wear shoes with leather soles/high heels or barefoot use this product.
- Never place liquids of any type directly on the unit, except in a bottle holder or accessory tray. Lidded containers are recommended.
- Always use the safety key when operating the product.
- Use the handrails whenever additional stability is required. In case of emergency, such as tripping, the user should grab the handrails and place his/her feet on the side platforms. The handrails may be held to enhance stability as needed, but are not for continuous use.
- Keep away from moving parts. Moving parts may or may not stop immediately if an object becomes caught or impedes normal motion.
- To Avoid Injury, use extreme caution when stepping onto or off of a moving belt.
- Never operate this product if it has been damaged in any way. If it is not working properly, if it has been dropped or damaged, or dropped into water, contact a service technician for repairs.

2. SAFETY PRECAUTIONS (CONT.)

- Do not use accessories or parts that are not specifically recommended by the manufacturer (SportsArt). Such parts might cause injuries or cause the unit to fail and void the warranty. We will not be responsible for any safety issue that arises due to the misuse of accessories or parts. At the same time, we will terminate the warranty terms of this equipment.
- Keep all air ventilation areas free of blockage. Never drop or insert any object into any opening.
- Unpack and verify contents of boxes according to the list of parts to check if any parts are missing. If the product is damaged or missing, contact your SportsArt representative to find out all the materials that were damaged during shipping. (Note: Transport damage is the responsibility of the carrier.)
- This product is not intended for use by persons (including children 14 or younger) with reduced physical, sensory, or mental capabilities, or by people who are otherwise deficient in product knowledge or experience. If such people use this product, they should be given training and be supervised at all times by someone responsible for their safety.
- CAUTION : The heart rate system is for reference only, if you feel any pain or any abnormal feeling, please stop Exercise and consult your doctor immediately.
- Consult your physician before starting a workout or training program. It is recommended that you undergo a complete physical examination. Have your doctor review your training and diet programs to advise you of a workout routine you should adopt.
- WORK within your recommended exercise level. DO NOT work to exhaustion.
- Before using this equipment to exercise, always do stretching exercises to properly warm up.
- Always unplug this appliance from the electrical outlet immediately after using and before cleaning.
- WARNING! Only qualified technicians should be allowed to contact electrical components such as circuit boards. Some components carry an electrical charge even after use has been discontinued or the product has been unplugged. For products with power cords, turn off unit power, wait 10 minutes, then disconnect the power cord from the power socket. For products without power cords, let the unit sit without use for 10 minutes. Only after taking such precautions should covers be removed and electrical components be accessed.
- Do not attempt to drag or carry this unit by the power cord. Keep the power cord away from heated surfaces.
- Do not attempt to modify the plug provided with this product. Proper power supply must be provided. If the plug does not fit an outlet, contact a qualified electrician to inspect or modify power in the facility.

2. SAFETY PRECAUTIONS (CONT.)

- This product must be grounded. If it should malfunction or breakdown, Improper grounding can increase the risk of electric shock. The product is equipped with a power cord having an equipment-grounding conductor and a grounding plug. The plug must be inserted into an appropriate outlet that is properly installed and grounded in accordance with all local codes and ordinances. Check with a qualified electrician if you are in doubt as to whether the power outlet is properly grounded.
- Noise emission under load is higher than without load.
- This equipment has been tested and found to comply with the limits for a Class B digital device, pursuant to part 15 of the FCC Rules. These limits are designed to provide reasonable protection against harmful interference in a residential installation. This equipment generates, uses and can radiate radio frequency energy and, if not installed and used in accordance with the instructions, may cause harmful interference to radio communications. However, there is no guarantee that interference will not occur in a particular installation. If the user desires to correct the interference, it is at the user's own expense.
- The recommended minimum operating temperature is 15 degree Celsius.
- The user weight limit for this product is 205kg (450lb).

If the product is used in a nominal 120V circuit and the rated current is less than 15A with a grounding plug, use a plug like the one shown below:

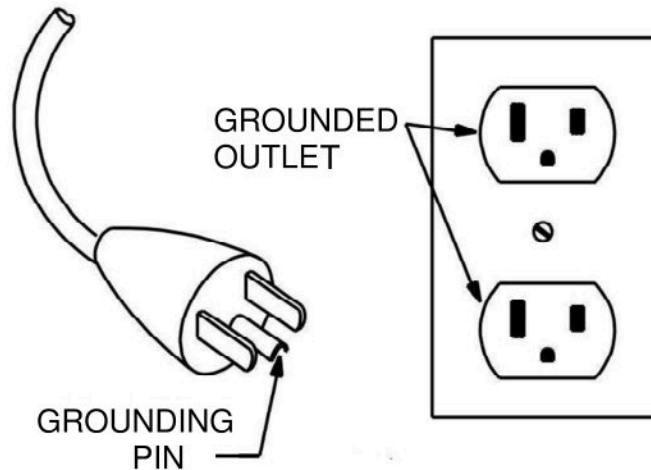

- This product is used in areas with voltage other than 120V. Please use standard socket type according to different countries (grounding is required), and should be configured by qualified electric motor professionals.

2. SAFETY PRECAUTIONS (CONT.)

MARKINGS

CAUTION:

- Read instruction manual before using.
- Do not let children on or near the product.

WARNING:

- Heart rate monitoring system may be inaccurate.
- Over exercise may result in serious injury or death.
- If you feel faint, stop exercising immediately.
- This stationary training equipment is not suitable for high accuracy purposes.

3. WARNING LABEL POSITION

If you are in a Non-English speaking country, you can attach the warning label to the console panel as shown, otherwise, you can also stick it on a place where is clear and obvious. (please use the French version label in French-Speaking areas in North America, and the label will not be included in the other regions.)

Note: Depending on the model, the appearance of the console is different, but the labeling position is the same.

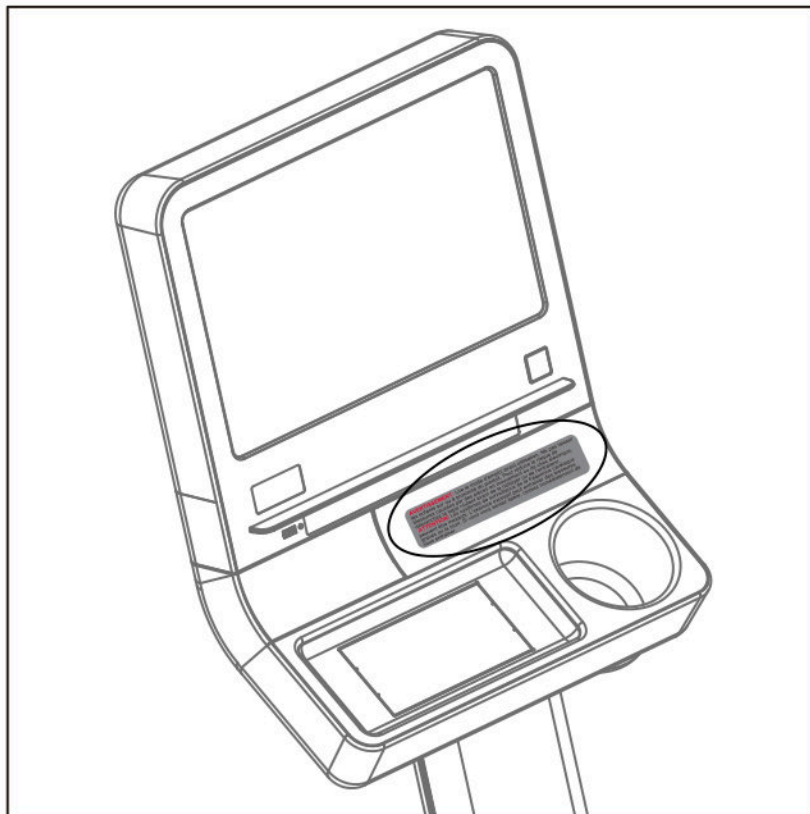

4. LIST OF PARTS

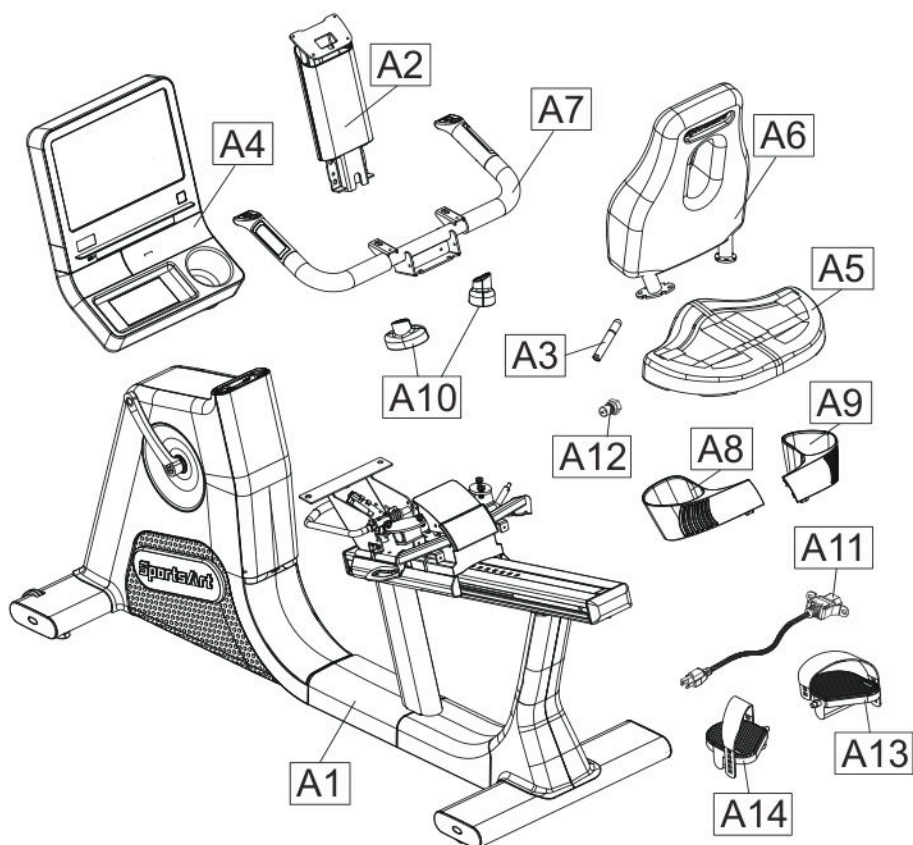

Assembly Parts					
No.	Name	Qty.	No.	Name	Qty.
A1	Main frame	1	A8	Left side bottle rack	1
A2	Console Mast	1	A9	Right side bottle rack	1
A3	Grip	1	A10	Seat strut cover	1
A4	Console	1	A11	Power cord	1
A5	Saddle	1	A12	TV Terminal	1
A6	Seat Back	1	A13	Right pedal	1
A7	Handlebar	1	A14	Left pedal	1

4. LIST OF PARTS (CONTINUED)

Hardware Kit				
No.	Name	Qty.	Specification	Notes
	Double open-end wrench	1	12mm*15mm	
	Double open-end wrench	1	13mm*15mm*20	
	L-shaped Allen wrench	1	M6*L70	
	L-shaped Allen wrench	1	M5*L60mm	
	L-shaped Allen wrench	1	M5*L65mm	
	Two Way Screwdriver + black shank	1	Screwdriver bit (Philips/flat/round)	
10	Round screw cap	1		
11	Philips screw	1	M4*L8	

Components on the Product			
No.	Name	Specification	Notes
22	Inner hex screw	M8*P1.25*L20	
	Spring washer	M8	
	Flat washer	D17*d8.3*t2	
23	Flat washer	D20*d8*t1.0	
	Spring washer	M8*t2.0	
	Outer/inner hex screw	M8*P1.25*L20	
24	Inner hex screw	M8*P1.25*L25	
	Spring washer	M8	
	Flat washer	D20*d8*t2.0	
25	Outer/inner hex screw	M8*P1.25*L20	
	Spring washer	M8	
26	Inner hex screw	M6*P1.0*L15	
	Flat washer	D13*d6*t2.0	
	Toothed washer	D20*d6.2*t2.0	
27	Philips screw	M5*L10	
	Umbrella head self tapping screw	M5*L12	
28	Philips screw	M6*L10	
29	Philips screw	M4*P0.7*L8	

5. ASSEMBLE THE PRODUCT

STEP 1 Install the Seat and Pedal

Use the tool enclosed with the product to secure the left/right pedals (A13/A14) to the crank on the main frame, please note that pedal spindle threads are different from left side and right side. DO NOT install in reverse. The tool should not be too short, otherwise, it can damage the pedals. (please use the attached wrench size in 13*15).

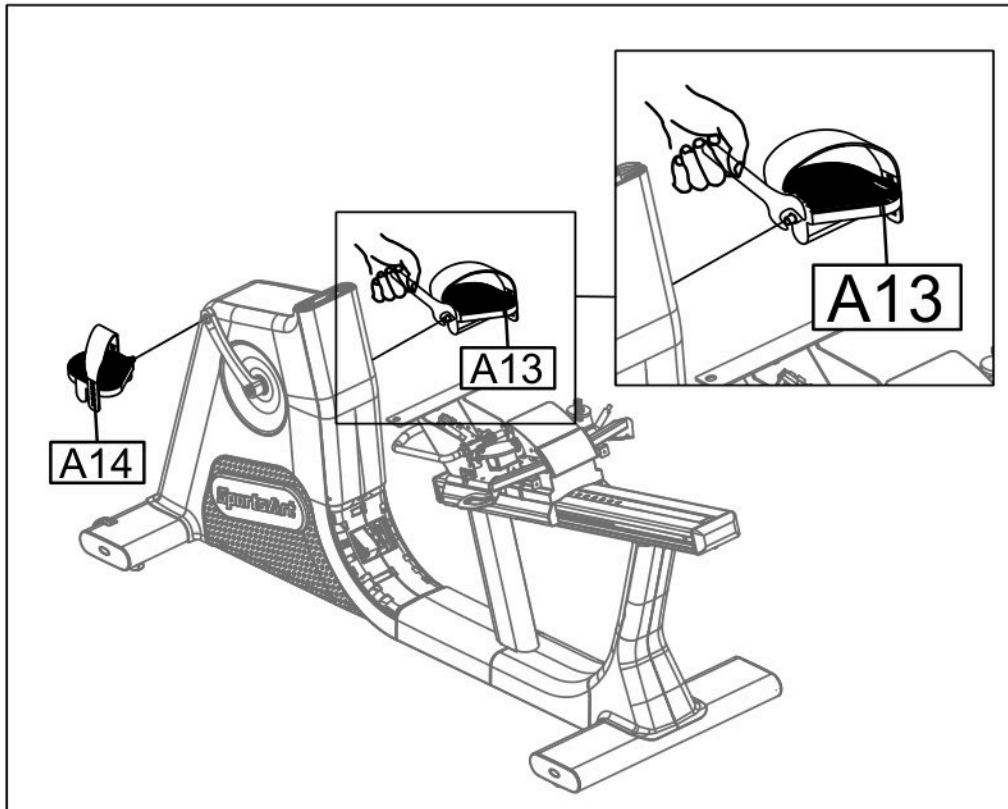

STEP 2 Install the Handlebar/Saddle/Grip

- (a) Secure the handlebar(A7) with the screws (22), pull the cables out of the opening as shown and connect to the cables on the mainframe(A1).
- (b) Secure the saddle(A5) to the mainframe(A1) with the screws (23).
- (c) Turn the grip(A3) onto the mainframe(A1) to fix.

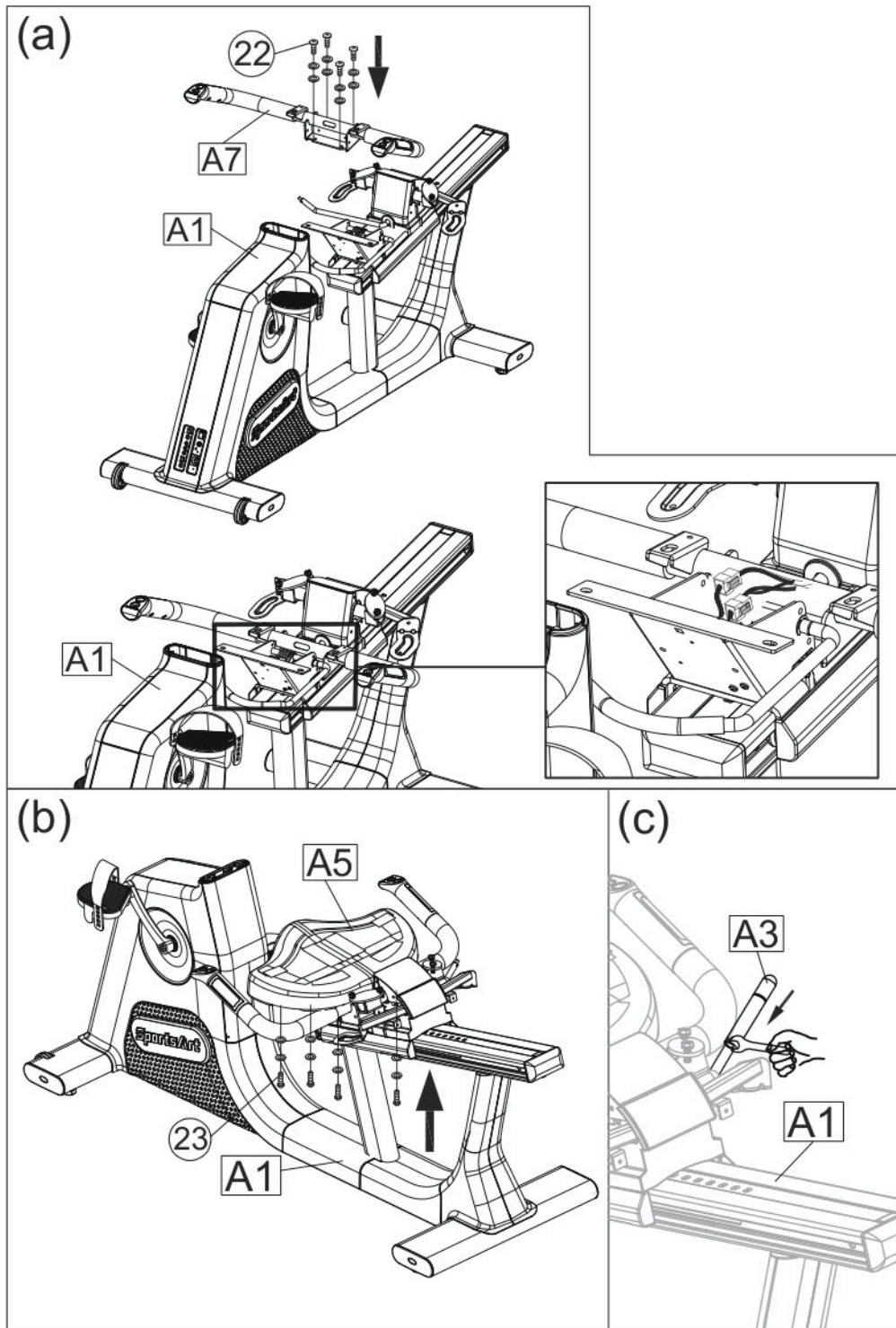

STEP 3 Install the Seat back and Bottle rack

- (a) Secure the seat back(A6) with the screws (25).
- (b) Install the seat strut cover (A10) for both side as shown. (Please note that when assembling the cover, the lower bevel is on the inside and the higher bevel is on the outside of the seat strut.)
- (c) Secure the left/right side bottle rack(A8/A9) to the mainframe(A1) with the screws (27).

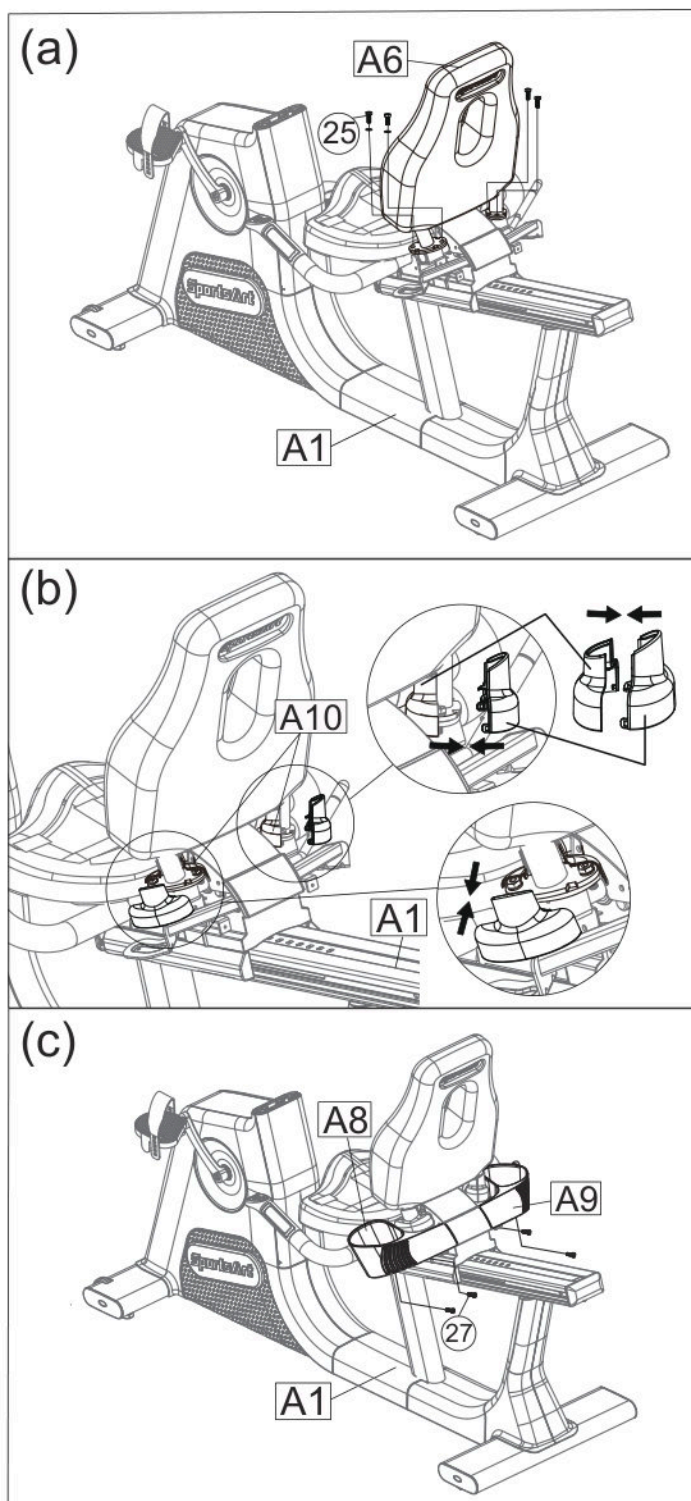

STEP 4 Install the Console and Console Mast

- (a) Remove the maintenance cover (60), then place the console mast (A2) in position and secure it with the screws (24).
- (b) Lift up the anti-slip pad (51) on the console (A4), then remove the screws (28) (11) and the rack (52), and secure the console(A4) to the console mast(A2) with the pre-installed screws (26).
- (c) Remove the rear cover (55), then connect the cables of the console(A4) to the cables of the console mast(A2). After finishing, put the rear cover (55) back, then place the rack (52) and the screws (28) (11) and the anti-slip pad and the round screw cap (10) in order.

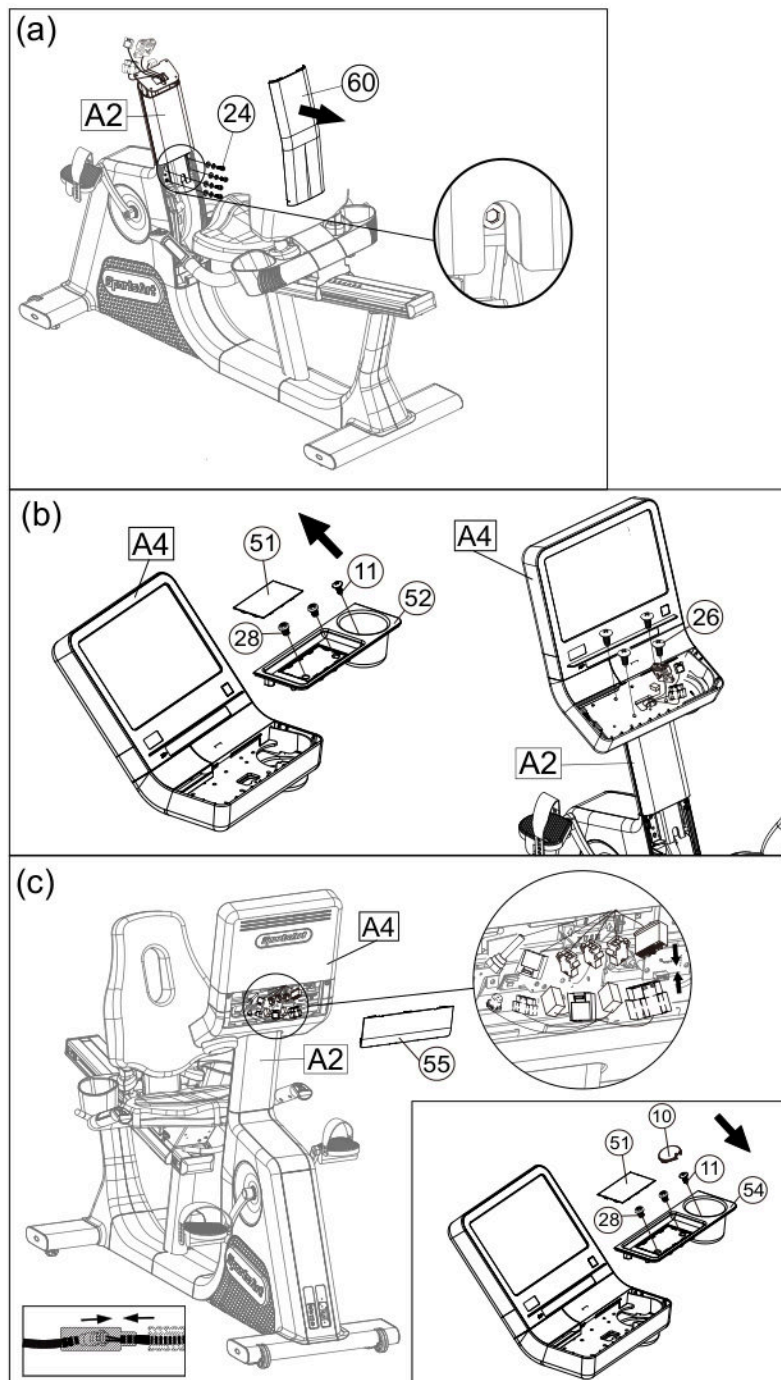

STEP 5 Move the Bike in Place

Lift the seat carriage, then tilt the bike for moving.

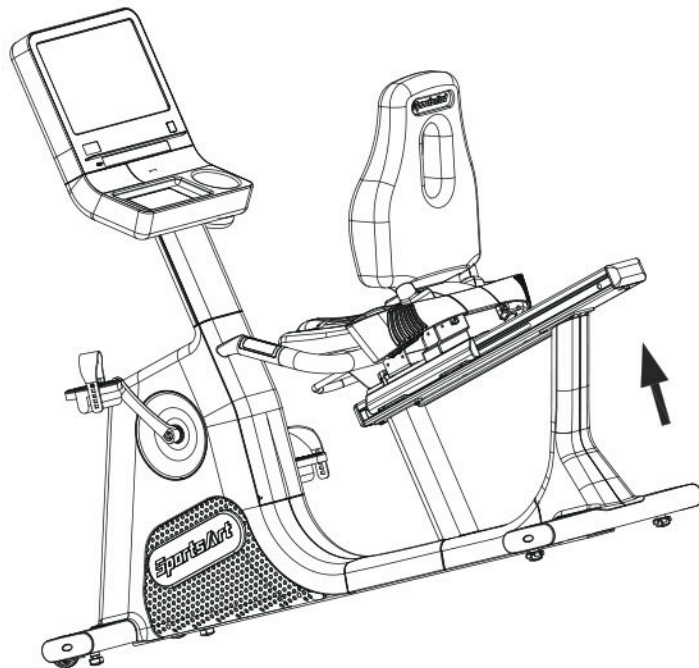
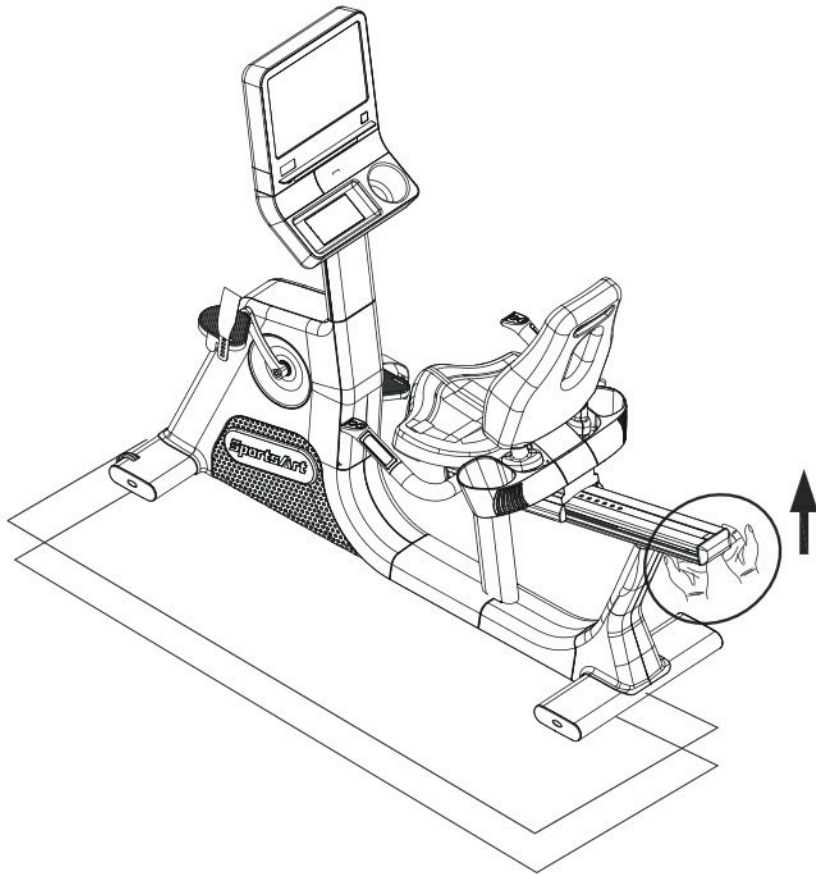

STEP 6 Level the Bike

Please apply force to the end of the bike to check if the leveling knob is stable on the ground.

If not, adjust the levelers as follows:

- (a) Loosen the leveling knob.
 - (b) Rotate the leveling knob downward to the ground to make it steady.
 - (c) Tighten the leveling knob.
- (d) After the bike is installed and positioned, perform the test again. If necessary, make adjustment to be sure the equipment works properly.

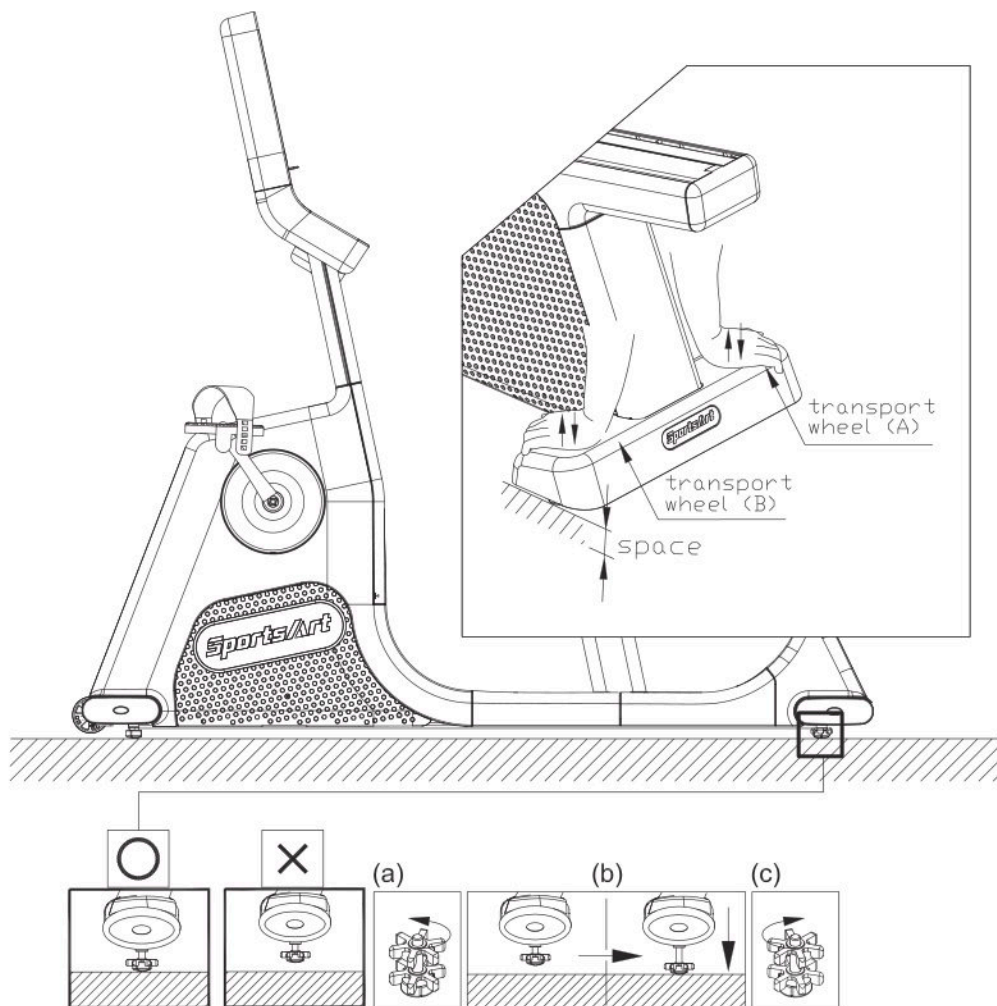

STEP 7 Install the Power Cord

- (1) Remove the screw (29) from the base of the bike.
- (2) Insert the power cord plug into the connector on the product.
- (3) Plug the power cord (A11) into the outlet and secure the power cord plug into place with the removed screw (29).

Note: the figure below is for reference purposes only.

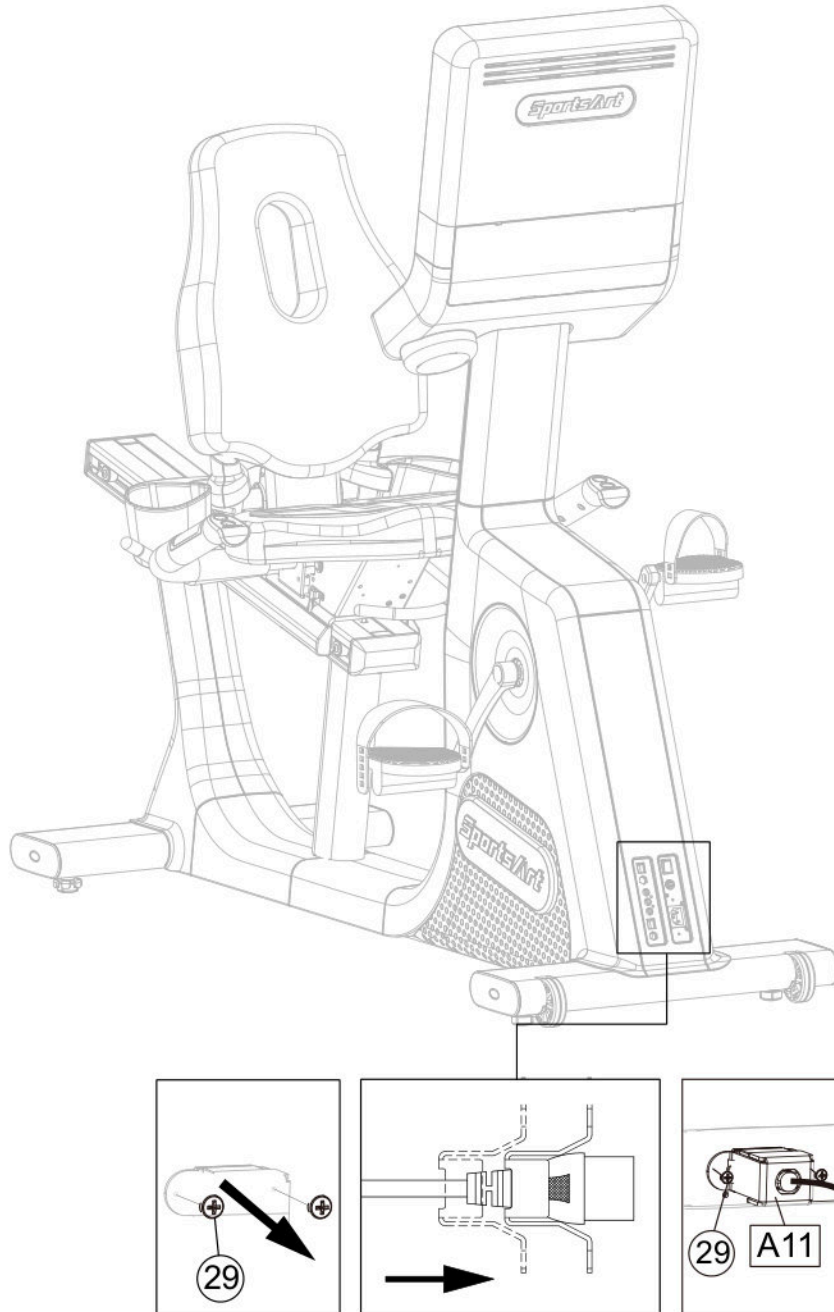

STEP 8 TV and Network Function

- (a) NETWORK: Connect to the Ethernet with the external network signal.
- (b) AV PORT: To support external DVD PLAYER or other multimedia players using AV output signal.
- (c) To support MYE Wireless TV Audio_Channel Receiver, and the other equipment that conform to the CSAFE specification.
- (d) TV : This machine can connect to digital TV and analog TV (for NTSC system). For PAL system, please take out the TV adapter(A12) from tools kit and connect it to TV with cables.

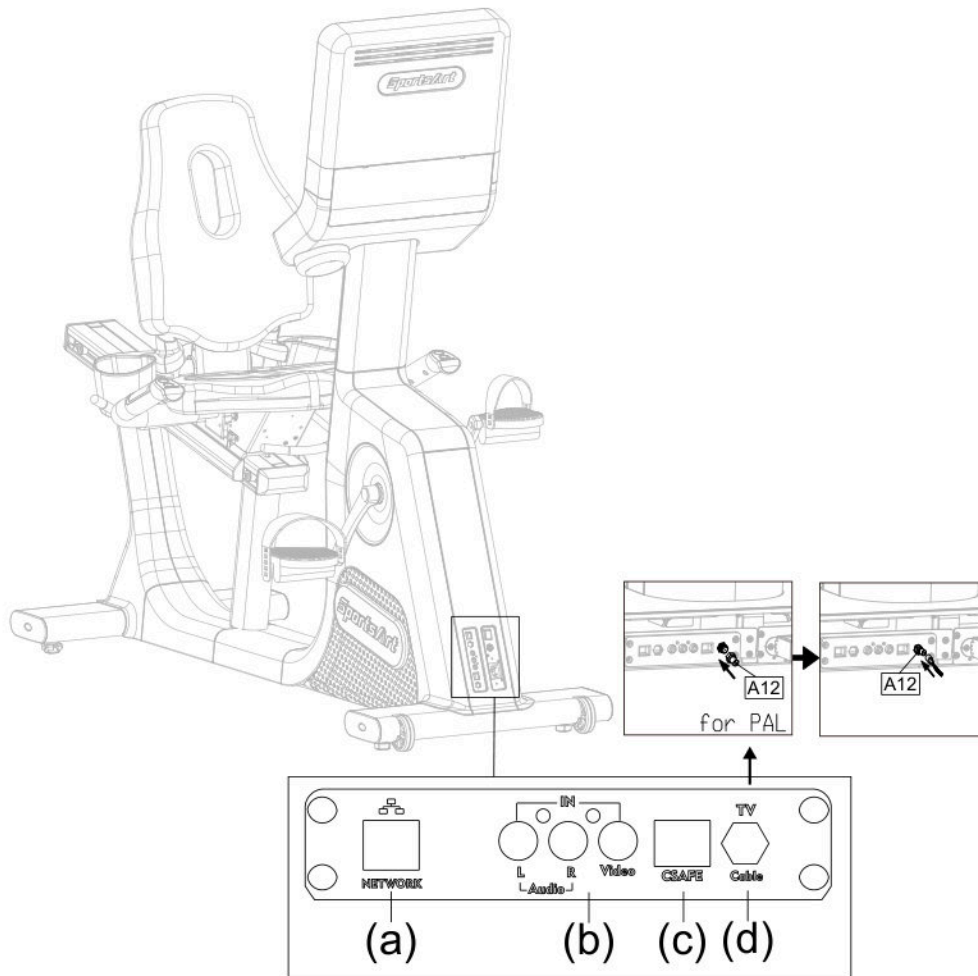

STEP 9 Seat Back Adjustment

Move the grip (A3) left and right to adjust the inclination of the seat back.

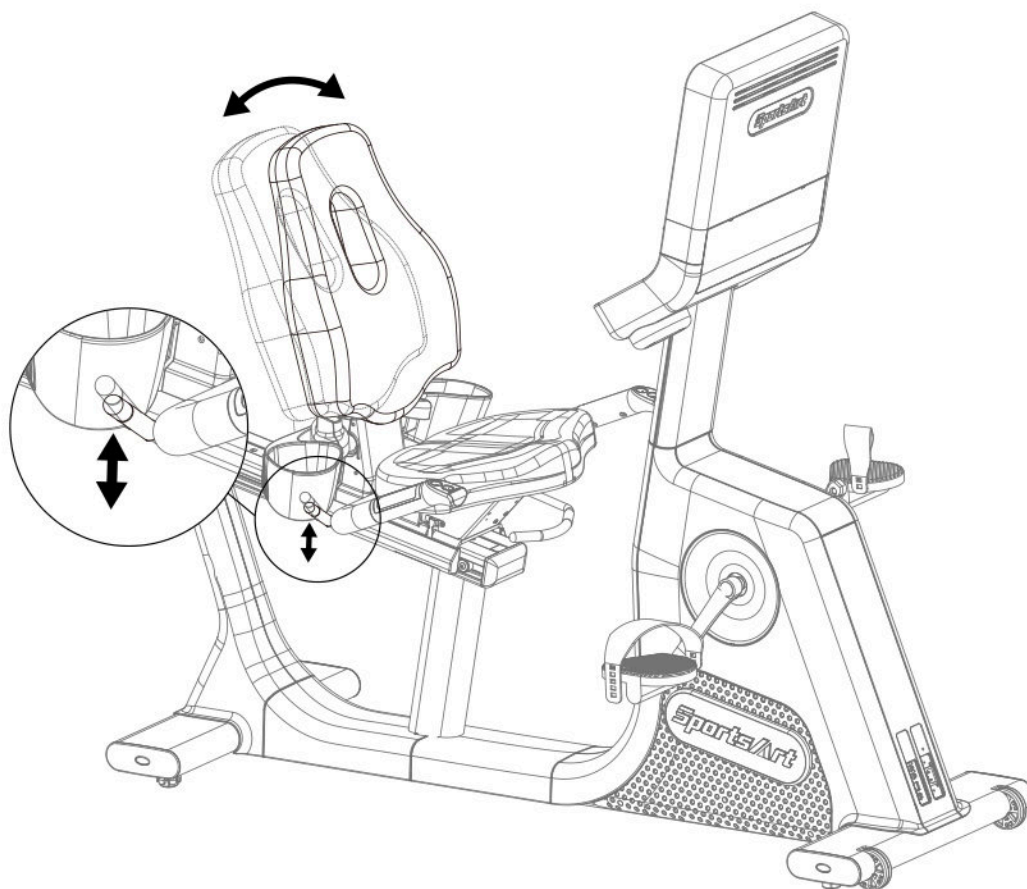

STEP 10 Seat Fore and Aft Adjustment

Pull up the handle right below the seat to move the seat forward and backward until you find the right position.

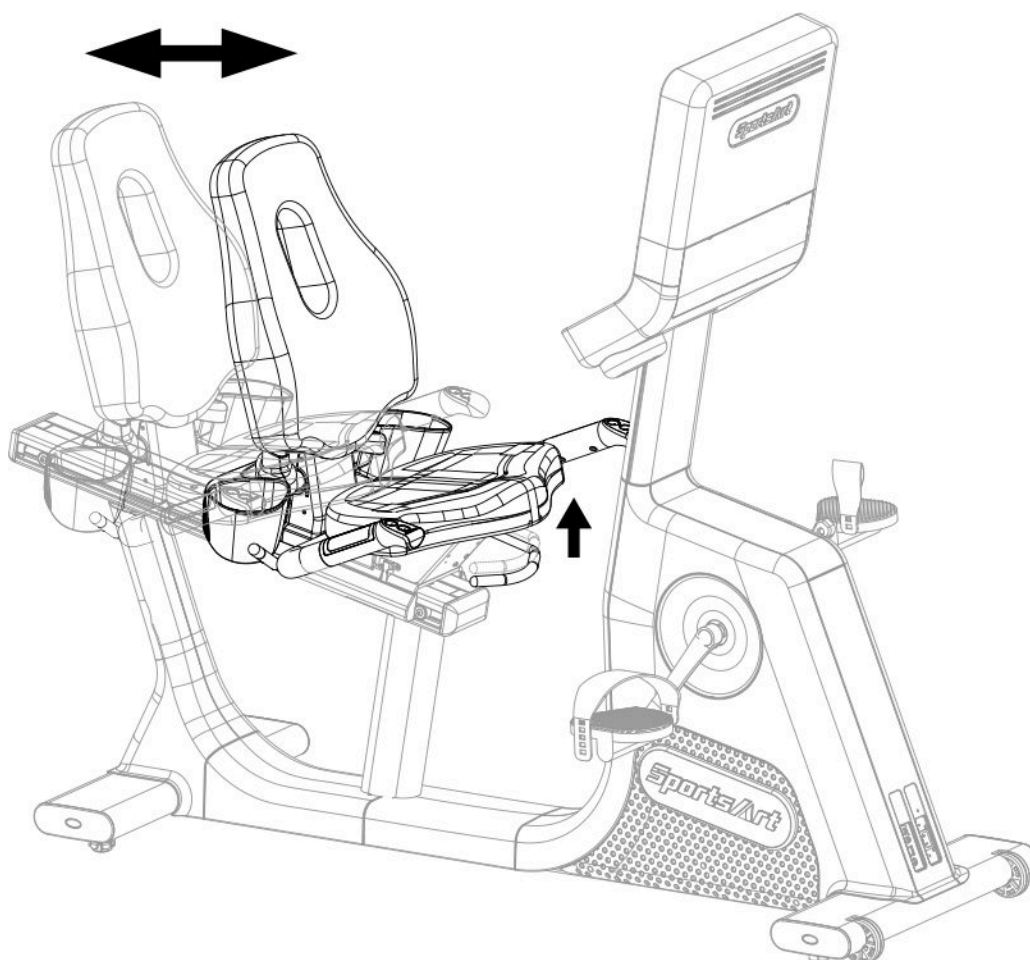

STEP 11 Essential Functions Guide

RESISTANCE: Adjust the weight or force you need to place on the pedals to move them.

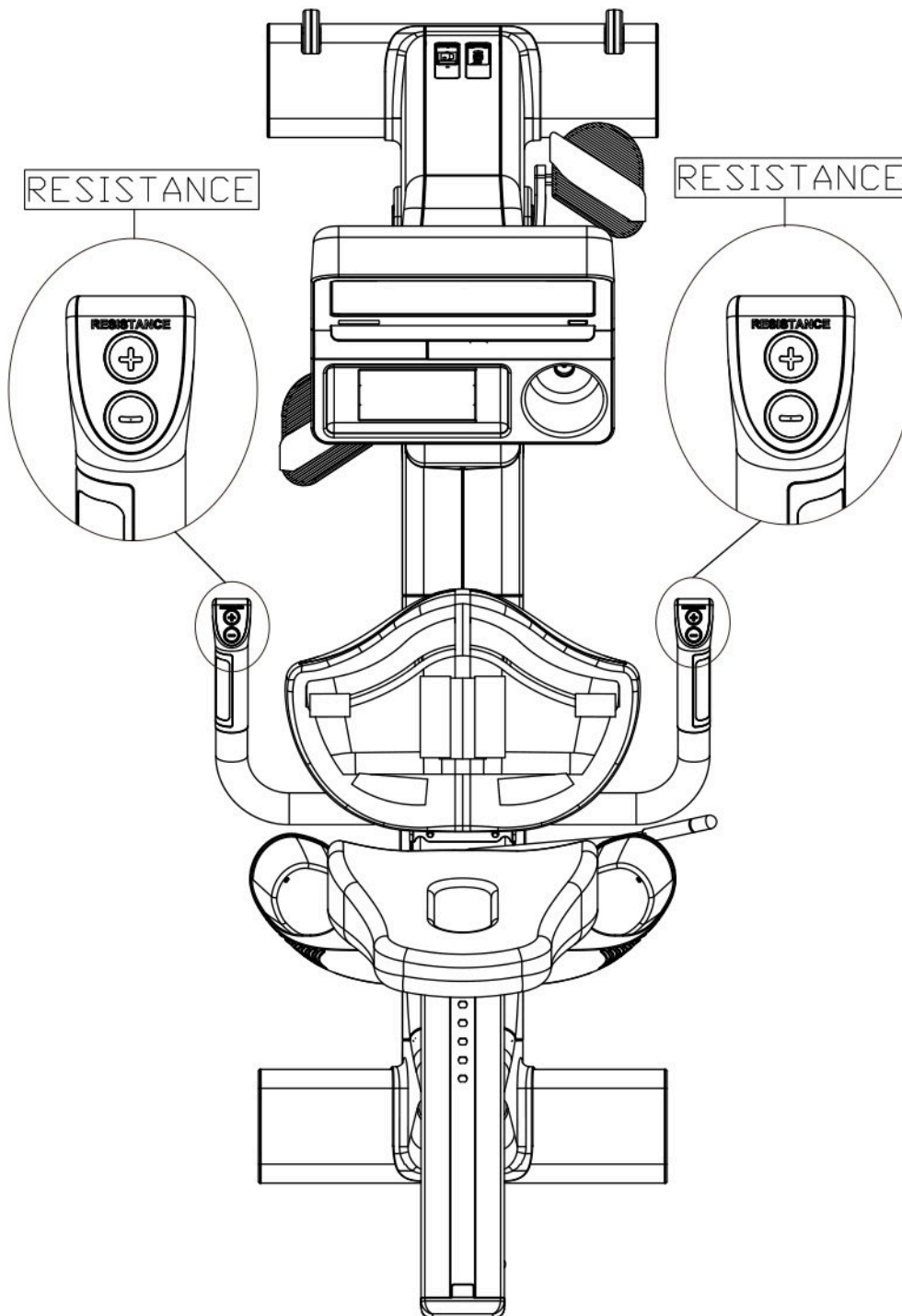

STEP 12 MAINTENANCE Circuit Breaker

- (a) A circuit breaker is an automatically operated electrical switch designed to protect an electrical circuit from damage caused by overcurrent/overload or short circuit. A spring located under the push button at area D to lift up and the breaker to trip as shown.
- (b) After the fault is repaired by qualified technicians, press the push button to reset circuit breaker to resume normal operation as shown.
- The figure below is for reference purposes only.

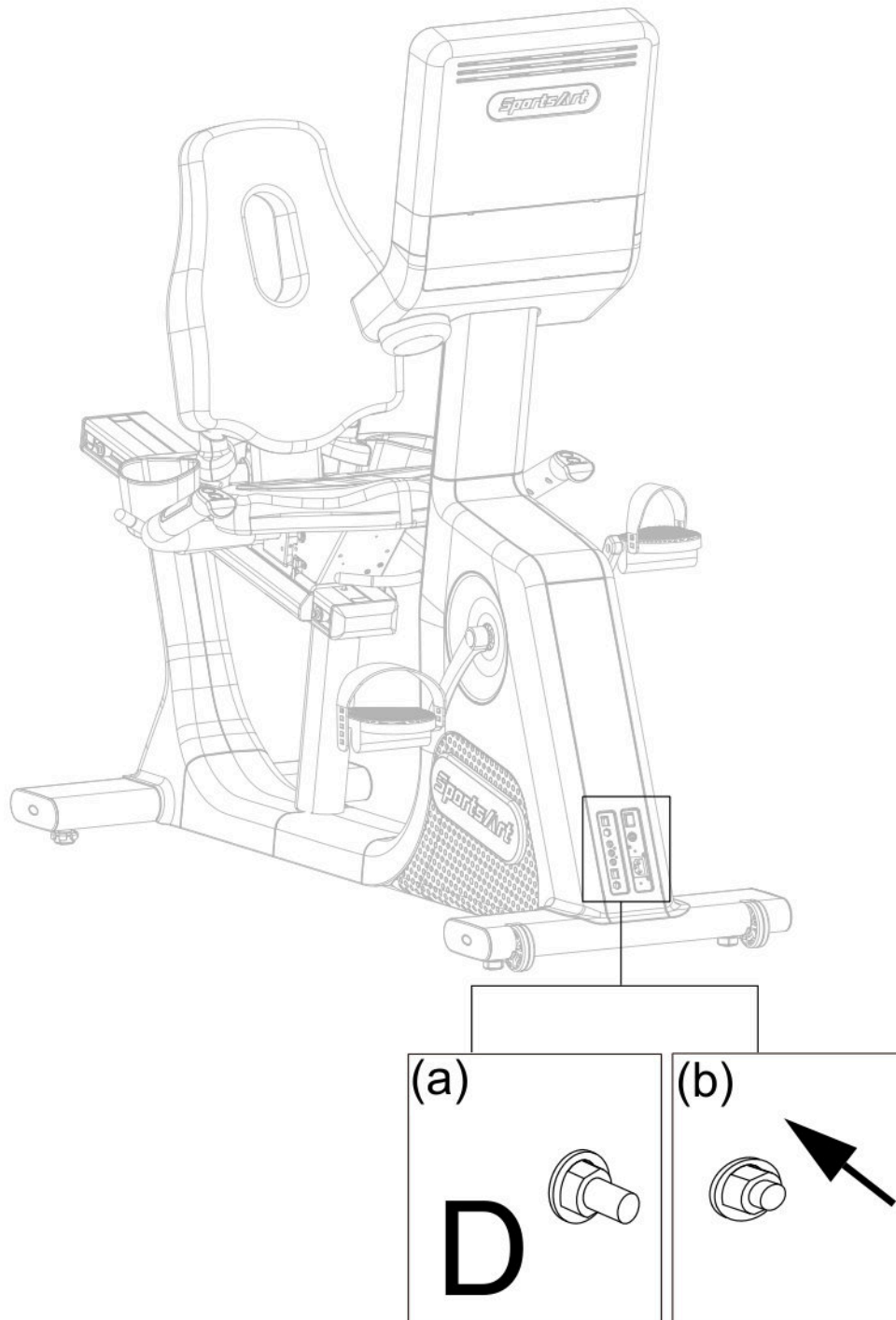

6. UNDERSTAND THE SENZA CONSOLE

DISPLAY Overview

C574R Series 13" Senza Console is designed to help users obtain their fitness goals in a simple and convenient way. Before using the cycle, please familiarize yourself with the features on the display so you can fully utilize the cycle and all it has to offer.

DISPLAY Console Panel



No.	Description	No.	Description
1	QR Code · NFC tag	4	Wake Button
2	USB port	5	Headphone Port
3	SA WELL+		

DISPLAY Specifications

Parameter	Spec.
RESISTANCE	1-40
SPEED	0.0-99.9 MPH or 0.0-99.9 KPH
TIME	0:00 - 600:00 min
HEART RATE	35 - 220 bpm
DISTANCE	0.00 - 9999 Mile/Km
CALORIES	0 - 9999 Cal
RPM	5-150 steps/ min
Calories /Hour	0-9999 Cal/Hour
Mets	0-99.99
PROGRAM	QUICK START, GOALS, FAT BURN, INTERVAL, SENZA JOURNEYS, PLATEAU, HEART RATE, FITNESS TEST

DISPLAY Button Function

Illustration	Description
	Wake up the display from sleep mode.

7. OPERATE THE PRODUCT

OPERATION Safe Operating Area

- (a) Safety clearance required as shown below. Do not allow people to be near this area when operating.
- (b) Noise emission under load is higher than without load.

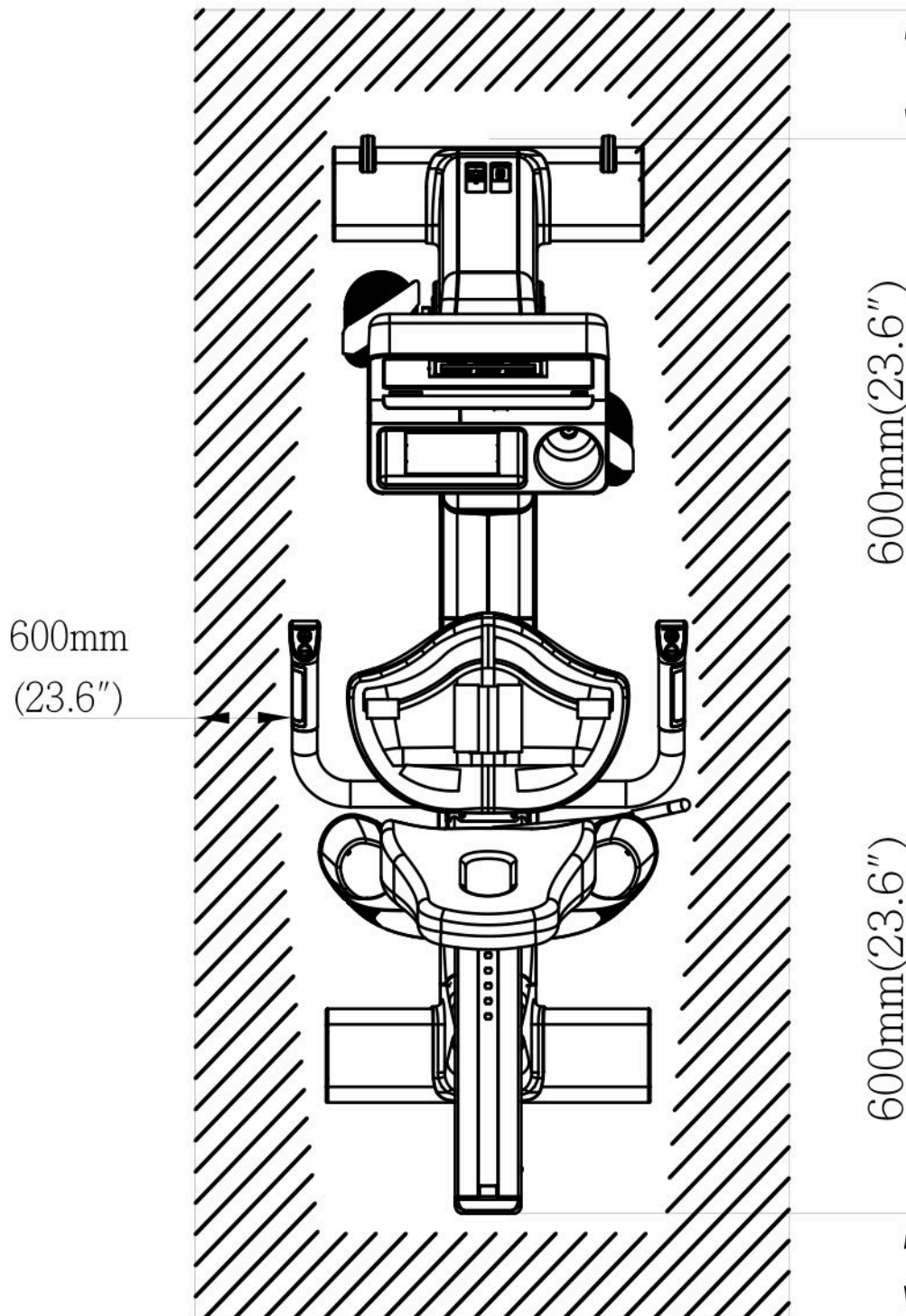

OPERATION Proper Workout Position

- (a) A good riding posture is illustrated below.
- (b) Always follow the directions for use and safety instructions given by the manufacturer. Over exercise or improper workout position may result in serious injury
- (c) Hold onto the handlebar while getting off the bike from left/right side.
- (d) This product is intended to build your leg and cardiovascular strength.
Please note that the speed of lowering the seat should not be too fast.

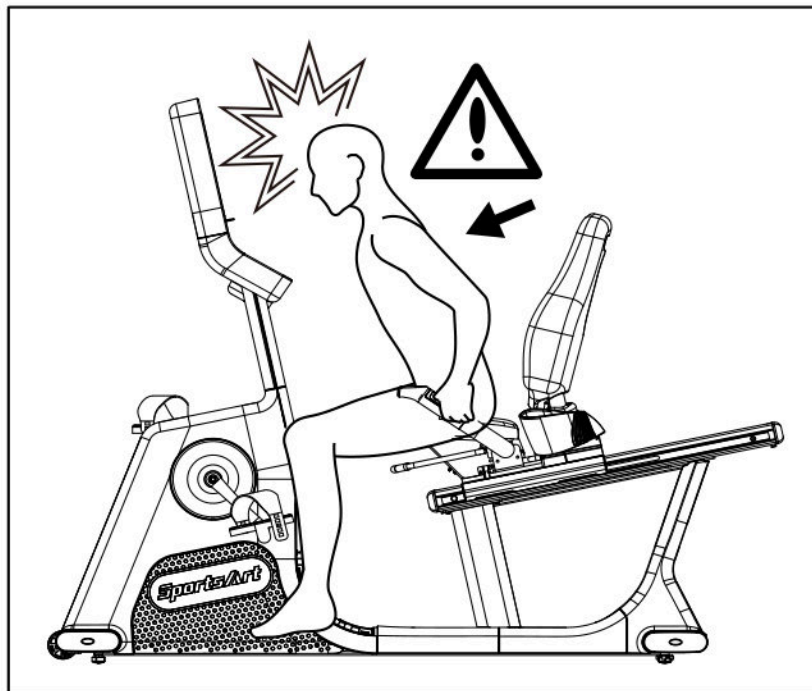
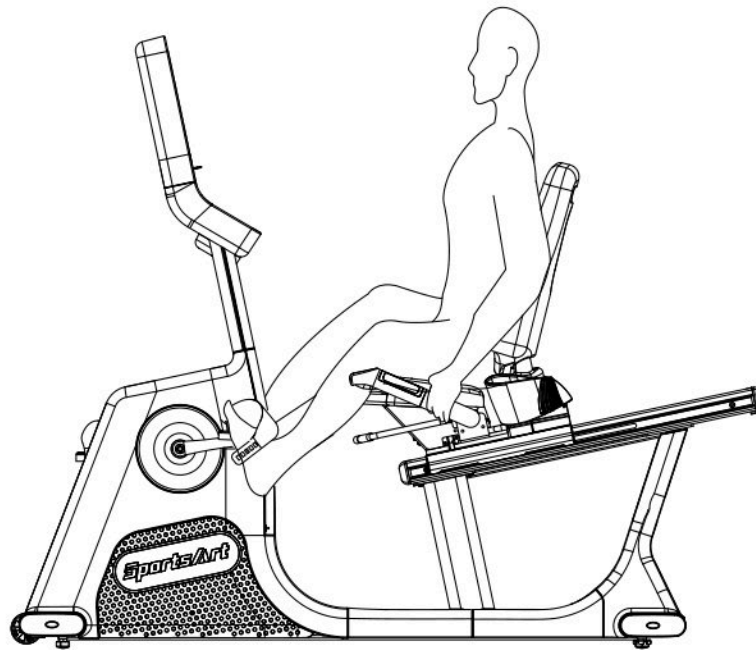

OPERATION Safely Get On/Off

Getting on the bike: Always be cautious when getting on the bike. Wait to get on until the pedals have come to a complete stop.

Getting off the bike: Always be cautious when getting off the bike. Always wait until the pedals have come to a complete stop before taking your feet off of the pedals and dismounting.

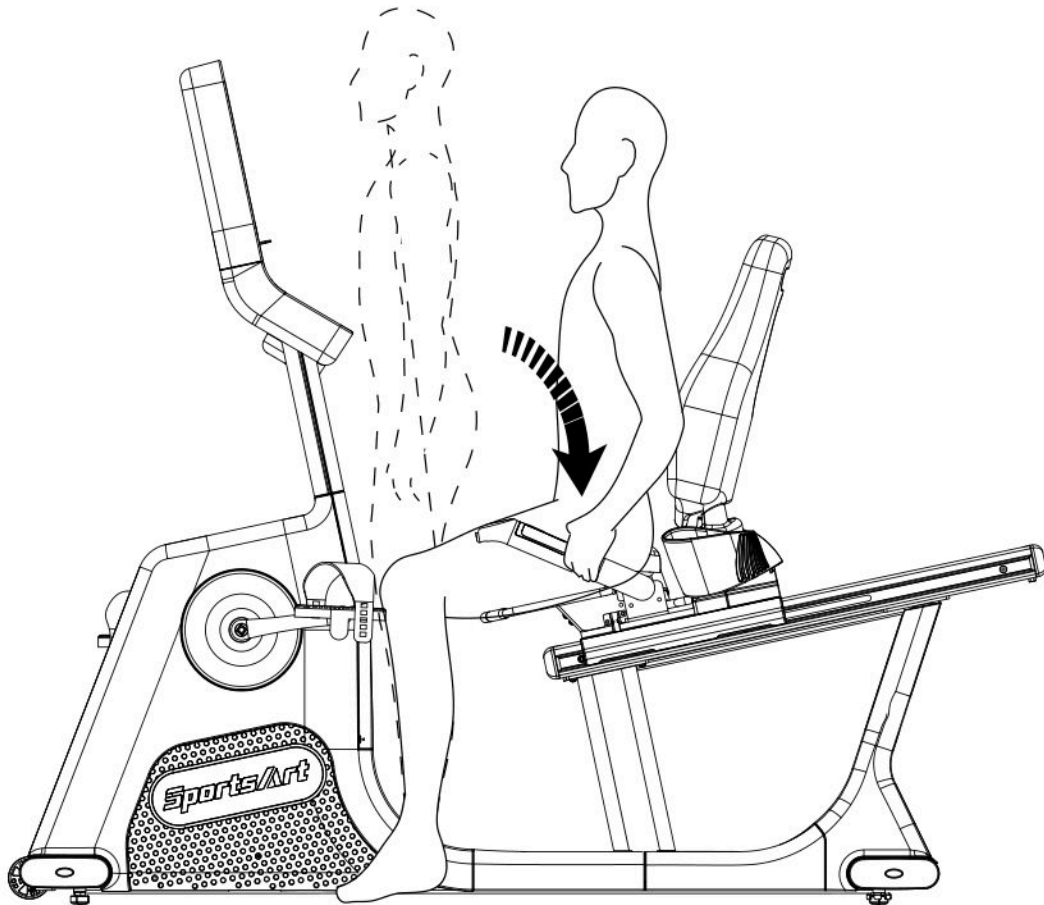

OPERATION Start Screen

Turn on the power or press the wake-up key to go to start screen.



Description of start screen buttons:

No.	Name of button	Function
1	Date and Time	Displays the current time and date
2	SELECT	Touch this button to access workout program selection
3	SA WELL+	Touch to login into the SA WELL+ system
4	BT	Touch it to pair with Bluetooth earphone.
5	HR SELECT	Touch for pairing with Bluetooth or ANT+ heart rate strap
6	LANGUAGE SETTING	Touch to select your preferred language by country
7	DISPLAY MODE	Touch to switch screen to black and white display (with high contrast). Touch again, the screen will switch back to color display
8	ENGINEERING SETTING	Touch to access the engineering mode. This is the maintenance setting for use by technicians. Password input is required to perform the actions of the related settings
9	CUSTOMIZED WEB PAGE WINDOW	Web page status display for browsing and operation
10	FEATURE	Displays various virtual realities. Touch this screen to access the virtual reality training mode
11	GO	Touch this button to start workout

OPERATION GO mode

Press <GO> key, then the screen will start counting down by showing 3,2,1,0,GO on the display.

The product will start with the default setting of 35 years old, weight 75 kg (165 lbs) and the PROGRAM will start in quick start – time mode, with resistance level 1. You can use these default settings to complete your workout or change the settings yourself.

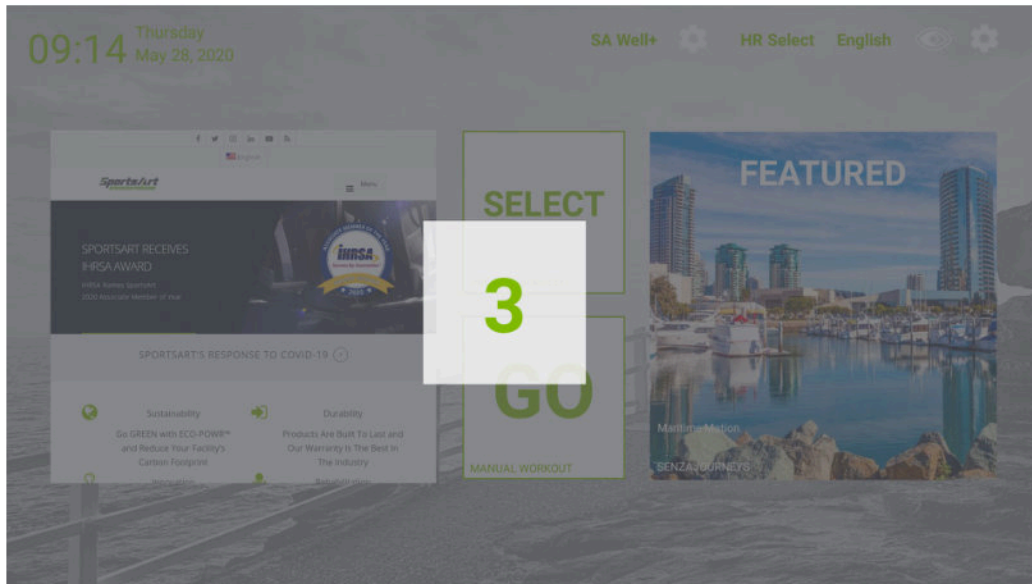

OPERATION Workout Selection



- At start screen, touch the Select icon to access “SELECT WORKOUT”.
Select workouts on the screen:

By swiping with your fingers, you can move between the workout options on the screen. The workout options are as follows: QUICK START, GOALS, FAT BURN, INTERVAL, SENZA JOURNEYS, PLATEAU, HEART RATE and FITNESS TEST. You can switch among these options while exercising. After you choose an option, the workout will start right after a 3 second countdown timer. You can also change to different options while working out.

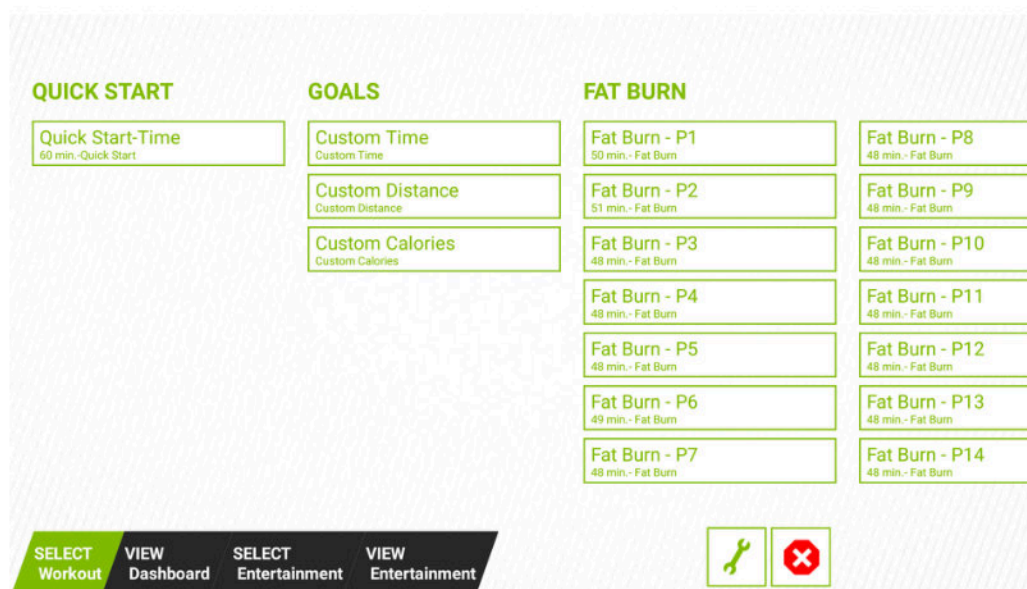
Description: GOALS, HEART RATE and FITNESS TEST won't start right after you choose it, they will need to set up some options before starting workout.



Description of icons on the “Select” screen:

ICON	Description
	Tap to return to startup screen. During exercising, tap it to stop or resume workout.
	Quick Tools

OPERATION Workout Selection (Cont.)

2. Workout selection can choose your own workout programs, here are some details explained below.

QUICK START

A workout mode option based on time, distance and calories that allows user to start a workout immediately.

GOALS

Set your own time, distance, and calorie goal.

FAT BURN

Provides 20 kinds of fat burn modes. Quickly burn out fats in your body by working out with the fat burn mode.

INTERVAL (1:1, 1:2, 2:2)

Interval Training is alternating periods of high intensity aerobic exercise and low intensity aerobic exercise.

Workout time ratios have 3 options, namely 1:1, 1:2 and 2:2.

SENZA JOURNEYS

Built-in or customized landscape films allow the user to watch a video of scenery while exercising.

PLATEAU

Various workout mode options are provided to achieve workout goal.

HEART RATE

A workout mode using heart rate as the target value.

FITNESS TEST

Provides different professional fitness test modes.

OPERATION Workout Status

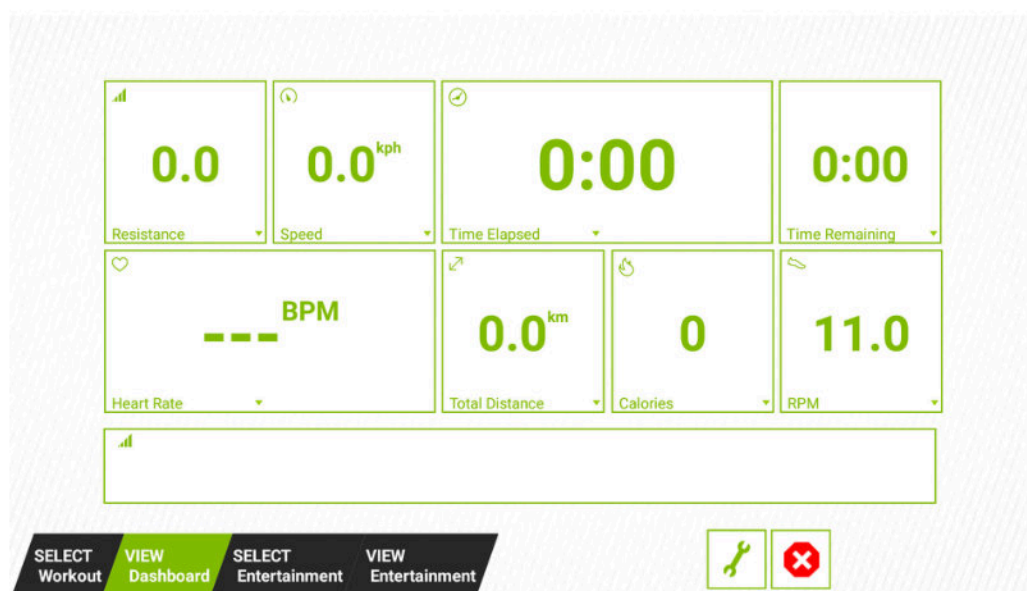

During the workout, you can select the “VIEW Dashboard” page below the screen to check the exercise status of your workout process. There are a total of 9 status windows for various information views, and you can modify the information display format in the status windows by touching the ▼ symbol below the status windows. A drop down menu for information display format will be opened for selection.



Drop down menu introduction:

Symbol	Drop down Menu items	
	Default	Other Options
	Resistance	Average Resistance Human-Watts Change Resistance
	Speed	Average Speed Pace
	Time Elapsed (ex. 0:00 means 0 minute and 00 second)	Time Remaining Clock Segment Duration Target Duration
	Segment Remaining (ex. 0:00 means 0 minute and 00 second)	----
	Heart Rate	Average Heart Rate Max Heart Rate
	Total Distance	Set Target Distance

OPERATION Workout Status (Continued)

Symbol	Drop down Menu items	
	Default	Other Options
	Calories	Calories/Min Calories/Hour Mets Set Target Calories
	RPM	Average RPM Change Speed

OPERATION Select Entertainment

You can select the “Select Entertainment” page below the screen, and the available multimedia features will be displayed. The features include TV, Internet, SENZA Journeys, Bluetooth Audio, USB Audio, USB Video, IPTV and AVIN, ANYcast, Youtube, Netflix, HDMI(optional) etc.: the small central window will display the selected multimedia screen immediately.

Note: A good browsing environment is strongly recommended when using the internet. Wired connection preferred. Network bandwidth must be above 10Mbps.



Description of icons in the “SELECT Entertainment” screen:



ICON	Description
	Mute
	Lower volume
	Raise volume
	Previous
	Play
	Next

OPERATION View Entertainment

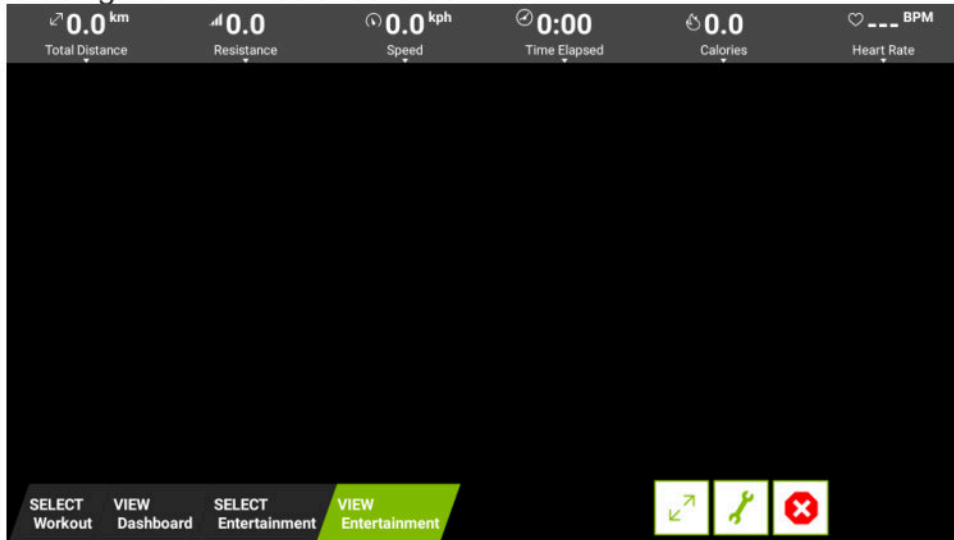
The display mode that maximizes the selected multimedia capabilities; in addition to the multimedia display, a sidebar workout information display is also included, so the user can check their current workout status instantly while using the multimedia features.



Description of icons in the “View Entertainment” screen:

ICON	Description
	Full Screen (Exit full screen mode by tapping screen.)
	<ol style="list-style-type: none"> 1. This button appears when choosing SENZA Journeys workout program. 2. Press this button for fast forward 20% journeys.

OPERATION Workout Summary

At the end of a workout or when you press the stop button, the workout summary screen will appear. The screen shows your current workout status.



OPERATION COOL DOWN

When finishing your target program (time, distance, calories) or when pressing the key “CoolDown Workout”, display will pop up “GOING TO COOL DOWN”, then the machine will enter a two-minute cool down period and count down from 2:00 to 0:00.

OPERATION Idle Mode

When the cycle stops running with no other activity for 2 minutes, the machine will enter the idle mode and the display will show the standby picture. Touch anywhere on the screen to enter the Home page.

Note:

1. The standby picture can be changed and set by the user.
2. Standby time for idle mode can be changed in the engineering mode.

OPERATION Energy Smart Function

There is a default Energy Smart timer setting feature in the engineering mode. When the product is not in use and the set up time for power saving is reached, the system will automatically enter the power saving mode, and the product will turn off for maximum power saving. Press the Wake Up button to turn the power back on.

OPERATION Precautions

1. Turning the product on and off every day will make your software system refresh and stable. Please wait 5 minutes before turning the product back on when restarting.
2. SanDisk USB (Fat32, MAX 32GB) is recommended for updating the program.

OPERATION SA WELL+

Tap SA WELL+ to enter SA WELL+ Login page.

First time user must create a user account with SA WELL+ App. After signing up, user information will be saved into the account.

Login to your SA Well+ account to track your workouts. This will also allow you to download a created custom workout to the machine.

There are two ways to login:

1. Without mobile device on hands, please manually enter SA WELL+ ID and password.
2. With mobile device on hands, please follow up below steps.
The instant information is shown on the cell phone.
 - 2-1. Open SA WELL+ APP
 - 2-2. Tap the "Scan QR code" button
 - 2-3. Scan QR code as instruction shown on your phone.

If your equipment is not equipped with SA WELL+, Login page will be shown as the following figure.

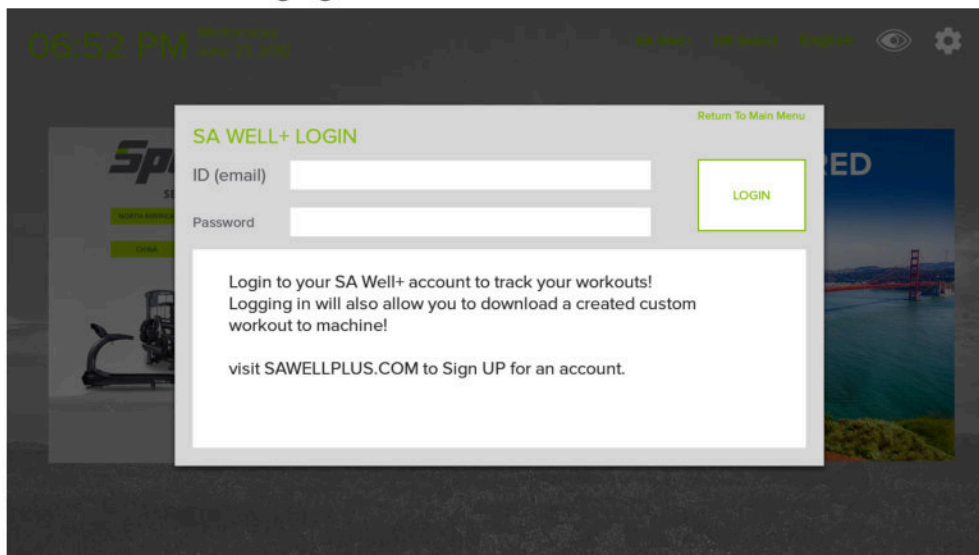

If your equipment is equipped with SA WELL+, Login page will be shown as the following figure.

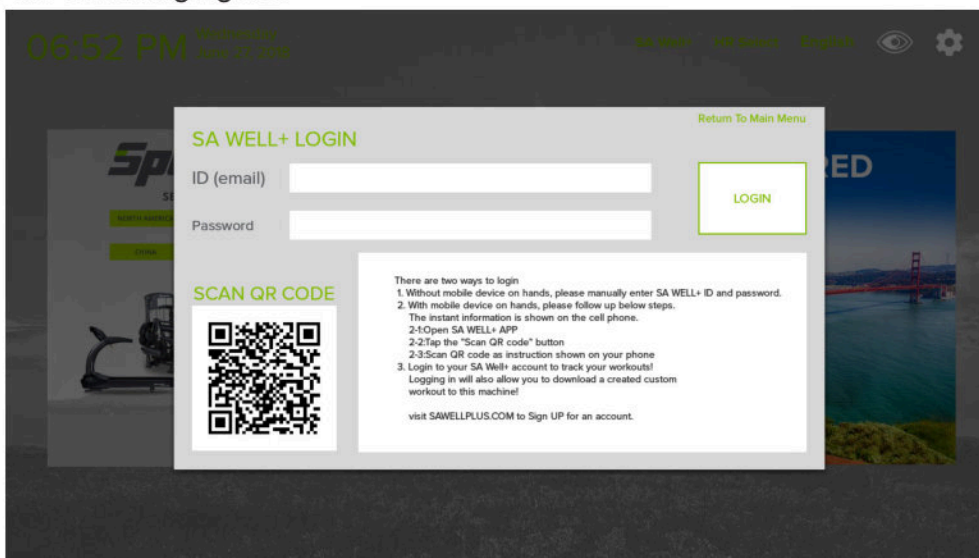

8. ABOUT HEART RATE DETECTION

Heart rate detection functions are selected at the time of purchase. Not every product has every type of heart rate detection. The following explains factors that influence the performance of two of the most common types of heart rate detection devices.

HEART RATE Telemetry

The words “telemetry heart rate” refer to the detection of heart rate via a device worn on the exerciser and transmitted over the air to a circuit board built into the product. Telemetry heart rate devices are commonly worn on the exerciser’s chest, where the pulse is strongest and relatively easy to detect.

The following explains conditions that affect the performance of the telemetry heart rate function in all products.

- Telemetry heart rate devices and the heart rate sensor belt are paired with Bluetooth.
- If the battery is too low, the receiving distance may be shortened or there will be no reception.
- Secure the heart rate sensor belt on your chest so that it stays in place without making you feel uncomfortable.
- Each fitness equipment can only be paired with one Bluetooth heart rate sensor belt. Please choose the correct Bluetooth heart rate sensor belt to prevent receiving heart rate value from exercisers appear on neighboring products.

HEART RATE Contact

The words “contact heart rate” refer to the detection of the heart rate via sensors on the product. By holding the sensors, the exerciser can view his or her heart rate on the product display. Like telemetry heart rate, contact heart rate can be influenced by several factors. The following list includes some of these factors.

- A weak pulse makes it difficult to detect heart rate.
- Low systolic blood pressure makes it difficult to detect heart rate.
- Dry, course palms impede heart rate detection. For best results, moisten your palms. But do not apply hand lotion immediately prior to your workout, because hand lotion can gum up the contact pads.

Heart rate devices built into this product are not medical devices. Heart rate values are for reference only. Do not use them for medical diagnostic or treatment work.

CAUTION: Heart rate detection and transmission devices have been known to interfere with the operation of pacemakers, possibly endangering human life. If you have a pacemaker, exercise under your doctor’s supervision; take a test to ensure your safety during the simultaneous use of the pacemaker and heart rate detection devices. The use of such devices must be undertaken at your own risk.

Note that in dry areas in particular, static electricity can interfere with unit operation and shock people. To discharge static electricity from your body, touch something else before touching metal on the product.

9. GUIDELINES FOR EXERCISE

HOW HARD SHOULD I EXERCISE?

Studies show that to benefit from aerobic exercise, people need to maintain a certain heart rate during their workouts. Your heart rate training zone depends on your age and fitness level.

The darkened area in the chart to the right represents the recommended heart rate training zone for people of various ages. It was calculated by taking 220 minus age in years, multiplied by 65% and 80%. The area between those values is the heart rate training zone.

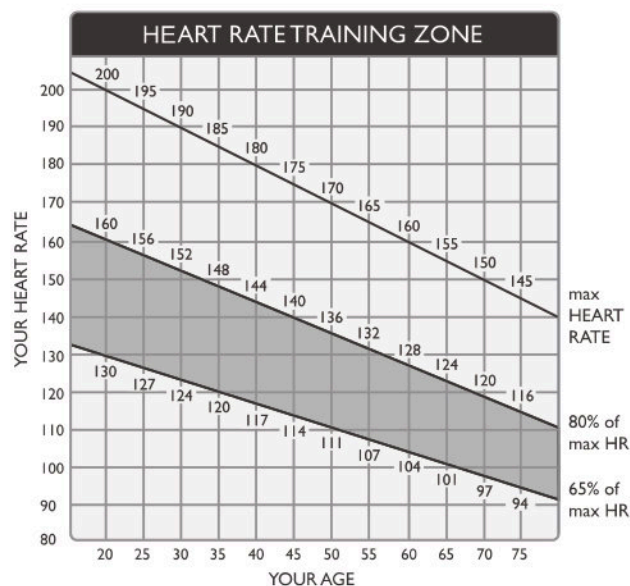

CAUTION: Heart rate training zones are generalizations and may not suit every person. Always check with your physician to understand what heart rate goal would be appropriate for you.

HOW LONG SHOULD I EXERCISE?

The duration of your workout must depend on your fitness level. In general, it is recommended that you maintain a heart rate within your training zone for at least 15 to 20 minutes to experience the benefits of aerobic exercise. Beginners should always start out slowly and gradually increase the duration and intensity of their workouts. As your fitness level improves, you will be able to maintain a heart rate within the training zone for longer periods of time.

When you begin your workout, use the first several minutes to warm up. Then slowly increase the intensity of your workout to bring your heart rate into your training zone. At the end of your workout, gradually decrease your workload. Then exercise lightly to cool down.

HOW OFTEN SHOULD I EXERCISE?

Research indicates that to achieve the greatest benefit, people should exercise three to five times per week. It is important to allow sufficient time, at least 24 hours, for your body to recover after exercise.

10. MAINTENANCE

This section covers maintenance topics, including instructions on replacing a fuse, along with the presentation of a maintenance schedule, maintenance task list, one-year maintenance log, and Wiring diagram.

MAINTENANCE Safety Precautions

- Please follow standard safety precautions when servicing on this product.
- Electronic components can carry an electrical charge even after the product has been turned off. For safety, turn off unit power. Wait five minutes to allow capacitors to discharge. Then disconnect the power cord from the wall socket (if applicable.) Only after such steps have been completed should covers be removed and electronic components accessed.
- Unplug product and wait ten minutes before performing maintenance.
- Do NOT use a damp towel to clean the product and do perform the following maintenances.
- Do NOT use cleaners with alcohol, ammonia, or other damaging chemicals. The use of such chemicals can damage the product and void the warranty. Never spray or pour any liquid directly onto the product. Doing so can damage electronic components and void the warranty.
- Use a clean, lint-free towel, dampened with a mixture of Simple Green® all-purpose cleaner, to thoroughly clean the handlebar and the console.
- This product has moving parts that can be hazardous. Exercise caution when maintaining, operating, or moving this product.
- Do not use accessories or parts that are not specifically recommended by the manufacturer (SportsArt) . Such parts might cause injuries or cause the unit to fail and void the warranty. We will not be responsible for any safety issue that arises due to the misuse of accessories or parts. At the same time, we will terminate the warranty terms of this equipment.
- The unit shall be disconnected from its power source during service and when replacing parts.
- Maintenance and repair must be performed by trained service personnel only. Improper maintenance would not only damage the machine, but also may present a danger to the exerciser.
- Keep this product out of use until maintenance is completed.
- If you need to remove the cover for repair or maintenance, be sure to contact the service station or dealer to deal with, do not operate on their own.

MAINTENANCE Error Messages

Error messages can appear on this console as a troubleshooting aid. Error messages appear in the following format: "ERROR _8_x" to represent the communication abnormality with the drive board.

Error code explanations are as follows:

ERROR_8_1_: Startup communication abnormality. Resume operation when communication is normal.

ERROR_8_2_: Startup communication is normal, however it is abnormal during operation. Resume operation when communication is normal.

Machine Model Unidentified: The machine model couldn't be identified.

MAINTENANCE Clean Schedule

If there is a need for maintenance of components, please visit the SportsArt website.

cleaning requirements

1.directive 93/42/CEE

2.directive biocide 98/8/CEE

The disinfectant has to be in compliance with Medical Device Directive 93/42/EEC (MDD) and Biocidal Products Directive 98/8/EC (BPD).

It is suited for sensitive synthetic surfaces such as synthetic leather, polycarbonate (PC), acrylic glass and polysulfone, and for the keyboards and control panels.

	Area	Day	Week	Month	Quarter	Year	Notes
1	Exterior	•					Clean.
2	Screws	•					Inspect the looseness and fix
3	Saddle	•					Clean with slightly damp wiper
4	Pedals	•					Inspect the looseness and fix.
5	Seat carriage rail		•				Apply silicone lubricant

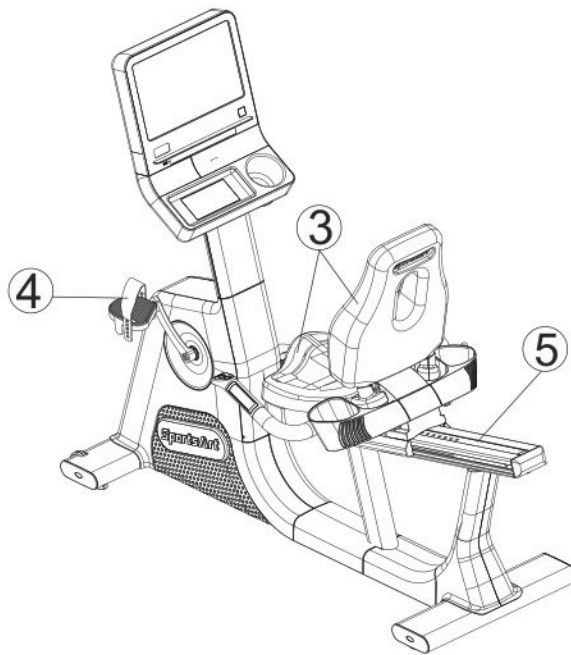

MAINTENANCE Lubrication

If the seat does not move fore and aft easily, please follow the indication as below to lubricate the seat carriage.

Push the seat forward until it stops. Add a few drops of silicone lubricant to the rear end of the sliding track on both sides, then move the seat forward and backward to allow the lubricant completely fill the entire sliding track.

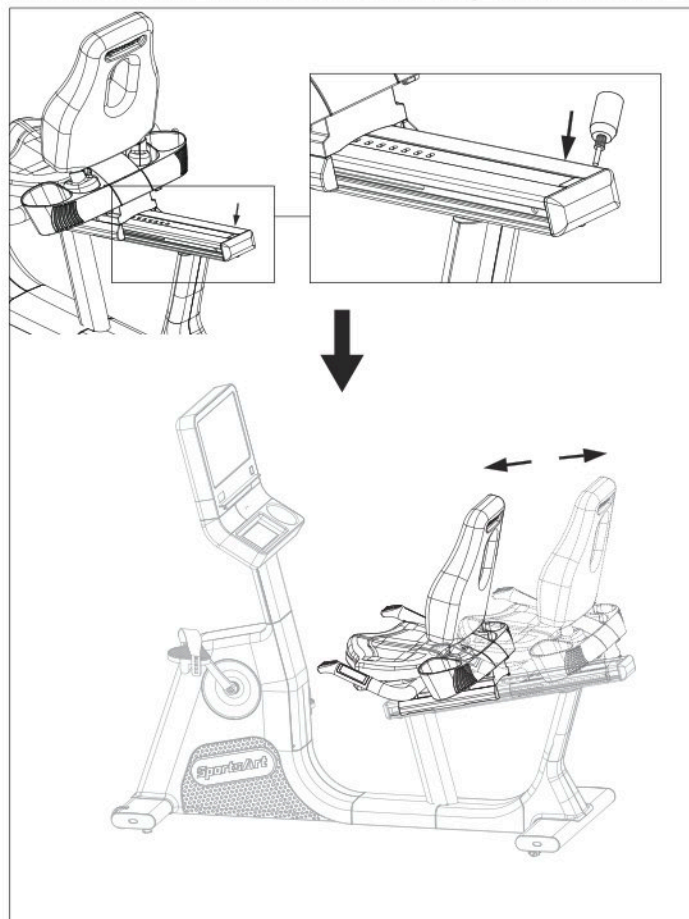

11. ACCESSORIES

ACCESSORIES Standard

USB CHARGER

1. Provides up to 5V, 1.5A of power for charging
2. Lets you update all required software drivers for the product.
3. When plugging in a USB flash drive that contains music or video files in MP3/MP4 format, the media player will be activated and the playlist will be displayed. Follow the playlist menu to control the player. (Note: This function is not available for smart phones using USB connection to play audio and video. Recommend using sandisk usb that can be compatible with the machine format [Fat32, MAX 32GB])

CSAFE PORT

Compatible with CSAFE (Communications Specification for Fitness Equipment) Protocol.

QR code and NFC tag

1. Without SA WELL+: Scanning the QR code and tapping the NFC tag will only display the SPORTSART website.
2. With SA WELL+: Using our SA WELL+ app, you can scan the QR code or tap the NFC tag on the console to connect with the product.
3. NFC tag is now only available to Android cellphone.

ACCESSORIES Option

SA WELL+ Member System

This is designed specially by SportsArt to assist the user in managing their workout history. There are three ways to get connected with the member site:

1. Using a smartphone, connect to the unit via Bluetooth/WIFI and use the SA WELL+ App. The App is available for download in the App Store and Google Play.
2. Use USB Flash Drive to store the workout data.
3. Manage user information and workout data.

Visit “www.gosportsart.com” for more information about this feature.



No.	Name of button	Function
a	USB port	This port is used for optional data transferring.
b	Bluetooth/WIFI button	When a smart phone is connected wirelessly to the unit, press this button to disconnect. Scan the QR code or tap the NFC tag on the console to connect to the equipment again.

12. APPENDIXES

APPENDIXES Specifications

Model	C574R 13"
Dimensions	L : 1725 mm (68") W : 660 mm (26") H : 1404 mm (55.2")
Overall Weight	96.5 kg (213 lbs)
Maximum User Weight	205 kg (450 lbs)
Power Requirement	100 - 120 V , 60Hz , 0.7A (USA) 200 - 240 V , 50Hz , 0.35A (EUROPE)
Circuit Breaker Current Rating	125/250Vac , 3A
Braking System	Speed-Independent

APPENDIXES Wiring Diagram

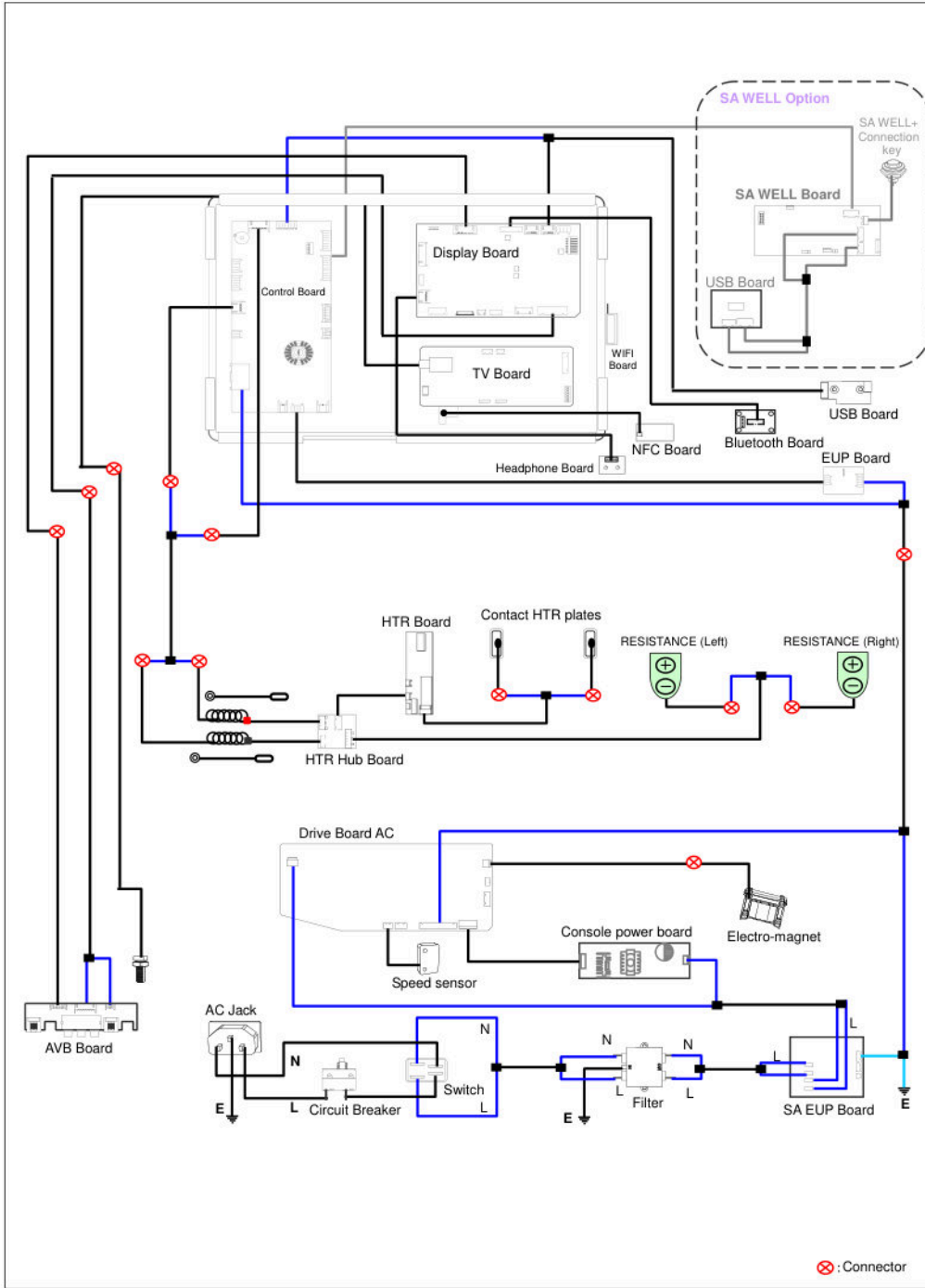

APPENDIXES **Exploded Diagrams**

Note: We reserve the right to revise the following diagrams at any time without notice to notify any person of such revisions. Please visit our official website www.gosportsart.com for the latest version.

APPENDIXES Product Disassembly

Follow sequence of index numbers 1 through 4 assigned to the figure below to disassemble the product, and be sure to remove all the retaining screws before performing disassembly.

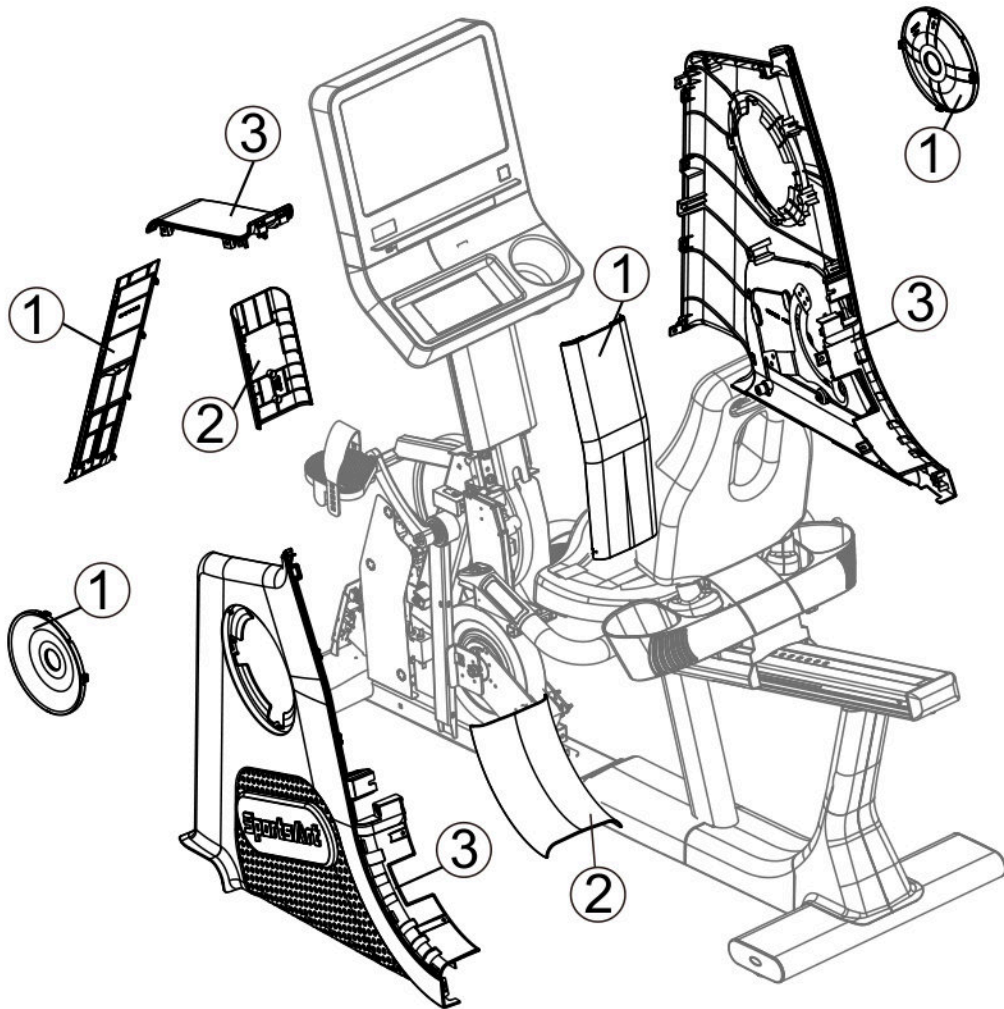

Your Authorized Distributor