

# C576U-16 OWNER'S MANUAL CONTENTS

SENZA SERIES DISCLAIMER TERMS .....	3
1. INTRODUCTION .....	4
2. SAFETY PRECAUTIONS .....	5
3. WARNING LABEL POSITION .....	7
4. LIST OF PARTS .....	8
5. ASSEMBLE THE PRODUCT .....	10
STEP 1 Install the rear support cover .....	10
STEP 2 Install the seat post .....	11
STEP 3 Install The Console and Console Mast .....	12
STEP 4 Install the Handlebar .....	13
STEP 5 Seat and Pedal .....	14
STEP 6 Install the Plastic Cover .....	15
STEP 7 Move the Bike .....	16
STEP 8 Level the Bike .....	17
STEP 9 Power Cord Assembly .....	18
STEP 10 TV and Network Function .....	19
STEP 11 Seat Fore and Aft Adjustment .....	20
STEP 12 Seat Height Adjustment .....	21
STEP 13 Essential Functions Guide .....	22
STEP 14 Power Supply Protection(Circuit Breaker) .....	23
6. UNDERSTAND THE SENZA CONSOLE .....	24
DISPLAY Overview .....	24
DISPLAY Console Panel .....	24
DISPLAY Specifications .....	25
7. OPERATE THE PRODUCT .....	26
OPERATION Safe Operating Area .....	26
OPERATION Operating position .....	27
OPERATION Step on/off the Bike .....	28
OPERATION Start Screen .....	29
OPERATION Start your (GO) Workout .....	30
OPERATION Workout Selection .....	31
OPERATION Workout Programs .....	32
OPERATION During Exercise .....	32
OPERATION Workout Status .....	33
OPERATION Select Entertainment .....	34
OPERATION View Entertainment .....	35
OPERATION Workout Summary .....	36
OPERATION Idle Mode .....	36
OPERATION Energy Smart Function .....	36
OPERATION Precautions .....	36
OPERATION SA WELL+ .....	37

## **C576U-16 OWNER'S MANUAL CONTENTS**

8. ABOUT HEART RATE DETECTION .....	38
HEART RATE Telemetry .....	38
HEART RATE Contact .....	38
9. GUIDELINES FOR EXERCISE .....	39
10. MAINTENANCE .....	40
MAINTENANCE Safety Precautions .....	40
MAINTENANCE Error Messages .....	41
MAINTENANCE Schedule .....	41
11. ACCESSORIES .....	42
ACCESSORIES Standard .....	42
ACCESSORIES Option .....	42
ACCESSORIES MYE Wireless TV Audio_Channel Receivers .....	43
12. APPENDIXES .....	44
APPENDIXES Operate the ANYcast .....	44
APPENDIXES Specifications .....	47
APPENDIXES Electronics Block Diagram .....	48
APPENDIXES Exploded Diagrams.....	49
APPENDIXES Disassembly .....	51

## SENZA SERIES DISCLAIMER TERMS

- A. Internet function:
- A1. This machine provides only a web page browsing method for web page and video browsing.
- A2. For web page videos, we support only Youku and YouTube.
- Note: Some videos may not be viewed due to restrictions resulting from country policies, internal server firewalls, or video formats, etc.
- B. IPTV:
- This function is not available yet.
- C. USB Video:
- This function is not available yet.
- D. Bluetooth functions:
- D1. Bluetooth Music (AVRCP V1.5)
- Due to the many varieties of, and rapid changes in, mobile phone models, failure of a mobile phone to connect indicates that we currently do not support that phone.
- D2. Bluetooth BLE 4.0 Heart Rate Strap
- We only support POLAR-compliant Bluetooth BLE 4.0 Heart Rate Straps.
- E. TV:
- E1. This machine only supports viewing local free TV.
- E2. This machine may be affected by the local environment, climate, equipment, etc., which may cause poor quality in reception and definition.
- F. This machine does not support the installation of third-party APPs, which may affect its operating stability.
- G. If any difference in content is found between this manual and the machine, please contact the local distributor for an electronic manual.
- H. USB charger
- Supports charging of GOOGLE-certified Android mobile phones, and Apple iPhone, iPad, iPad air, and iPad mini.
- L. CSAFE
- This function is not available yet..

# 1. INTRODUCTION

Congratulations on the purchase of a high quality SportsArt product, the C576U 16" Senza Console upright exercise cycle. Constructed of high quality materials and designed for years of reliable performance, this product was made for full commercial use.

Before this product is assembled or operated, we recommend that you familiarize yourself with this manual. Understanding the correct assembly and operation of this product will help ensure that exercisers obtain their fitness goals safely and successfully.

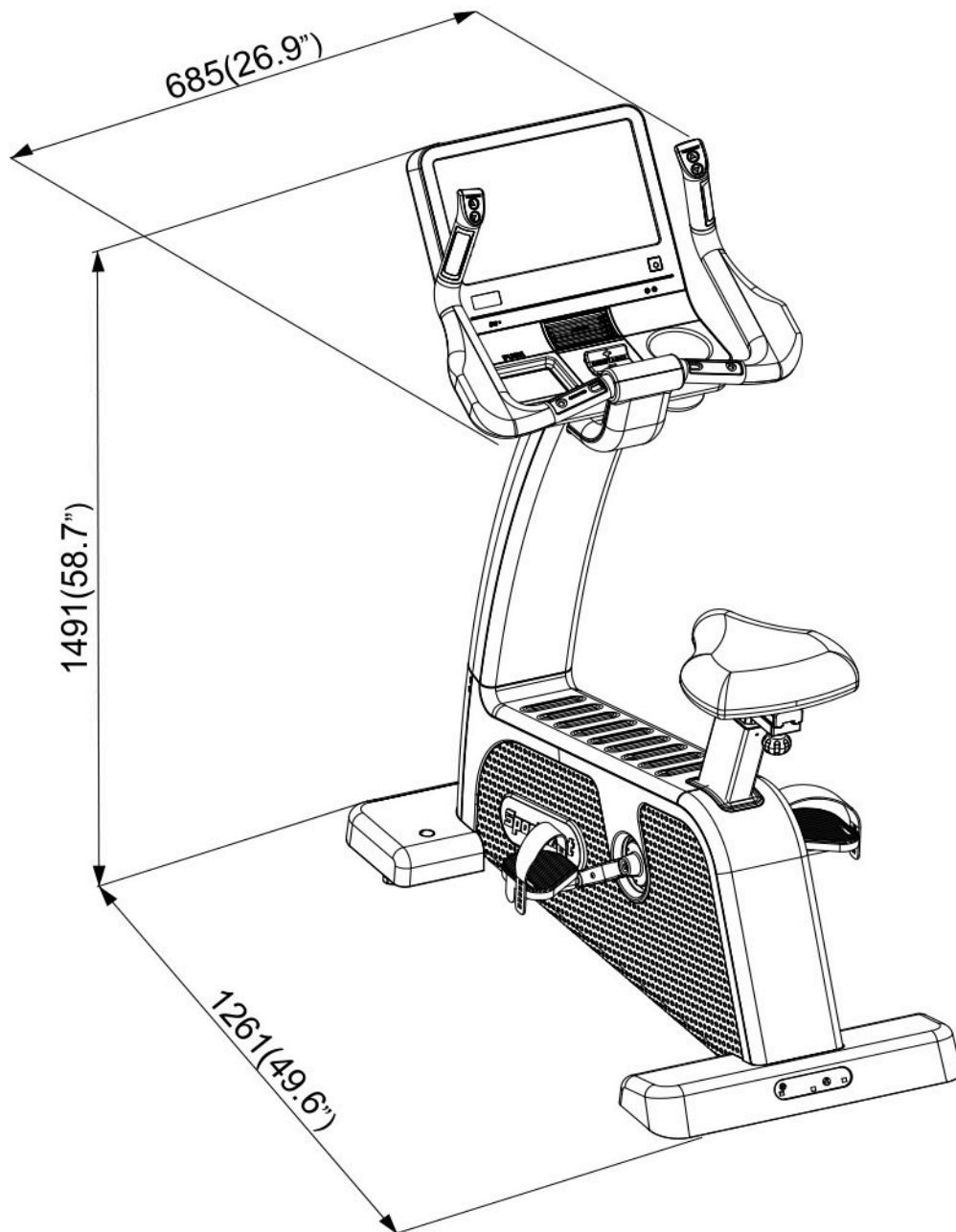

## 2. SAFETY PRECAUTIONS

Your SportsArt bike was designed and built for optimum safety. However certain precautions apply whenever you use your bike.

Please read the entire manual before assembly and operation. Also, please note the following safety precautions:

- Read instruction manual before using.
- Please read the instructions carefully and install the bike as instructed.
- Assemble and operate the bike on a solid, level surface. DO NOT use outdoors or near water.
- Do not let children 12 or younger on or near the product.
- Check the bike before every use. Make sure all parts are assembled, and all fasteners are tightened. DO NOT use the bike if the unit is disassembled in any way.
- Keep your hands away from moving parts.
- Wear proper workout clothing; DO NOT wear loose clothing. DO NOT wear shoes with leather soles or high heels. Tie all long hair back. DO NOT go barefoot on this product.
- Be careful when mounting and dismounting the unit.
- The bike may or may not stop immediately if an object becomes caught or impedes normal motion.
- Do not use accessories or parts that are not specifically recommended by the manufacturer (SportsArt). Such parts might cause injuries or cause the unit to fail and void the warranty. We will not be responsible for any safety issue that arises due to the misuse of accessories or parts. At the same time, we will terminate the warranty terms of this equipment.
- Close supervision is necessary when this bike is used by, on, or near children 12 or younger, invalids, or disabled persons.
- Use this bike only for its intended use as described in this manual.
- Never operate this bike if it has been damaged in any way. If it is not working properly, or has been dropped or damaged, contact your dealer.
- Keep all air ventilation areas free of blockage.
- Never drop or insert any object into any opening.
- DO NOT operate where aerosol (spray) products are being used or where oxygen is being administered.
- The user weight limit for this product is 227kg (500lb).  
Note that at resistance level 40 this product meets standards for users of up to 150kg (330lb).
- This bike is not intended for use by persons (including children 12 or younger ) with reduced physical, sensory or mental capabilities, or lack of experience and knowledge, unless they have been given supervision or instruction concerning use of this bike by a person responsible for their safety.

## 2. SAFETY PRECAUTIONS (CONTINUED)

- Children 12 or younger should be supervised to ensure that they do not play on or near the product.
- Maintenance and repair must be performed by trained service personnel only. Improper maintenance would not only damage the machine, but also may present a danger to the exerciser.
- Warning that any of the adjustment devices that could interfere with the user's movement should not be left projecting.
- It is not suitable for therapeutic purposes.
- **WARNING** — This stationary training equipment is not suitable for high accuracy purposes.

### Caution

If you feel any pain or abnormal sensation, **STOP YOUR WORKOUT** and consult your physician immediately. Work within your recommended exercise level. **DO NOT** work to exhaustion.

Before beginning any exercise program, you should consult with your doctor. It is recommended that you undergo a complete physical examination.

To reduce the risk of electric shock, always unplug this bike from the electrical outlet immediately after using and before cleaning. (check if power cord)

Improper connection of the equipment grounding connector can result in a risk of electric shock. Check with a qualified electrical or service person if you are in doubt as to whether the bike is properly grounded. **DO NOT** modify the plug provided with the product; if it does not fit the outlet, have the proper outlet installed by a qualified technician. (check if power cord)

Note: This equipment has been tested and found to comply with the limits for a digital device, pursuant to part 15 of the FCC Rules. These limits are designed to provide reasonable protection against harmful interference in a residential installation. This equipment generates, uses, and can radiate radio frequency energy and, if not installed and used in accordance with the instructions, may cause harmful interference to radio communications. However, there is no guarantee that interference will not occur in a particular installation. If the user desires to correct such interference, it is at the user's own expense.

### Warning

Heart rate monitoring systems may be inaccurate. Over exercise may result in serious injury or death. If you feel faint, stop exercise immediately.

### 3. WARNING LABEL POSITION

If you are in a Non-English speaking country, you can attach the warning label to the console panel as shown, otherwise, you can also stick it on a place where is clear and obvious. (please use the French version label in French-Speaking areas in North America, and the label will not be included in the other regions.)

Note: Depending on the model, the appearance of the console is different, but the labeling position is the same.

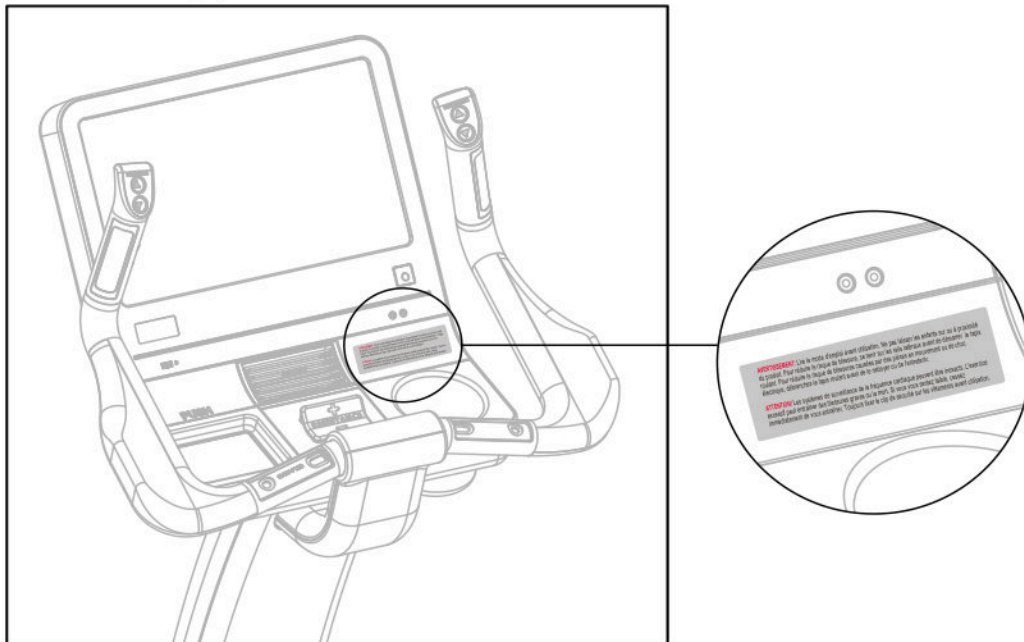

## 4. LIST OF PARTS

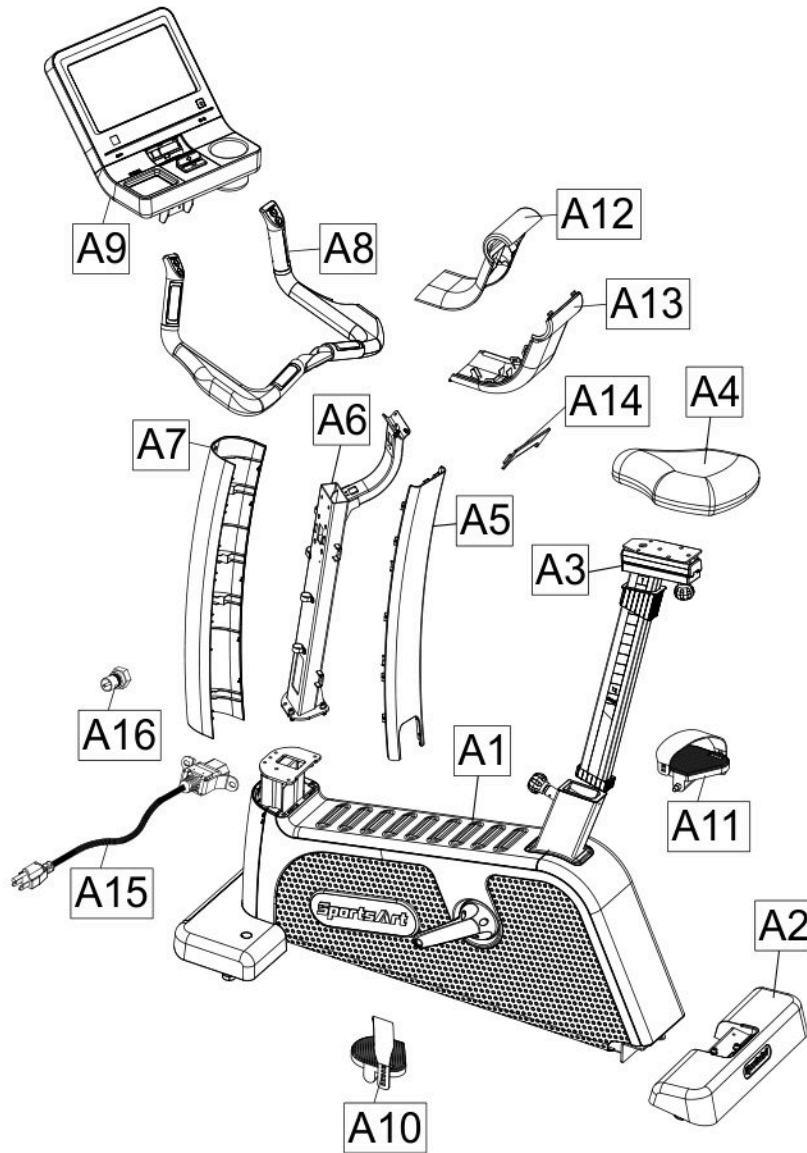

Assembly Parts					
No.	Name	Qty.	No.	Name	Qty.
A1	Main frame	1	A9	Console	1
A2	Rear Support Cover	1	A10	Left pedal	1
A3	Seat Post	1	A11	Right pedal	1
A4	Seat	1	A12	Handlebar Cover(Inside)	1
A5	Inner Pedestal Cover	1	A13	Handlebar Cover(Outside)	1
A6	Console Mast	1	A14	Console Mast Cover	1
A7	Outer Pedestal Cover	1	A15	Power cord	1
A8	Handlebar	1	A16	TV Terminal	1

## 4. LIST OF PARTS (CONTINUED)

TOOLS KIT				
No.	Name	Qty.	Specification	Notes
	T-shaped Allen Wrench	1	M6*L108	
	L-shaped Allen Wrench	1	M5*L65mm*W25	
	Two-Way Screwdriver Bit with Black Handle	1	Flat and Phillips	
	Double Open-End Wrench	1	8mm*10mm	
	Double Open-End Wrench	1	12mm*15mm	
	Double Open-End Wrench	1	13mm*15mm	

Pre-Installed Hardware			
No.	Name	Specification	Notes
21	Round head inner hex screw	M8*P1.25*L25	
	Flat Washer	D20*d8*t2.0	
	Spring Washer	M8	
22	Round head inner hex screw	M8*P1.25*L25	
	Spring Washer	M8	
	Flat Washer	D20*d8*t2.0	
23	Round head inner hex screw	M8	
24	Nylon Hex Lock Nut	M6*P1.0*H6	
	Round head inner hex screw	M6	
25	Round head inner hex screw	M6*P1.0*L20	
	Spring Washer	M6	
26	Spring Washer	M6	
	Flat Washer	D16*d6.3*t1	
	Hex Cap Screw	M6*P1.0*L15	
27	Phillips Head Screw	M4*P0.7*L8	

## 5. ASSEMBLE THE PRODUCT

### STEP 1 Install the rear support cover

Remove the cover (a) and secure the rear support cover (A2) with the pre-installed screws (21), once completed, install the cover (a) back in place and be sure it is assembled properly to the rubber gasket around the seat post.

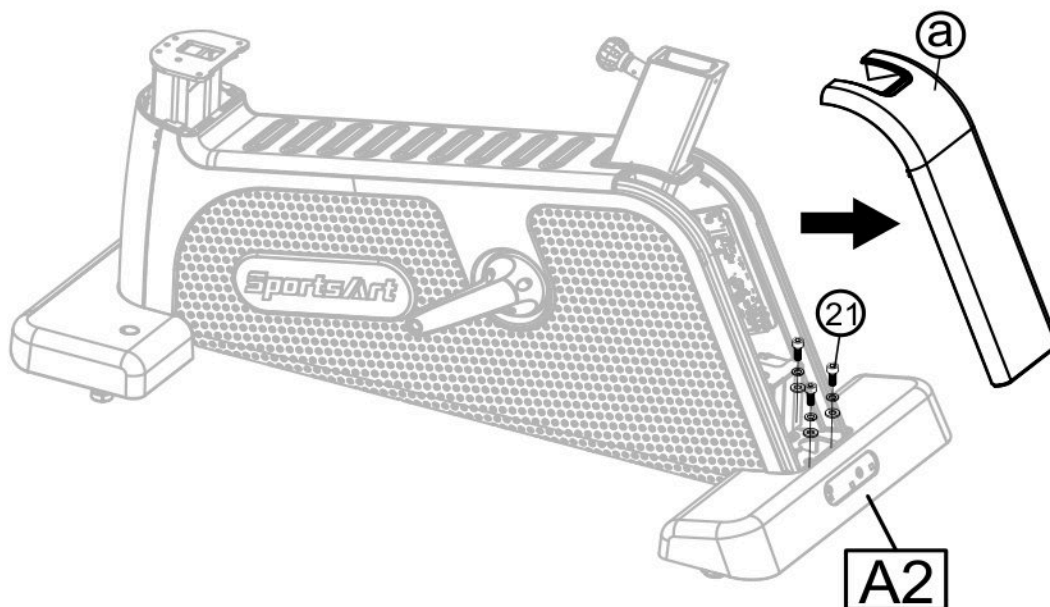

## STEP 2 Install the seat post

Pull the lock knob, and install the seat post into the seat post housing on the main frame. (A3) ( If you cannot install the seat post in place, please check if the lock knob is fully turned as shown.) Release the lock knob and install the plastic piece on the seat post to the post housing with the screws.

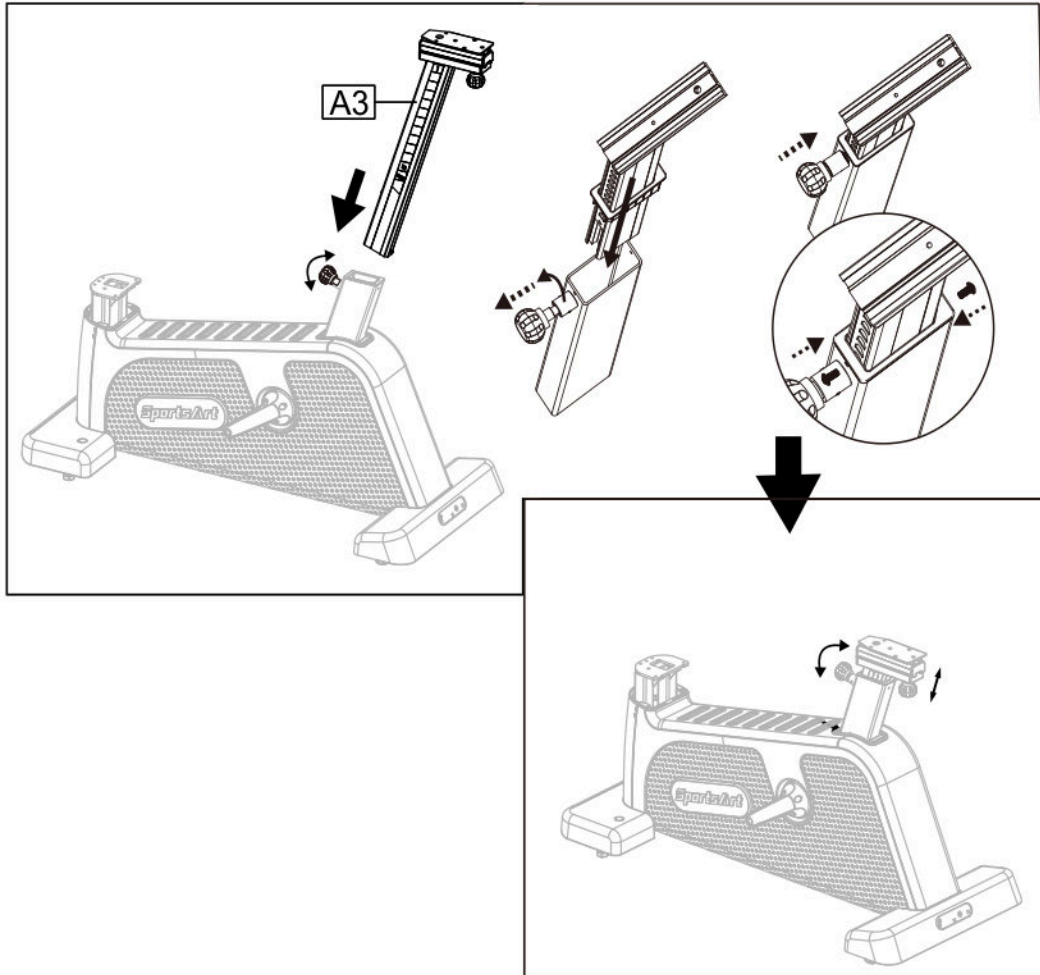

### STEP 3 Install The Console and Console Mast

- (a) Secure the console mast (A6) with the pre-installed screws (22).
- (b) Secure the console (A9) to the console mast (A6) with the pre-installed screws (23). Be careful not to pinch the power cord while assembling.
- (c) Use the feeder cord to pull the cables out from the console mast (A6) and thread them through the opening as shown, then connect to the cables of the console (A9). After connecting, place the cables back inside the console mast (A6). Once completed, please untie the feeder cord.

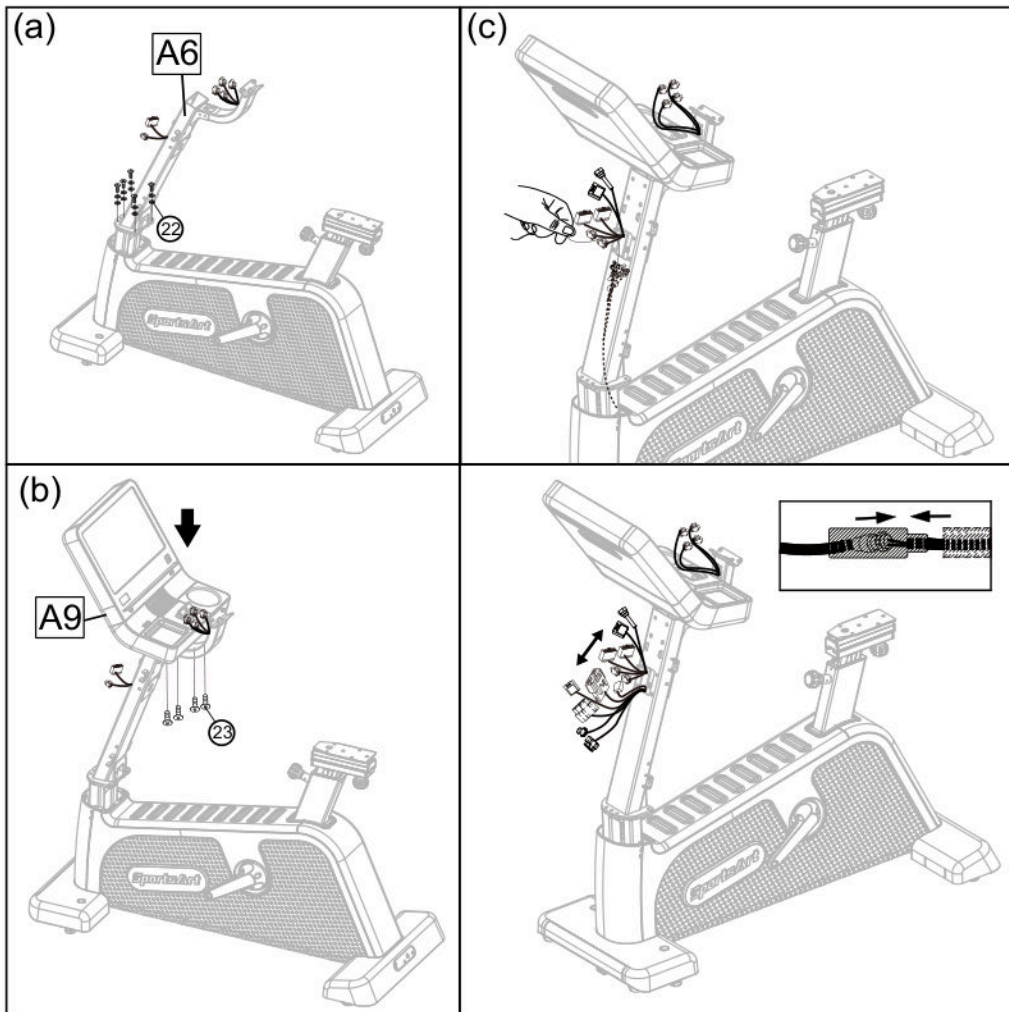

## STEP 4 Install the Handlebar

- (a) Secure the handlebar (A8) to the console mast (A6) with the pre-installed screws. (26)
- (b) Plug in the cables to the connectors on the handlebar (A8). Once completed, the cables should be arranged and placed back inside the opening as shown.

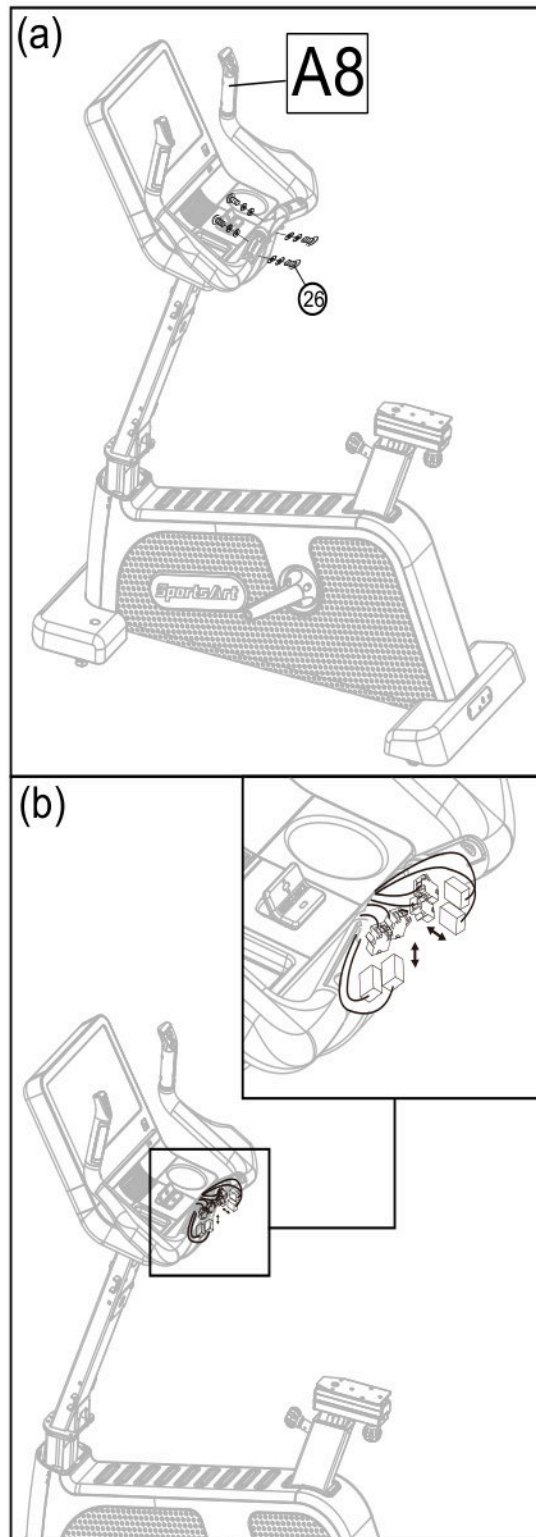

## STEP 5 Seat and Pedal

(a) Place the seat (A4) properly align to the hole on the seat post, then secure the seat with the pre-installed screws and nuts (24).

(b) Use the tool enclosed with the product to secure the left/right pedal(A10/ A11) to the crank on the main frame, please note that pedal spindle threads are different from left side and right side . DO NOT install in reverse. The tool should not be too short, otherwise, it can damage the pedals. (please use the attached wrench size in 13\*15)

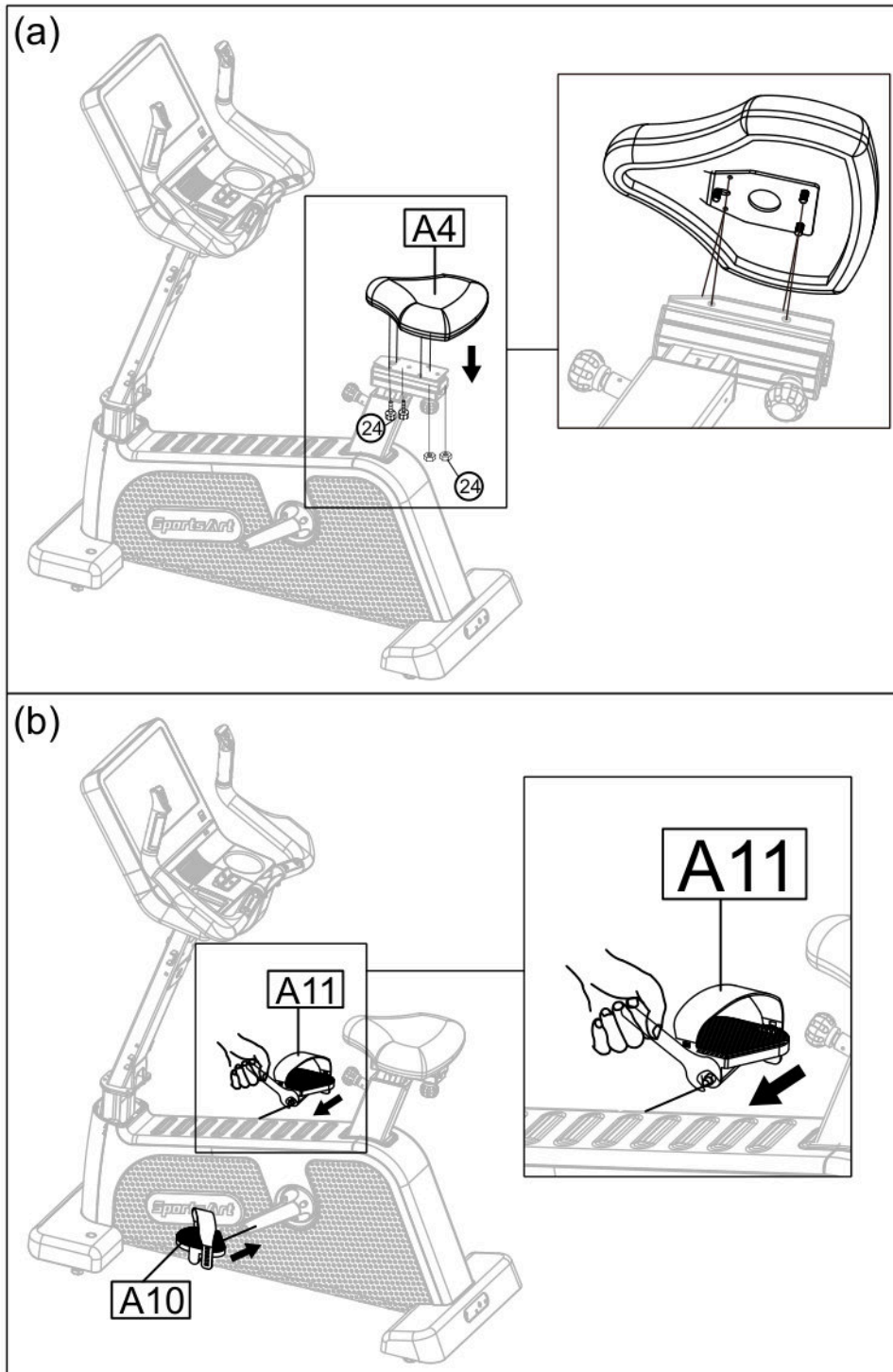

## STEP 6 Install the Plastic Cover

(a) Secure the outside cover of the handlebar (A13) with the pre-installed screws, then install the inside cover of the handlebar (A12) in place afterwards.

(b) Secure the inner pedestal cover (A5) with the pre-installed screws, then install the cover (A14) in place afterwards.

(c) Remove the lower cover first before installing the outer pedestal cover (A7) to the main frame. Please note that, the outer cover has to be pushed up first and then push down to fix it in place, when finished, install the lower cover back in place.

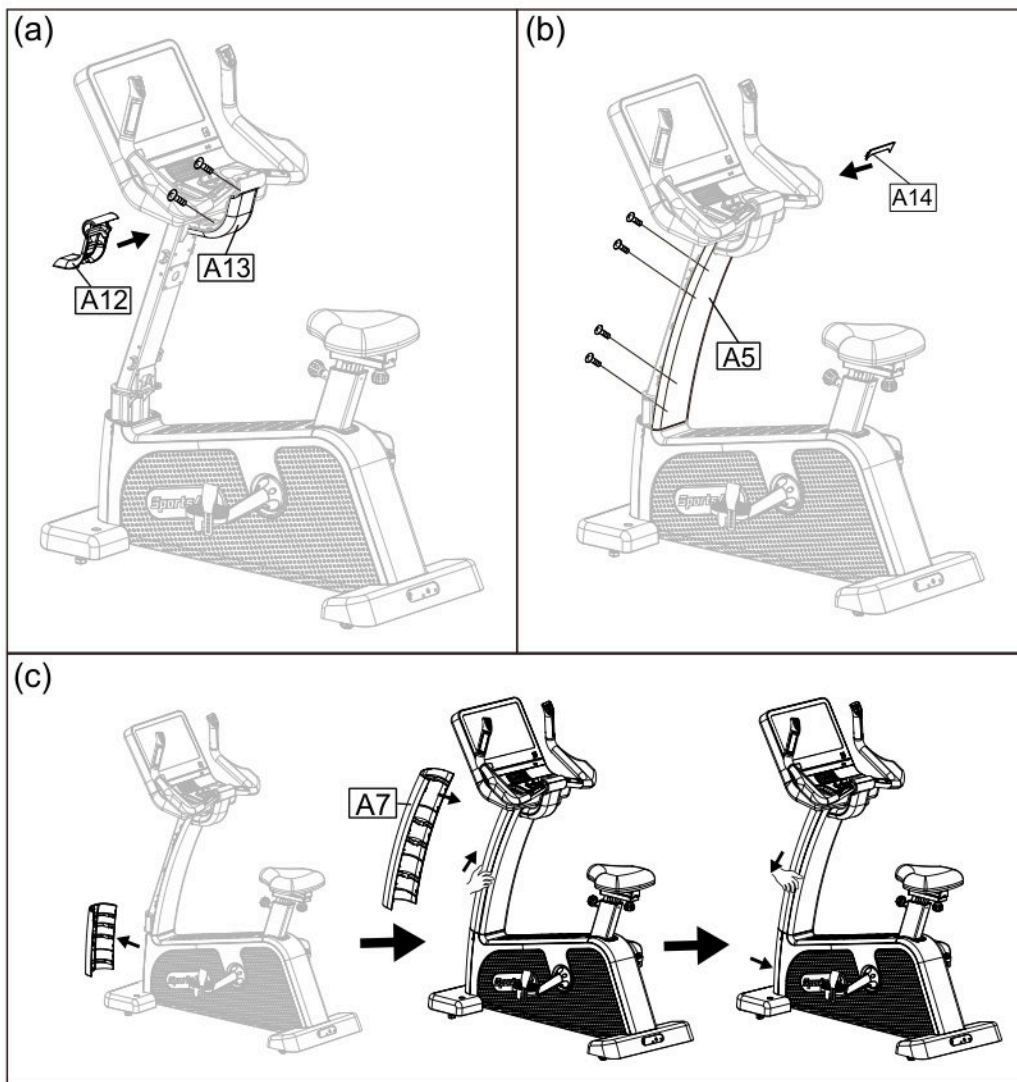

## STEP 7 Move the Bike

Please follow the instructions as below to move the bike into place for use.

(a) Please stand in front of the bike, against the front wheel with one foot, then tilt the bike for moving.

(b) Hold on the handlebar with both hands and roll it into place.

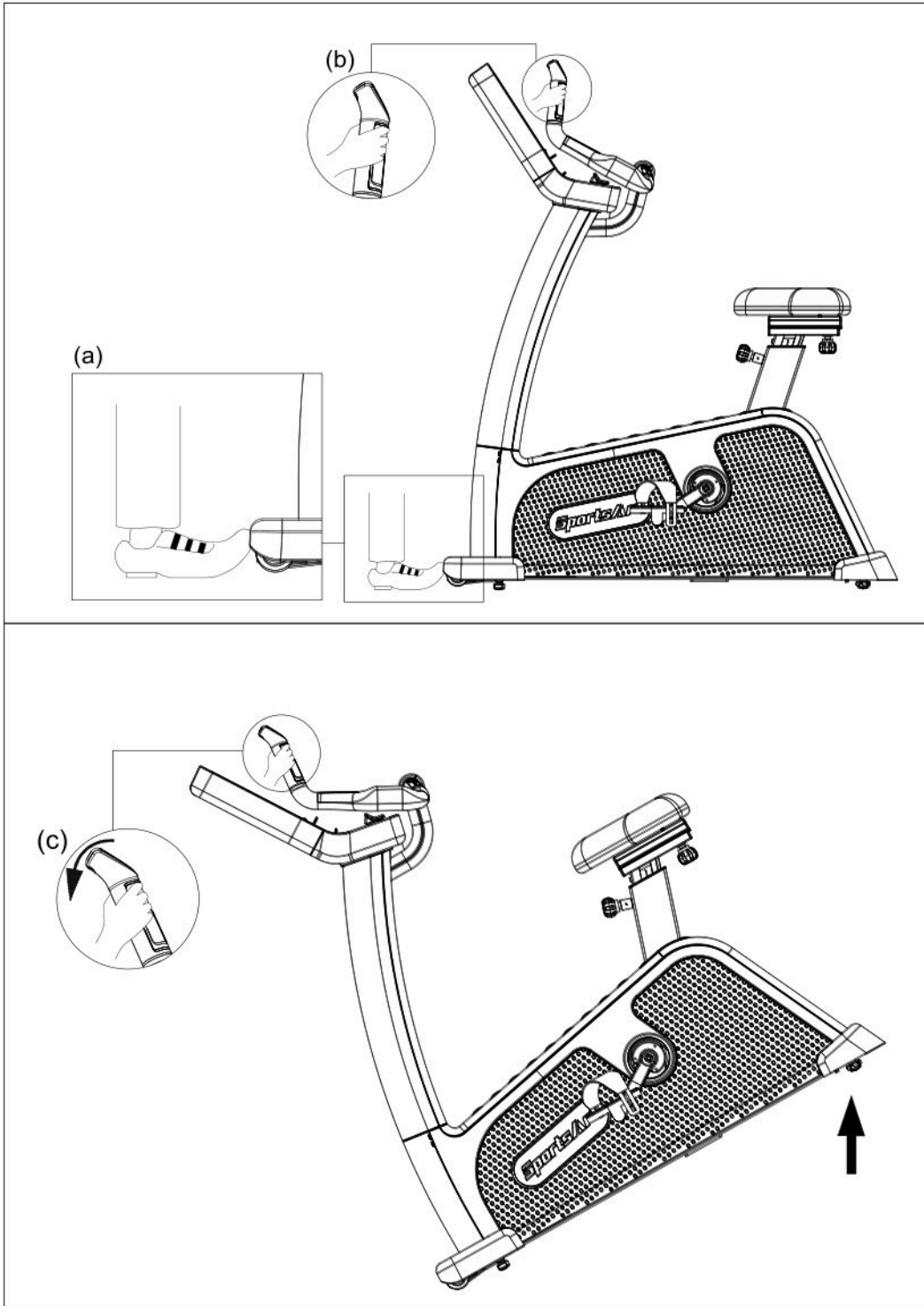

## STEP 8 Level the Bike

Please apply force to the end of the bike to check if the leveling knob is stable on the ground.

If not, adjust the levelers as follows:

- (a) Loosen the leveling knob.
  - (b) Rotate the leveling knob downward to the ground to make it steady.
  - (c) Tighten the leveling knob.
- (d) After the bike is installed and positioned, do the test operation. If necessary, make adjustment to be sure the equipment works properly.

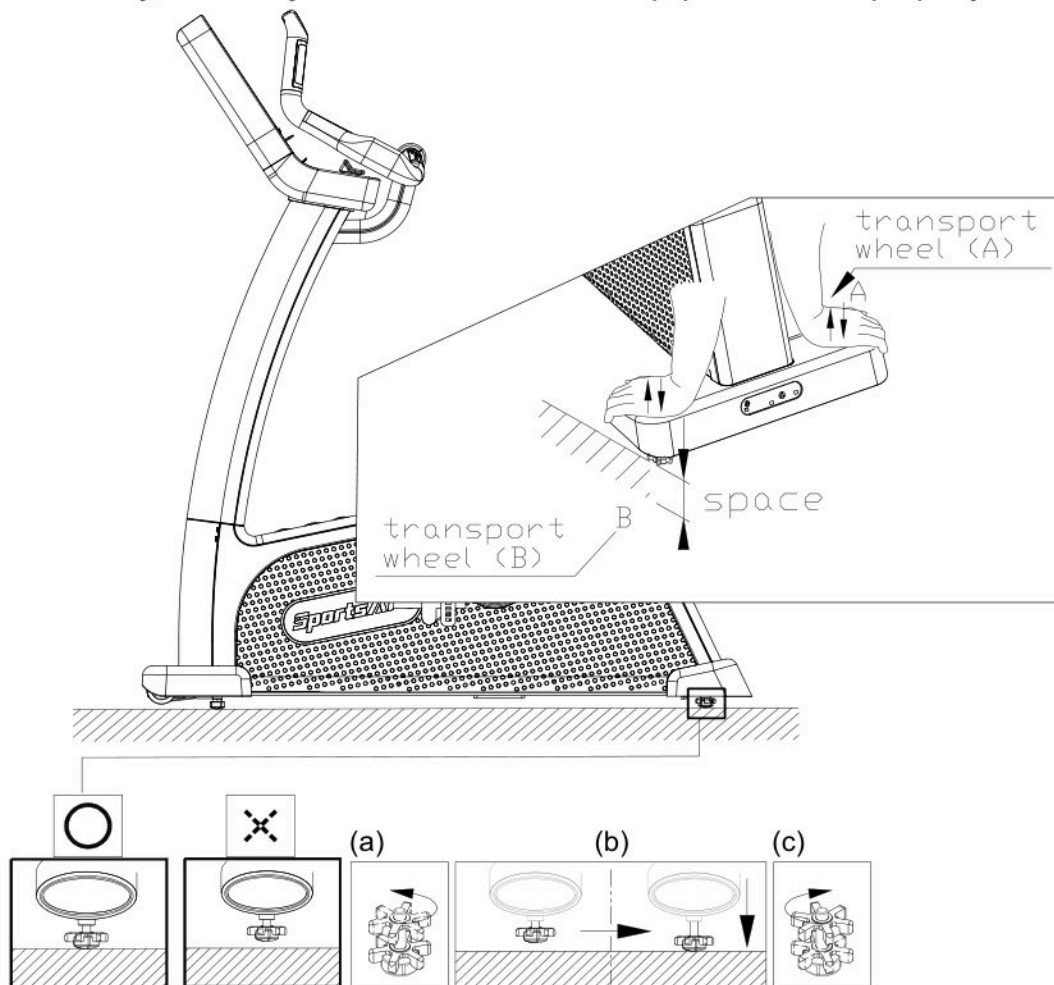

## STEP 9 Power Cord Assembly

- (1) Please remove the pre-installed screws (27) from the machine prior to assembly.
- (2) Push the plug cover of the power cord toward and against the plug.
- (3) Plug in the power cord (A15) and secure it with the screws (27).

The picture below is for your reference.

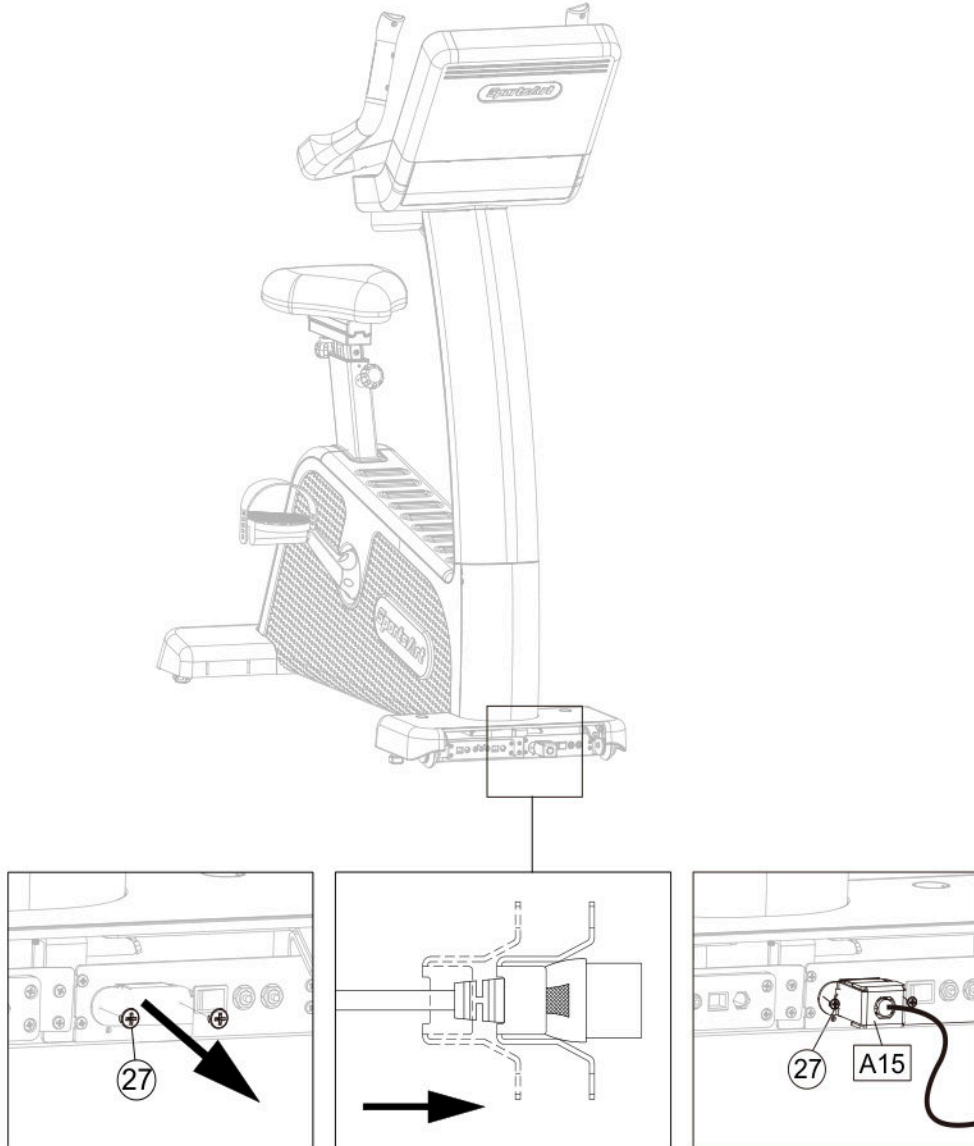

## STEP 10 TV and Network Function

- (a) NETWORK: Connect to the Ethernet with the external network signal.
- (b) AV PORT: To support external DVD PLAYER or other multimedia players using AV output signal.
- (c) To support MYE Wireless TV Audio\_Channel Receiver, and the other equipment that conform to the CSAFE specification.
- (d) TV : This machine can connect to digital TV and analog TV (for NTSC system). For PAL system, please take out the TV adapter(A16) from tools kit and connect it to TV with cables.

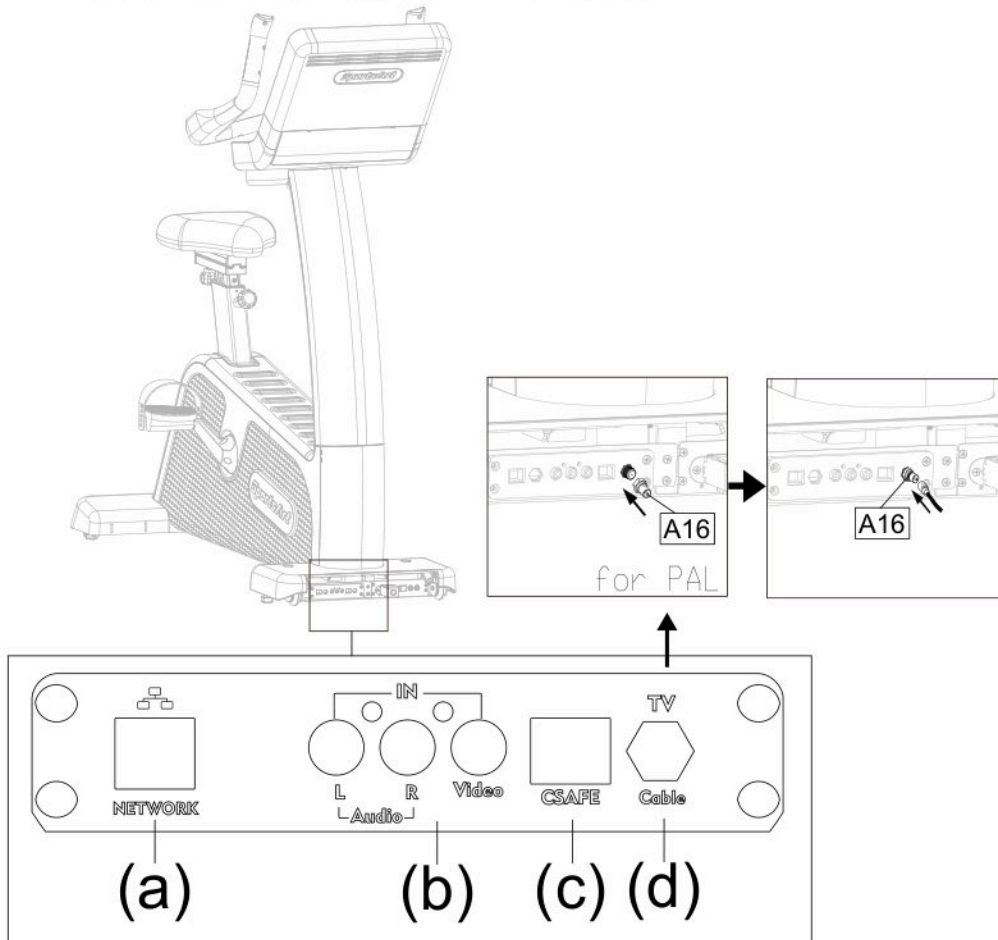

## STEP 11 Seat Fore and Aft Adjustment

- (a) Loosen the lock knob under the seat then you can move the seat easily.
- (b) Adjust the seat position by moving it forward and backward until you find the right position.

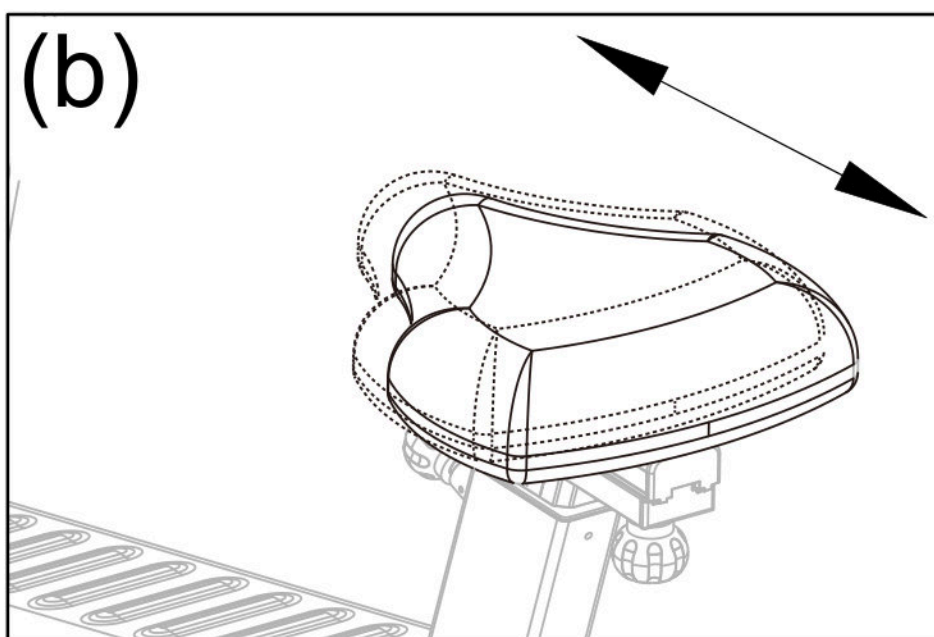
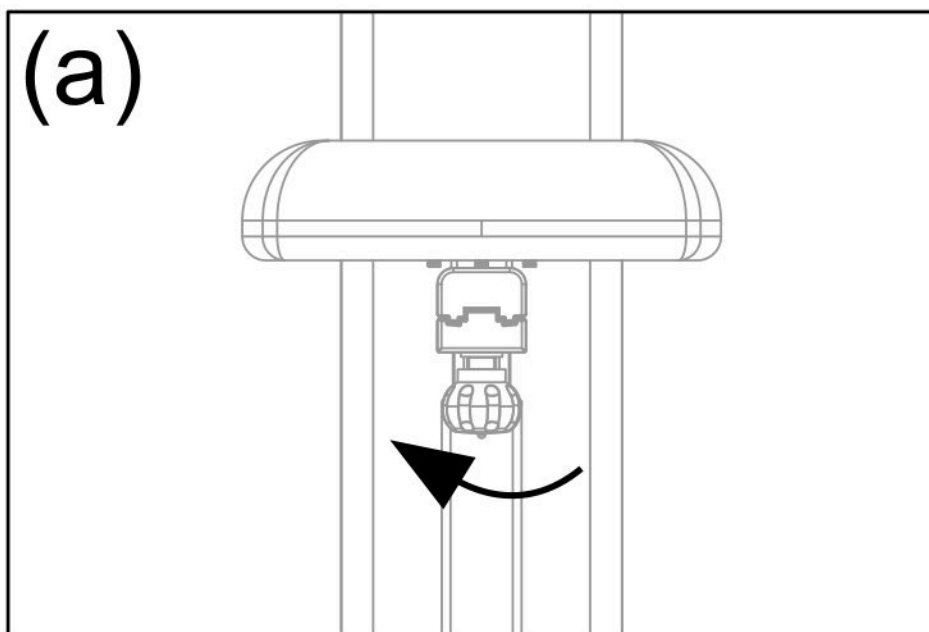

## STEP 12 Seat Height Adjustment

Loosen the lock knob in front of the seat to adjust the height. After adjustment, press the lock knob back into place and fully tighten it. to reduce the sway of the seat during use.

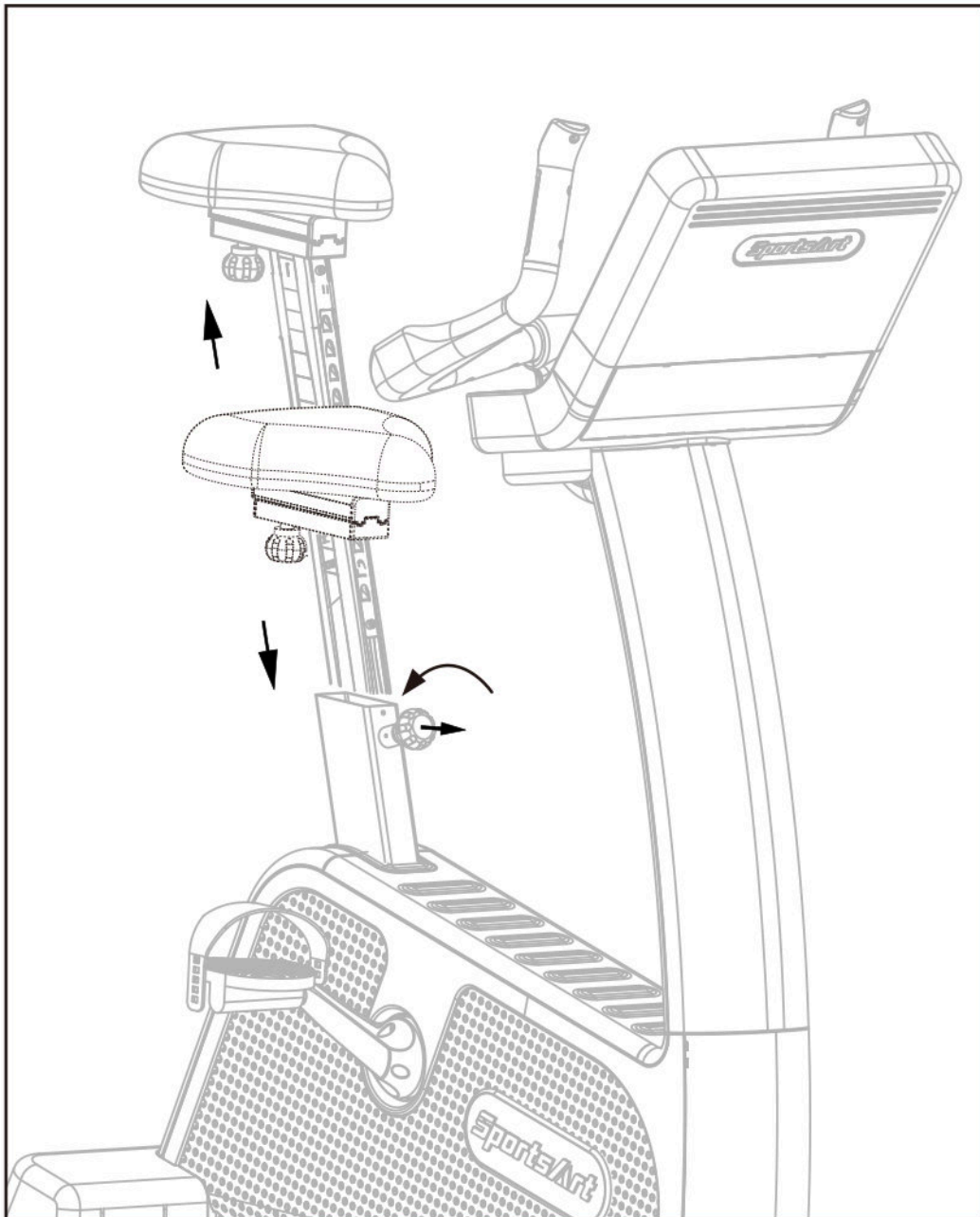

## STEP 13 Essential Functions Guide

**RESISTANCE:** Adjust the weight or force you need to place on the pedals to push them.

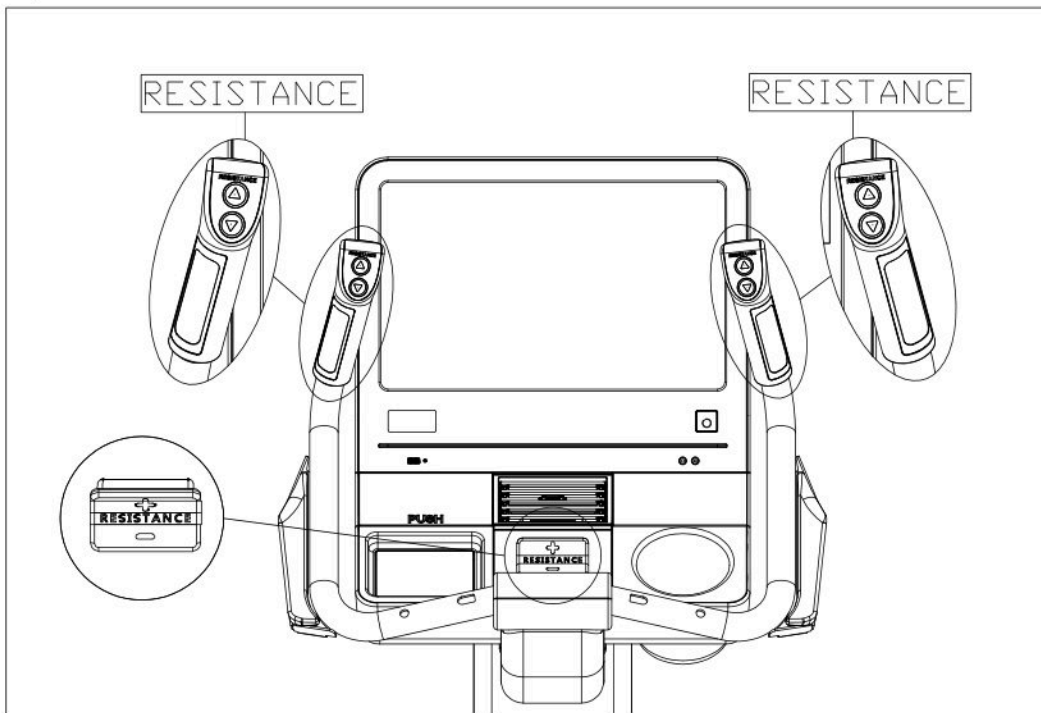

## **STEP 14** Power Supply Protection(Circuit Breaker)

When current is overloaded, the Circuit Breaker will work to protect the machine from damage. In the following picture (a) you will find a round button (D), which is the device of circuit breaker, it will pop up when current is overloaded, please turn off the machine in this situation. After the maintenance personnel find and solve the problems, press the button as shown in picture (b), then restart the machine to back on exercising.

The picture below is for your reference.

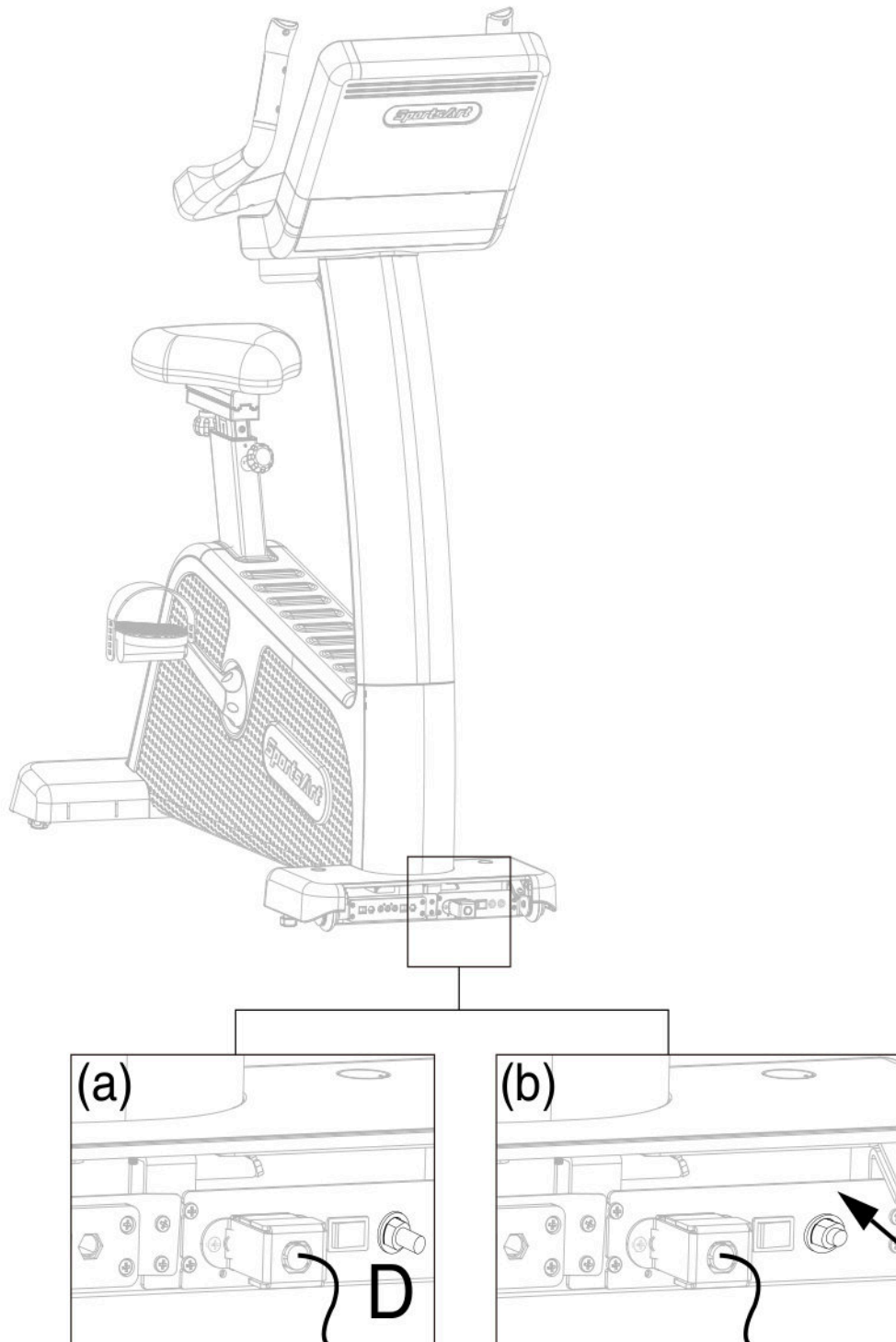

## 6. UNDERSTAND THE SENZA CONSOLE

### DISPLAY Overview

C576U Series 16" Senza Console are designed to help users obtain their fitness goals in a simple and convenient way. Before using the cycle, please familiarize yourself with the functions of this display console to obtain optimum benefits and enjoyment from this product.

### DISPLAY Console Panel



No.	Title	Function
1	QR code and NFC tag	(1) Without the SA WELL+: Only link to SPORTSART website when scanning the QR CODE and NFC label. (2) With the SA WELL+: Use the APP on your mobile scanning the QR CODE and NFC label to connect to the bike to your personal exercise records.
2	USB Port	Used for software updates but can also be used as a charging port.
3	SA WELL+ Device	Data management(This function is only available if you purchase SA WELL+)
4	RESISTANCE+ -	Press <RESISTANCE +/-> to set the resistance.
5	Wake Button	Press this key to wake-up the console panel.
6	Headphone Port	The user can listen to audio or music after inserting a headphone.

**DISPLAY Specifications**

---

<b>Parameter</b>	<b>Spec.</b>
SPEED	0.1 mph (kph)
RESISTANCE	1-40
CAL/HR	0-9999 K-CAL
TIME	0:00-600:00
DISTANCE	0.00-9999 Mile/KM
CALORIES	0-9999 K-CAL
RPM	5-150
HEART RATE	35-220 bpm

## 7. OPERATE THE PRODUCT

### OPERATION Safe Operating Area

- (a) As shown below, the area marked in diagonal lines provides the use such as normal operation, machine adjustment and any emergency. For safety, DO NOT allow people of non-users enter this area while operating.
- (b) Noise emission under load is higher than without load.

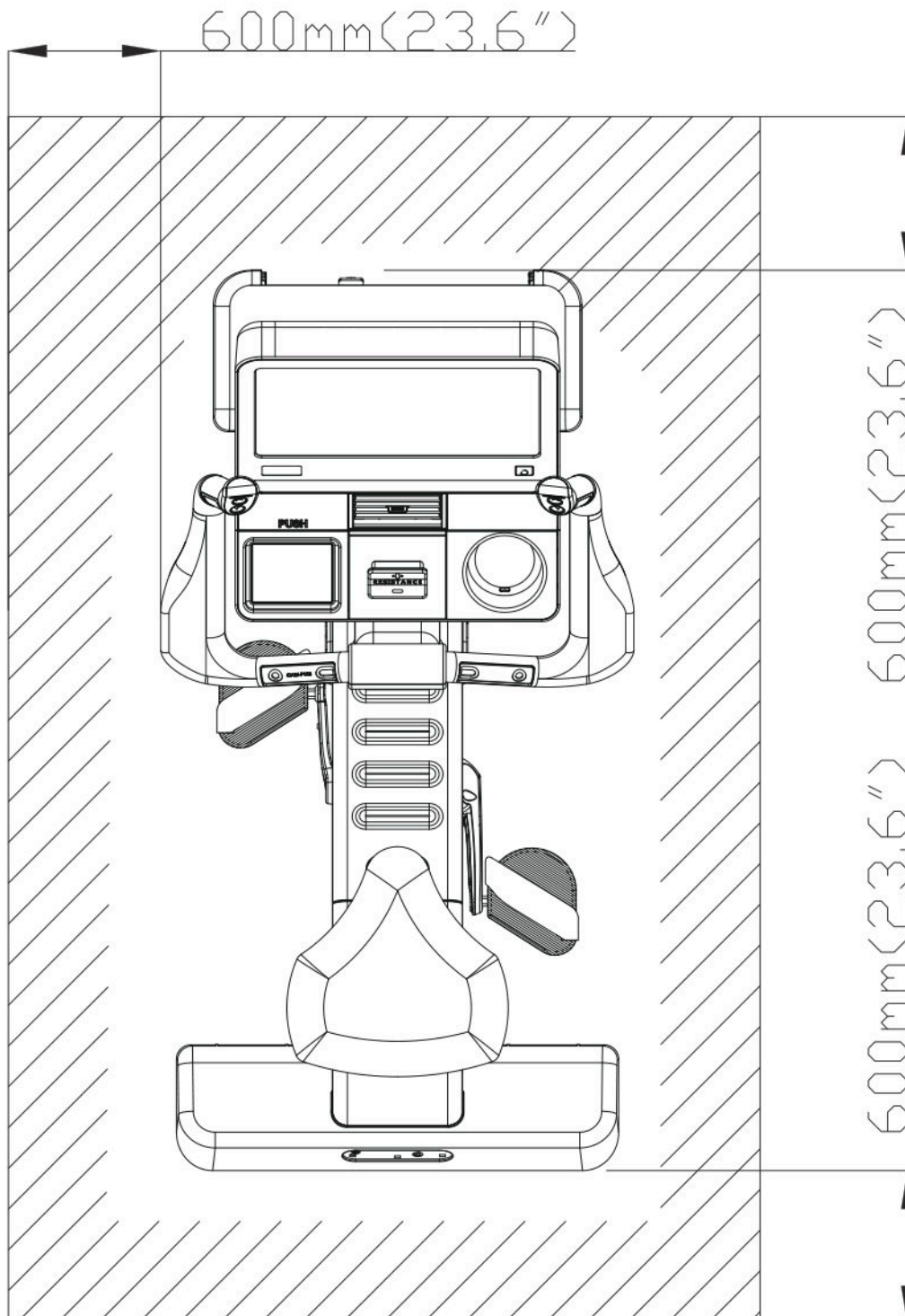

## **OPERATION** Operating position

---

- (a) Please operate the bike with proper workout position, over exercise or improper workout position may result in serious injury.
- (b) You can put your hands on the handlebar to step on/off the bike from both sides.
- (c) The machine is mainly to train the muscles on your leg.

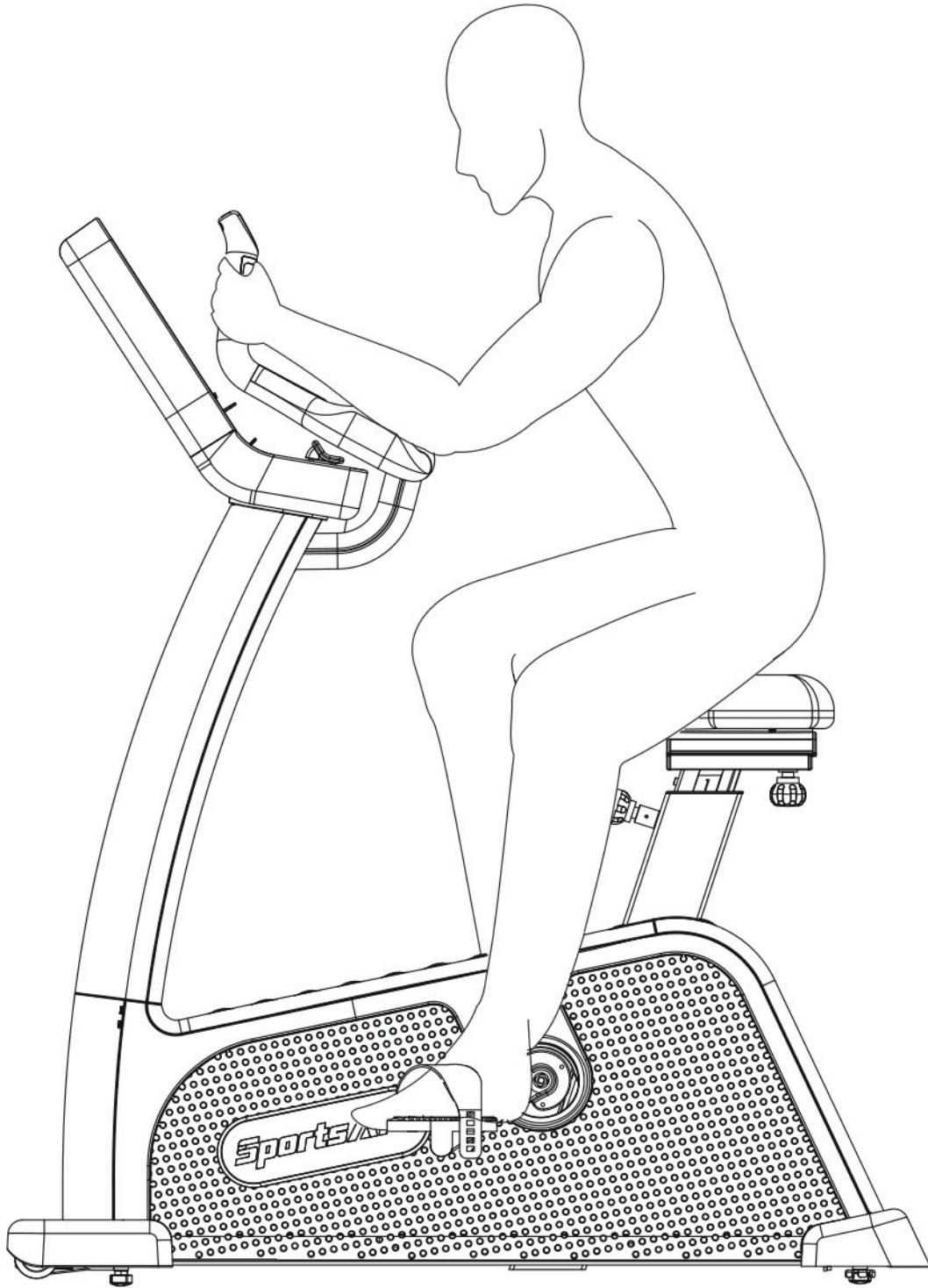

## **OPERATION** Step on/off the Bike

---

Step on the bike: Sit in the seat, hold the handlebar, put your feet on the pedals to operate the bike. (Operation position is shown as below.)

Step off the bike: Slow down your movement and leave your feet off the pedals.

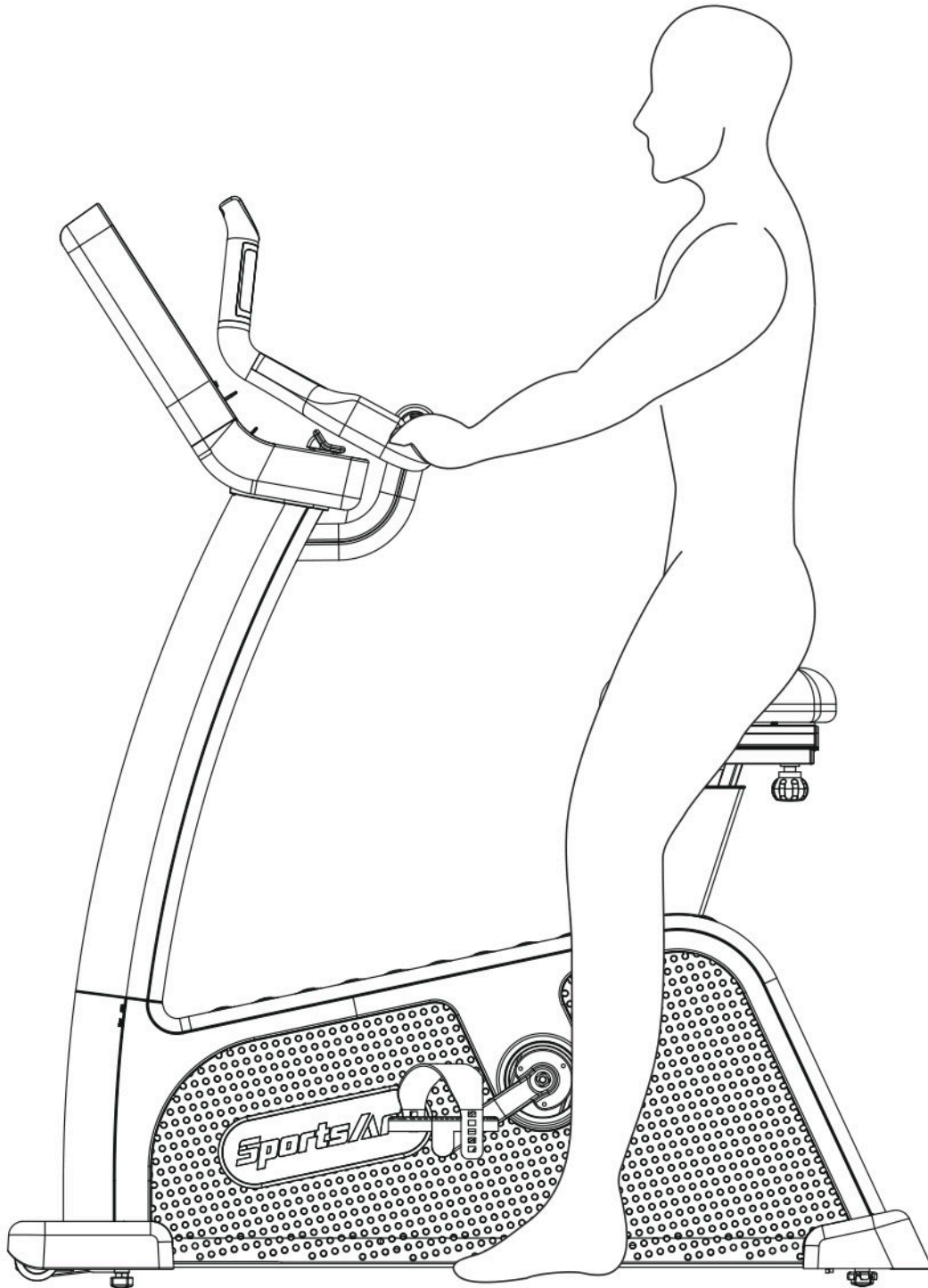

## OPERATION Start Screen

Touch screen design is simple and clear. The screen layout helps users focus on exercise. It provides many workout modes that can help you achieve your fitness goal. The following sections introduce information concerning touch screen operation, the available types of workout, and how to start the workouts.

This screen will appear when the machine is turned on.

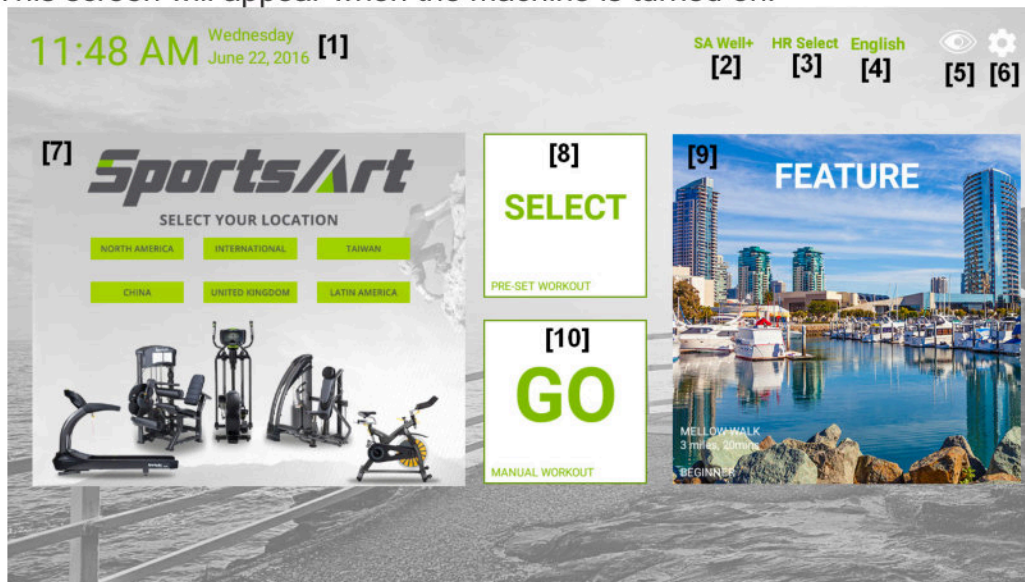

### Description of start screen buttons:

No.	Name of button	Function
1	Date and Time	Displays the current time and date
2	SA WELL+	Touch to login into the SA WELL+ system
3	HR SELECT	Touch for pairing with Bluetooth or ANT+ heart rate strap
4	LANGUAGE SETTING	Touch to select your preferred language by country
5	DISPLAY MODE	Touch to switch screen to black and white display (with high contrast). Touch again, the screen will switch back to color display
6	ENGINEERING SETTING	Touch to access the engineering mode. This is the maintenance setting for use by technicians. Password input is required to perform the actions of the related settings
7	CUSTOMIZED WEB PAGE WINDOW	Web page status display for browsing and operation
8	SELECT	Touch this button to access workout program selection
9	FEATURE	Displays various virtual realities. Touch this screen to access the virtual reality training mode
10	GO	Touch this button to start workout

## **OPERATION** Start your (GO) Workout

By using the (GO) workout, exercise is started in the manual workout mode. The default user age is 35 and default weight is 75 kg (165 lbs). You can proceed by using these default settings or change the settings.

How to start the (GO) workout:

1. Touch the (GO) button

A 3, 2, 1, GO countdown will appear on the screen, and the cycle will start.

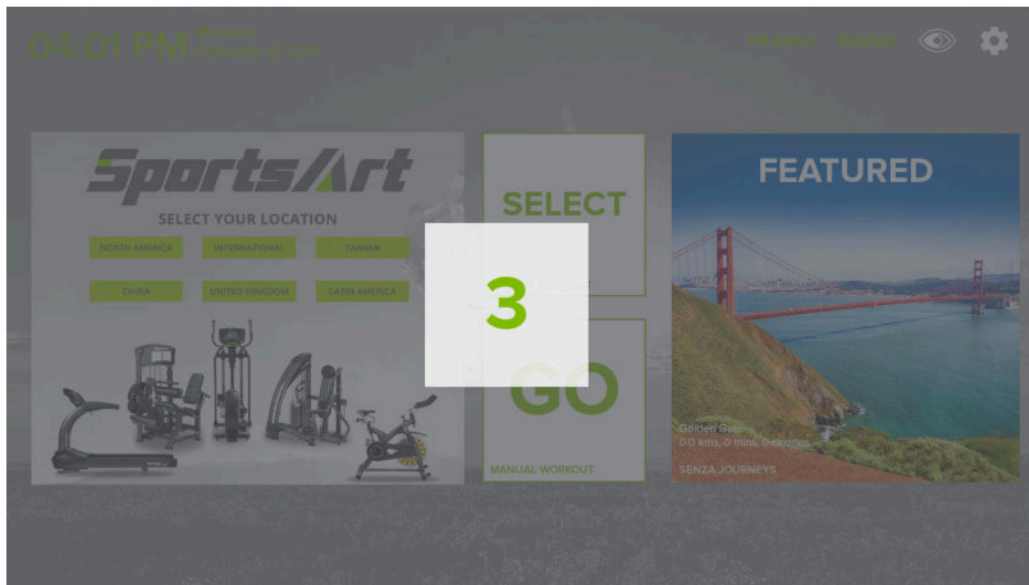

2. During the workout, if you choose to stop the workout, the “Workout Summary” screen will display the workout status for the session.

## OPERATION Workout Selection

Tap on the Select icon to access “SELECT WORKOUT”.



1. If you are pedaling, the workout will start right after a 3 second countdown timer.
2. If you are not pedaling, you can pick the option that you want.

Select workouts on the screen:

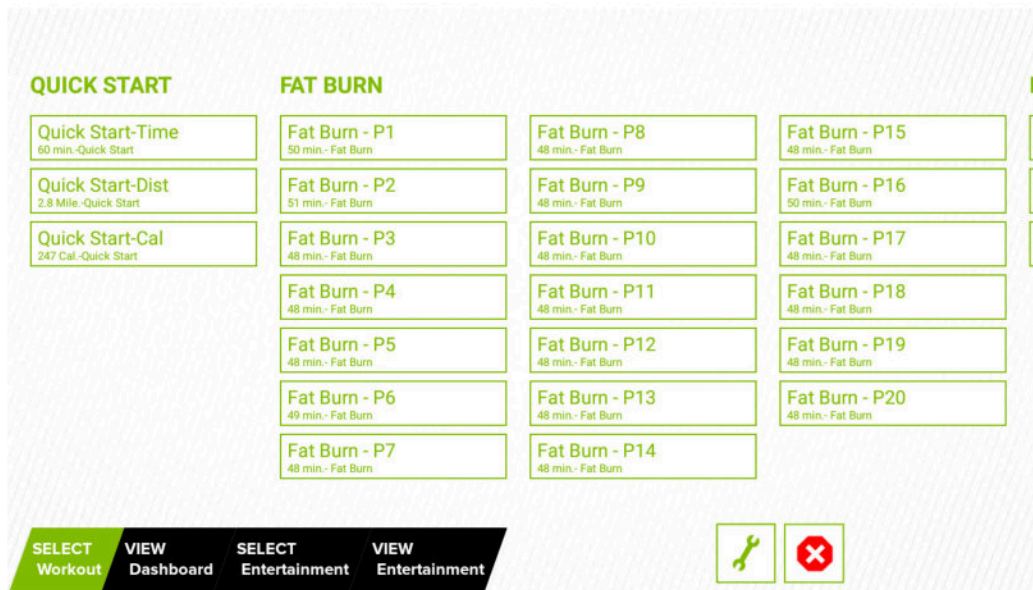
By swiping with your fingers, you can move between the workout options on the screen. The workout options are as follows: QUICK START, FAT BURN, INTERVAL, SENZA JOURNEYS , PLATEAU, WATT, HEART RATE and FITNESS TEST. You can switch among these options while exercising.



### Description of icons on the “Select” screen:

ICON	Description
	Tap to return startup screen. During exercising, tap it to stop or resume workout.
	Quick Tools

## **OPERATION** Workout Programs

---

Workout program details are explained below.

### **Quick START**

A workout mode option based on time, distance and calories that allows user to start a workout immediately.

### **FAT BURN**

Various workout mode options are provided to achieve workout goal.

### **INTERVAL (1:1, 1:2, 2:2)**

Interval Training is alternating periods of high intensity aerobic exercise and low intensity aerobic exercise.

Workout time ratios have 3 options, namely 1:1, 1:2 and 2:2.

### **SENZA JOURNEYS**

Built-in or customized landscape films allow the user to watch a video of scenery while exercising.

### **PLATEAU**

Various workout mode options are provided to achieve workout goal.

### **WATT**

Various WATT modes are provided to help you achieve workout goal.

### **HEART RATE**

A workout mode using heart rate as the target value.

### **FITNESS TEST**

A variety of professional fitness test modes are provided, including the following programs:

- YMCA

## **OPERATION** During Exercise

---

You can switch to different workout programs while exercising, with exception of the following condition:

When you use QUICK START, FAT BURN, INTERVAL, SENZA JOURNEYS, PLATEAU, HEART RATE and FITNESS TEST, you cannot switch to WATT, and vice versa.

## OPERATION Workout Status



During the workout, you can select the “VIEW Dashboard” page below the screen to check the exercise status of your workout process. There are a total of 9 status windows for various information views, and you can modify the information display format in the status windows by touching the ▼ symbol below the status windows. A drop down menu for information display format will be opened for selection.



### Drop down menu introduction:

Symbol	Drop down Menu items	
	Default	Other Options
	Resistance	Average Resistance Watts Change Resistance
	Speed	Pace Average Speed
	Time Elapsed	Time Remaining Clock Segment Duration Target Duration
	Segment Remaining	Segment Duration Time Elapsed Time Remaining
	Heart Rate	Average Heart Rate Max Heart Rate Set Target Heart Rate
	Total Distance	Distance Remaining

## OPERATION Workout Status (Continued)

Symbol	Drop down Menu items	
	Default	Other Options
	Calories	Calories/Min Calories/Hour Mets
	RPM	Average RPM

## OPERATION Select Entertainment

You can select the “Select Entertainment” page below the screen, and the available multimedia features will be displayed. The features include TV, Internet, SENZA Journeys, Bluetooth Audio, IPTV and AVIN, etc.: the small central window will display the selected multimedia screen immediately.

- Note: 1. At least 10Mbps Internet Speed is required in watching videos on YouTube or any other websites.  
 2. 10/100Mbps Base-T router is recommended for this product. If your router is 1000Mbps Base-T, ensure setting the port speed of the internet port to 10 Mbps or 100 Mbps.







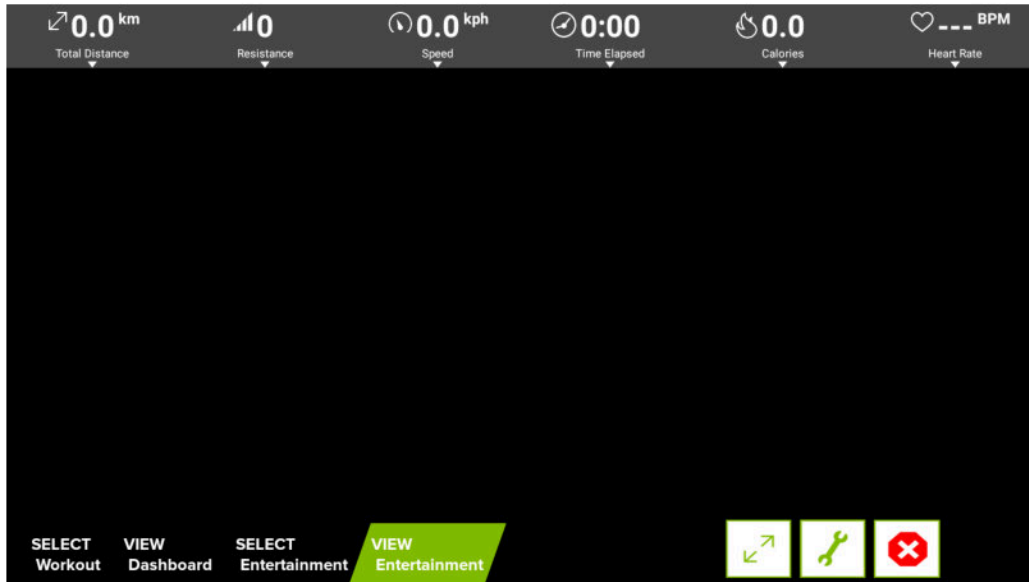

## OPERATION View Entertainment

The display mode that maximizes the selected multimedia capabilities; in addition to the multimedia display, a sidebar workout information display is also included, so the user can check their current workout status instantly while using the multimedia features.



Description of icons in the “Entertainment” screen:

ICON	Description
	Full Screen (Exit full screen mode by tapping screen.)
	Mute
	Lower volume
	Raise volume
	Slow reverse
	Play
	Fast Forward

## **OPERATION** Workout Summary

At the end of a workout or when you press the stop button, the workout summary screen will appear. The screen shows your current workout status.



## **OPERATION** Idle Mode

When the cycle stops running with no other activity for 2 minutes, the machine will enter the idle mode and the display will randomly show the standby picture. Touch any position in the idle mode to enter the Home page.

**Note:** The standby picture can be changed and set by the user.

## **OPERATION** Energy Smart Function

There is a default Energy Smart timer setting feature in the engineering mode. When the cycle is not in use and the set up time for power saving is reached, the system will automatically enter the power saving mode, the Energy SMART light will change from green to orange, and the whole screen will turn dark. Press the Wake Up button to turn the power back on.

## **OPERATION** Precautions

1. Turning the product on and off every day will make your software system refresh and stable. Please wait 5 minutes before turning the product back on when restarting.
2. SanDisk USB (Fat32, MAX 32GB) is recommended for updating the program.

## OPERATION SA WELL+

Tap SA WELL+ to enter SA WELL+ Login page.

First time user must create a user account with SA WELL+ App. After sign up, user information will be saved into the account.

Login to your SA Well+ account to track your workouts and will also allow you to download a created custom workout to machine.

There are two ways to login:

1. Without mobile device on hands, please manually enter SA WELL+ ID and password.
2. With mobile device on hands, please follow up below steps.  
The instant information is shown on the cell phone.
  - 2-1. Open SA WELL+ APP
  - 2-2. Tap the "Scan QR code" button
  - 2-3. Scan QR code as instruction shown on your phone.

If your equipment is not equipped with SA WELL+, Login page will be shown as the following figure.

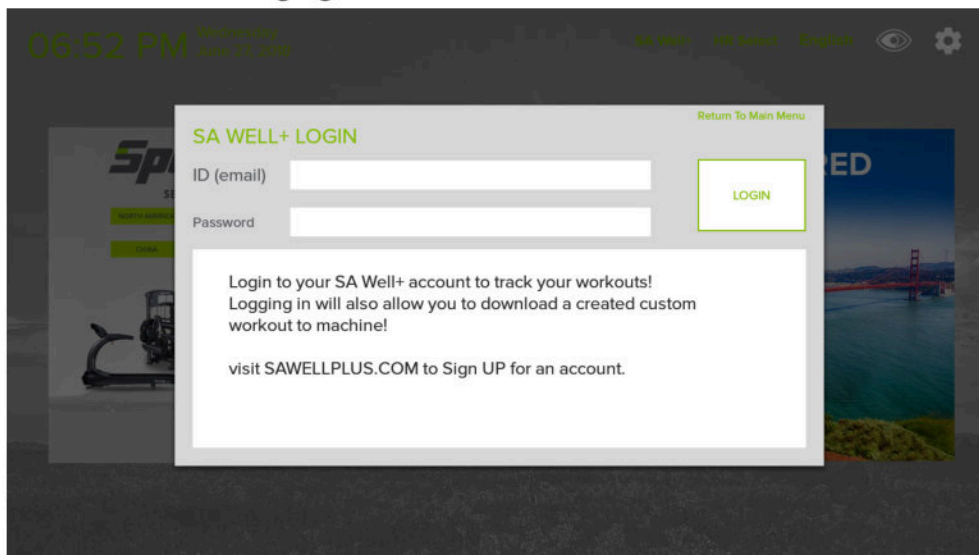

If your equipment is equipped with SA WELL+, Login page will be shown as the following figure.

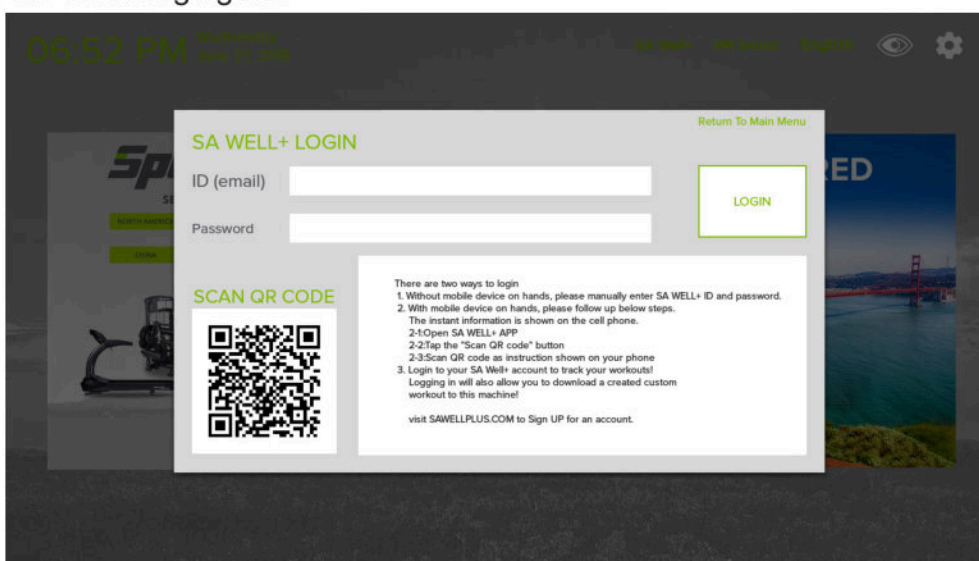

## 8. ABOUT HEART RATE DETECTION

Heart rate detection functions are selected at the time of purchase. Not every product has every type of heart rate detection. The following explains factors that influence the performance of two of the most common types of heart rate detection devices.

### HEART RATE Telemetry

---

The words “telemetry heart rate” refer to the detection of heart rate via a device worn on the exerciser and transmitted over the air to a circuit board built into the product. Telemetry heart rate devices are commonly worn on the exerciser’s chest, where the pulse is strongest and relatively easy to detect.

The following explains conditions that affect the performance of the telemetry heart rate function in all products.

- The telemetry heart rate transmitter emits a wireless 5 kHz signal that is harmless to the human body. Keep a distance within 60cm between the heart rate receptor and the transmitter to achieve stable connection.
- If the battery is too low, the receiving distance may be shortened or there will be no reception.
- Secure the telemetry heart rate transmitter on your chest so that it stays in place without making you feel uncomfortable. Moisten the skin for better contact.
- Because the telemetry heart rate signal varies in strength from 20 Hz to 20 KHz, environmental interference can block signal reception. Physical vibration and electronic devices, including stereos, TVs, and even fluorescent lights, can interfere with signal reception. For best results, install the product in an area free from such interference.
- Space the product apart by at least 39 inches (100 cm) to avoid having the heart rate value from one exerciser appear on a neighboring product.

### HEART RATE Contact

---

The words “contact heart rate” refer to the detection of the heart rate via sensors on the product. By holding the sensors, the exerciser can view his or her heart rate on the product display. Like telemetry heart rate, contact heart rate can be influenced by several factors. The following list includes some of these factors.

- A weak pulse makes it difficult to detect heart rate.
- Low systolic blood pressure makes it difficult to detect heart rate.
- Dry, course palms impede heart rate detection. For best results, moisten your palms. But do not apply hand lotion immediately prior to your workout, because hand lotion can gum up the contact pads.

Heart rate devices built into this product are not medical devices. Heart rate values are for reference only. Do not use them for medical diagnostic or treatment work.

**CAUTION:** Heart rate detection and transmission devices have been known to interfere with the operation of pacemakers, possibly endangering human life. If you have a pacemaker, exercise under your doctor’s supervision; take a test to ensure your safety during the simultaneous use of the pacemaker and heart rate detection devices. The use of such devices must be undertaken at your own risk.

Note that in dry areas in particular, static electricity can interfere with unit operation and shock people. To discharge static electricity from your body, touch something else before touching metal on the product.

## 9. GUIDELINES FOR EXERCISE

### HOW HARD SHOULD I EXERCISE?

Studies show that to benefit from aerobic exercise, people need to maintain a certain heart rate during their workouts. Your heart rate training zone depends on your age and fitness level.

The darkened area in the chart to the right represents the recommended heart rate training zone for people of various ages. It was calculated by taking 220 minus age in years, multiplied by 65% and 80%. The area between those values is the heart rate training zone.

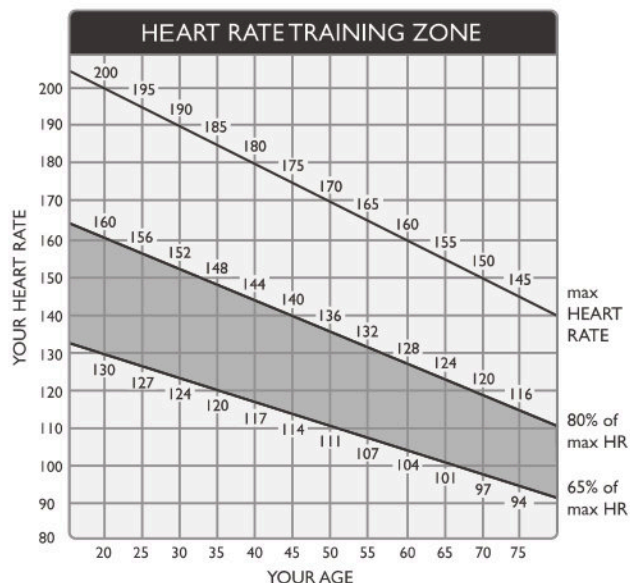

**CAUTION:** Heart rate training zones are generalizations and may not suit every person. Always check with your physician to understand what heart rate goal would be appropriate for you.

### HOW LONG SHOULD I EXERCISE?

The duration of your workout must depend on your fitness level. In general, it is recommended that you maintain a heart rate within your training zone for at least 15 to 20 minutes to experience the benefits of aerobic exercise. Beginners should always start out slowly and gradually increase the duration and intensity of their workouts. As your fitness level improves, you will be able to maintain a heart rate within the training zone for longer periods of time.

When you begin your workout, use the first several minutes to warm up. Then slowly increase the intensity of your workout to bring your heart rate into your training zone. At the end of your workout, gradually decrease your workload. Then exercise lightly to cool down.

### HOW OFTEN SHOULD I EXERCISE?

Research indicates that to achieve the greatest benefit, people should exercise three to five times per week. It is important to allow sufficient time, at least 24 hours, for your body to recover after exercise.

## 10. MAINTENANCE

This section covers maintenance topics, including instructions on replacing a fuse and lubricating the walk belt, along with the presentation of a maintenance schedule, maintenance task list, one-year maintenance log, and electronics block diagram.

### **MAINTENANCE** Safety Precautions

- Please follow standard safety precautions when servicing on this product.
- Electronic components can carry an electrical charge even after the product has been turned off. For safety, turn off unit power. Wait five minutes to allow capacitors to discharge. Then disconnect the power cord from the wall socket (if applicable.) Only after such steps have been completed should covers be removed and electronic components accessed.
- Unplug product and wait ten minutes before performing maintenance.
- Do NOT use a damp towel to clean the product and do perform the following maintenances.
- Do NOT use cleaners with alcohol, ammonia, or other damaging chemicals. The use of such chemicals can damage the product and void the warranty. Never spray or pour any liquid directly onto the product. Doing so can damage electronic components and void the warranty.
- Use a clean, lint-free towel, dampened with a mixture of Simple Green® all-purpose cleaner, to thoroughly clean the handlebar and the console.
- This product has moving parts that can be hazardous. Exercise caution when maintaining, operating, or moving this product.
- Do not use accessories or parts that are not specifically recommended by the manufacturer (SportsArt) . Such parts might cause injuries or cause the unit to fail and void the warranty. We will not be responsible for any safety issue that arises due to the misuse of accessories or parts. At the same time, we will terminate the warranty terms of this equipment.
- The treadmill shall be disconnected from its power source during service and when replacing parts.
- Maintenance and repair must be performed by trained service personnel only. Improper maintenance would not only damage the machine, but also may present a danger to the exerciser.
- Keep this product out of use until maintenance is completed.
- If you need to remove the cover for repair or maintenance, be sure to contact the service station or dealer to deal with, do not operate on their own.

## **MAINTENANCE** Error Messages

Error messages can appear on this console as a troubleshooting aid. Error messages appear in the following format: "ERROR \_8\_x" to represent the communication abnormality with the drive board.

Error code explanations are as follows:

ERROR\_8\_1\_: Startup communication abnormality. Resume operation when communication is normal.

ERROR\_8\_2\_: Startup communication is normal, however it is abnormal during operation. Resume operation when communication is normal.

Machine Model Unidentified: The machine model couldn't be identified.

## **MAINTENANCE** Schedule

If there is a need for maintenance of components, please visit the SportsArt website.

cleaning requirements

1.directive 93/42/CEE

2.directive biocide 98/8/CEE

The disinfectant has to be in compliance with Medical Device Directive 93/42/EEC (MDD) and Biocidal Products Directive 98/8/EC (BPD).

It is suited for sensitive synthetic surfaces such as synthetic leather, polycarbonate (PC), acrylic glass and polysulfone, and for the keyboards and control panels.

	Area	Day	Week	Month	Quarter	Year	Notes
1	Exterior	•					Clean.
2	Screws	•					Inspect the looseness and fix
3	Seat	•					Clean with slightly damp wiper
4	Pedals	•					Inspect the looseness and fix.

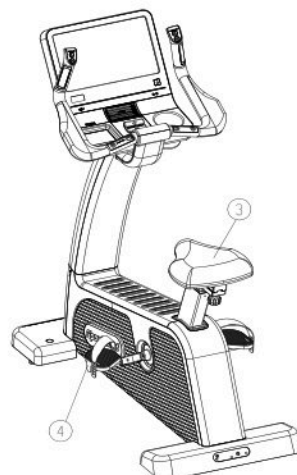

# 11. ACCESSORIES

## ACCESSORIES Standard

### USB CHARGER

The USB charger will provide 5V and 1.5A voltage for charging of smart phone or other devices. However it is compatible only with some tablets, such as iPad. Check your tablet for compatibility before charging.

### CSAFE PORT

Compatible with CSAFE (Communications Specification for Fitness Equipment) Protocol.

## ACCESSORIES Option

### SA WELL+ Member System

This is designed specially by SportsArt to assist the user in managing their workout history. There are three ways to get connected with the member site:

1. Using a smartphone, connect to the unit via Bluetooth/WIFI and use the SA WELL+ App. The App is available for download in the App Store and Google Play.
2. Manage user information and workout data

Visit “[www.gosportsart.com](http://www.gosportsart.com)” for more information about this feature.



No.	Name of button	Function
a	USB port	This port is used for optional data transferring.
b	Bluetooth/WIFI button	When a smart phone is connected wirelessly to the treadmill, press this button to disconnect. Scan the QR code or tap the NFC tag on the console to connect to the equipment again.

## **ACCESSORIES MYE Wireless TV Audio\_Channel Receivers**

[To purchase, please contact MYE Inc. <http://www.myclubtv.com/>]

Multiple TV and audio channels receiving and volume adjustment enabled.

- The following two modules are available for this receiver (to be purchased by client):
  1. MC3R-9(900MHZ), which has to be used with a MYE Wireless TV Digital Audio Channel Transmitter MWTD-S9.
  2. MC3R-8(863MHZ), which has to be used with a MYE Wireless TV Digital Audio Channel transmitter MWTD-S8.Choose a suitable module according to country of location. (Please contact MYE Inc. for detail specification and technical information)  
For example: Wireless TV transmission frequency in America is 900MHZ. Wireless TV transmission frequency in Europe is mostly 863MHZ (or nominally 800MHZ).
- Operation instruction: Turn off treadmill power, plug the receiver into the CSAFE port located at left of display and then turn on the power.
- The VOLUME +/- keys and CHANNEL ▲/▼ keys will be activated once the receiver is plug into the unit.  
Press VOLUME +/- keys to adjust volume settings. The volume setting range is from 0 to 15, with a default setting of 5.  
Press CHANNEL ▲/▼ keys to change channel settings. The channel setting range is from 1 to 32, with a default setting of 1. The display will show "CH XX" during setting.
- Note: Do not unplug the receiver from unit before turning off the power to avoid receiver being damaged.
- The following is a schematic diagram of the connection:

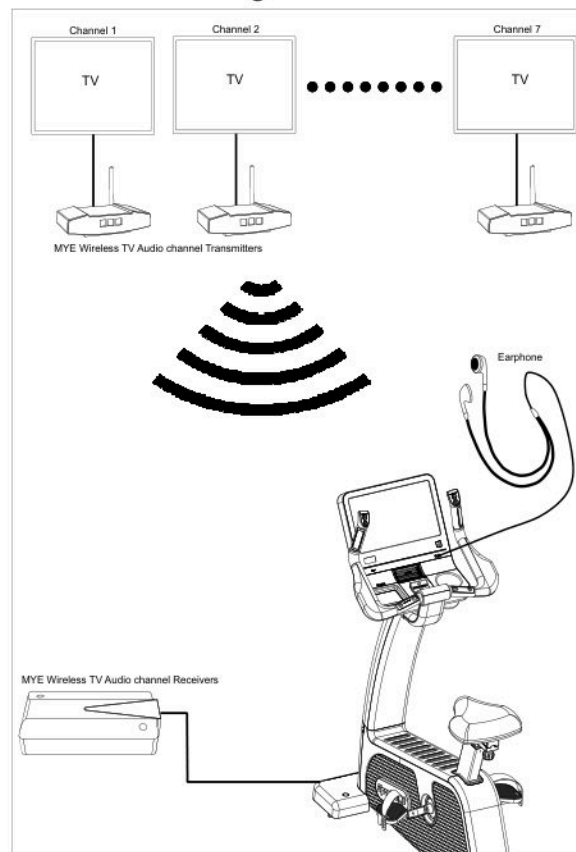

## 12. APPENDIXES

### APPENDIX Operate the ANYcast



With your mobile phone and display ready to project, you can start to use ANYcast to project your phone screen to an external display, and get ready for the big screen entertainment.

#### Choose ANYcast

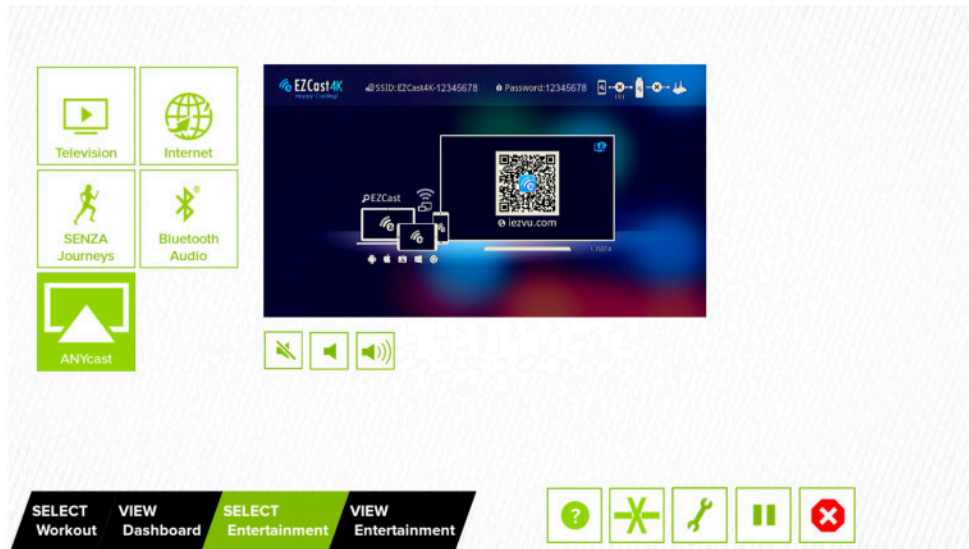
After EZCast4k installation is finished, find “Select Entertainment” at the bottom of the screen and tap the “ANYcast” button to get into ANYcast mode.



Functional Description of ANYcast Control Buttons:

ANYcast Control Buttons	Description
	Help: Tap to display additional information
	Forced Disconnection: Tap to disconnect the currently active user, force the user to log out, and restart active sessions.

## APPENDIX Operate the ANYcast (Continued)

### Instructions For Android Device

1. Enter "View Entertainment" and find SSID number at the top of the screen. (As shown highlighted in red within the figure below).

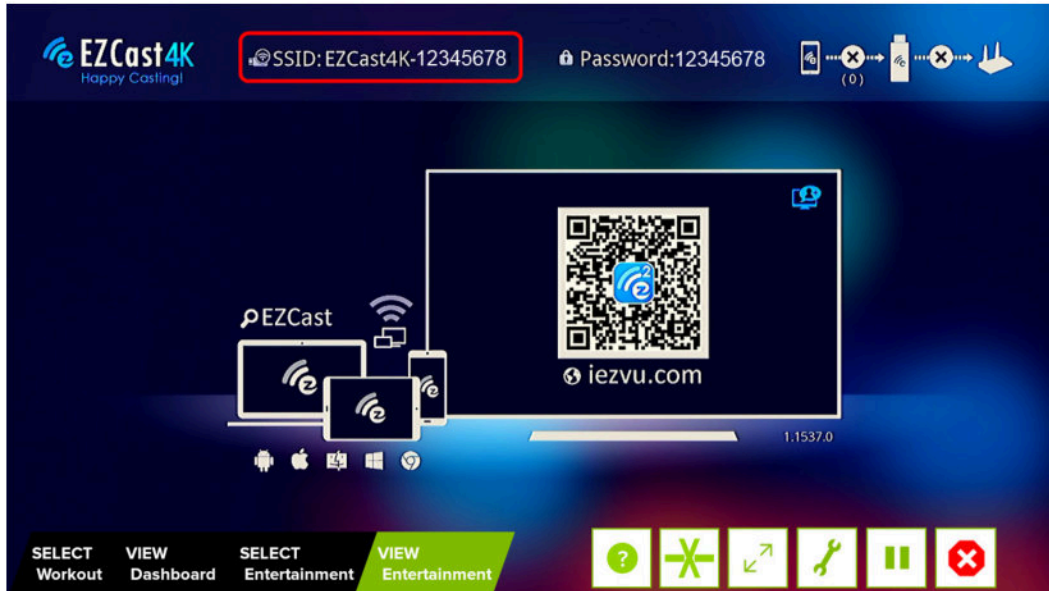

2. Turn on ANYcast on your phone, each brand has their own naming, for example, it's called "Screen Mirroring" for Samsung and Sony.
3. Find "EZCast4K-12345678" (last 8 digits are hardware number, each EZCast4K has different name).
4. Tap to connect.

Note: Open up "Miracast" settings and try to connect to the internet . If there are any problems, confirm specifications with manufacturer before using Miracast. The following table shows some examples for setting Miracast function on different mobile phones:

Mobile Phone Brand	Miracast Setup
HTC	setup --> media output
ASUS	setup --> more --> Play To
Samsung	quick connect --> mirroring
SONY	setup --> connect to Xperia --> concurrent mode
Mi	setup --> more wireless networks --> wireless display
LG	setup --> sharing --> Miracast
Google	setup --> display --> Miracast
InFocus	setup --> projection --> wifi screen share
OPPO	setup --> more wifi --> wifi display
Huawei	Shortcut --> multidisplay
acer	setup --> display --> wifi screen share

## APPENDIX Operate the ANYcast (Continued)

### Instructions For iOS system

1. Enter "View Entertainment" and find SSID number at the top of the screen. (As shown highlighted in red within the figure below).

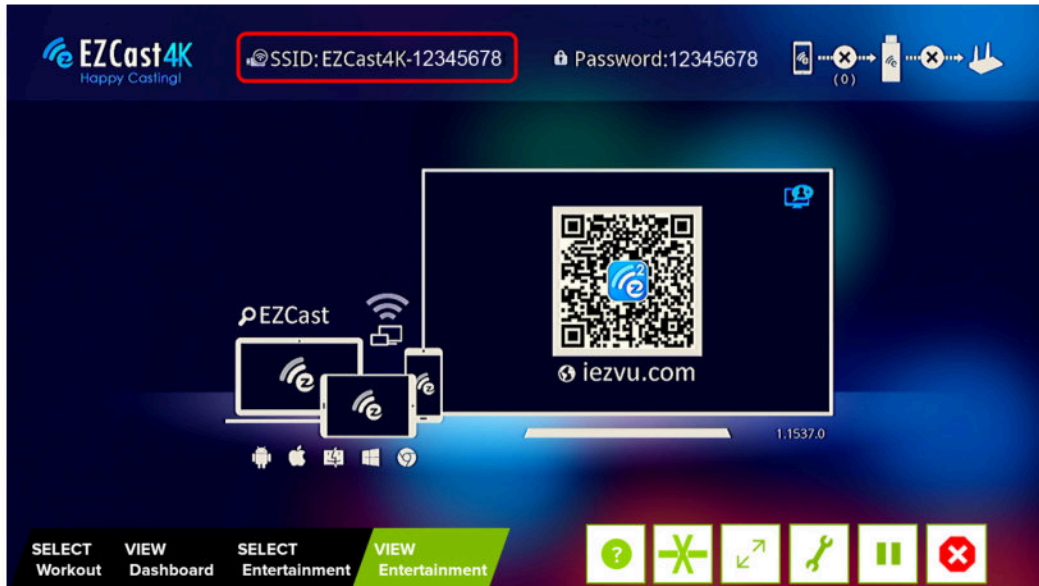

2. Turn on Wi-Fi on your iPhone and search for EZCast4K-12345678 (last 8 digits are hardware number, each EZCast4K has different name), and tap on it.
3. Enter 8 digits password, then tap Join.
4. On your iOS device, swipe up from the bottom of your screen to open Control Center and tap "Airplay".
5. Select EZCast4K-12345678 device.
6. Enable Airplay Mirroring and connect. ( For iOS 9 and above )

### Precautions

1. If the last user is still connected, you can press  to force user to disconnect.
2. Touch the screen and HELP content will disappear to let cast content to display.
3. IOS device cannot connect to WIFI when using Airplay function, try connecting to 3G/4G if needed.

**APPENDIX Specifications**

---

<b>Model</b>	<b>C576U 16"</b>
<b>Dimensions</b>	L : 1260 mm (49.6") W : 685 mm (26.9") H : 1491 mm (58.7")
<b>Overall Weight</b>	101 kg (222 lbs)
<b>Maximum User Weight</b>	150 kg (330 lbs)
<b>Power Requirement</b>	100 – 120 V / 60 Hz (USA) 220 – 240 V / 50 Hz (EUROPE)
<b>Circuit Breaker Current Rating</b>	110 V : 2A 220 V : 2A

# APPENDIX Electronics Block Diagram

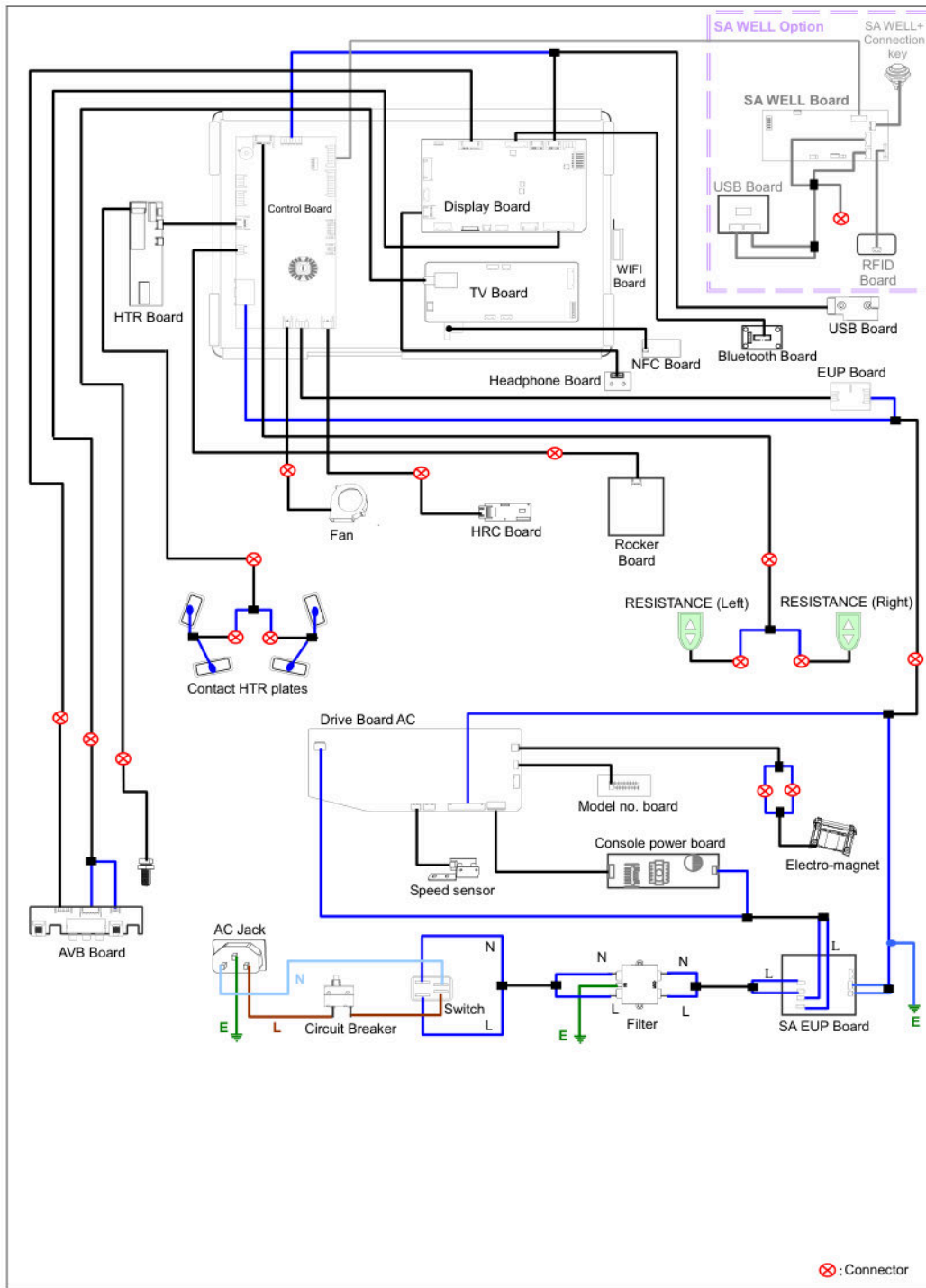

# APPENDIX Exploded Diagrams

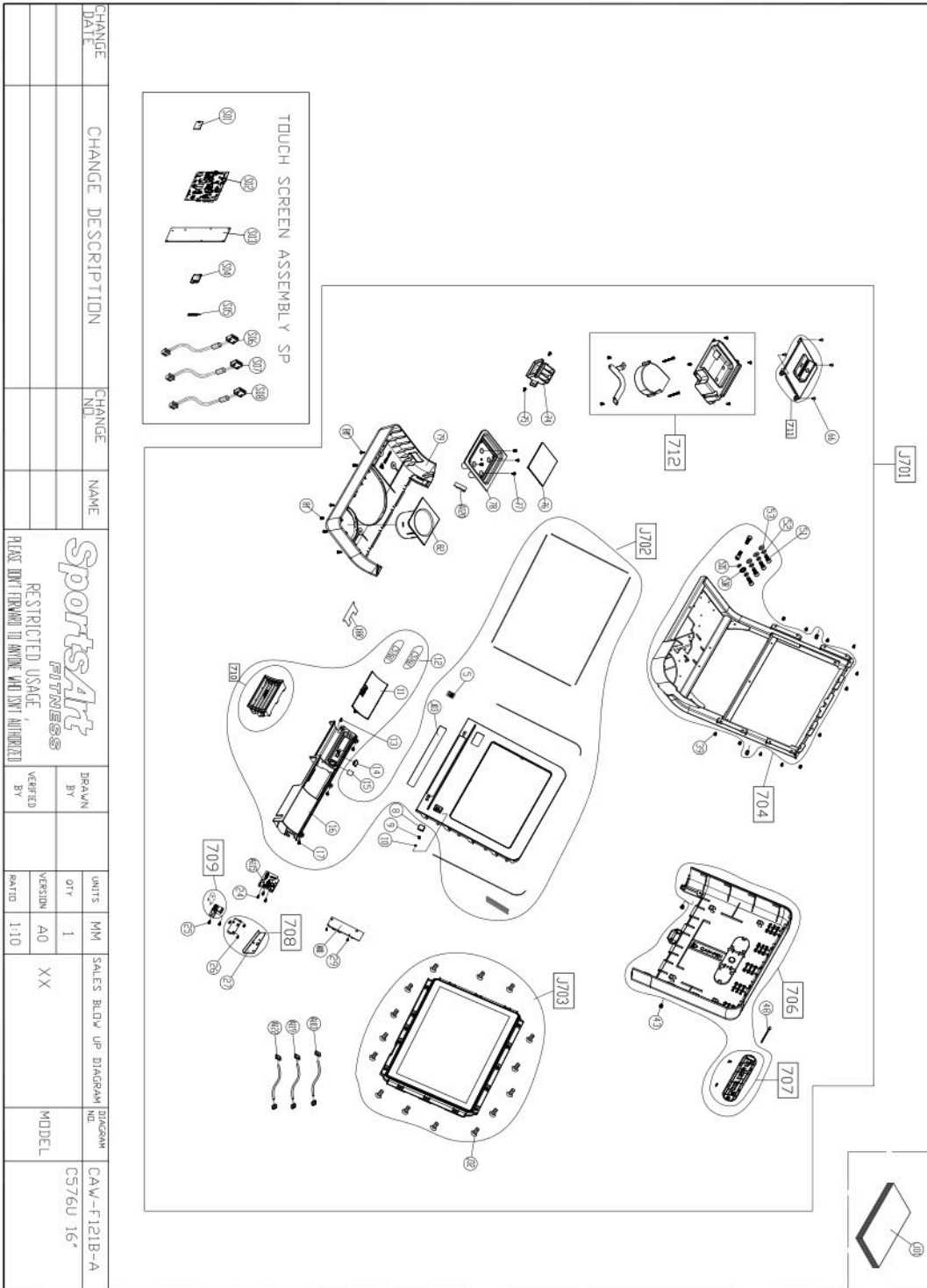

CHANGE DATE	CHANGE DESCRIPTION	CHANGE NO.	NAME

UNITS	MM	SALES BLD'W UP DIAGRAM	DIAGRAM NO.
QTY	1	XX	CAW-F121B-A
VERSION	A0		C576U 16"
RATIO	1:10		

DRAWN BY	VERIFIED BY	MODEL



## APPENDIX Disassembly

(a) RESISTANCE Select Area

(b) Main Frame

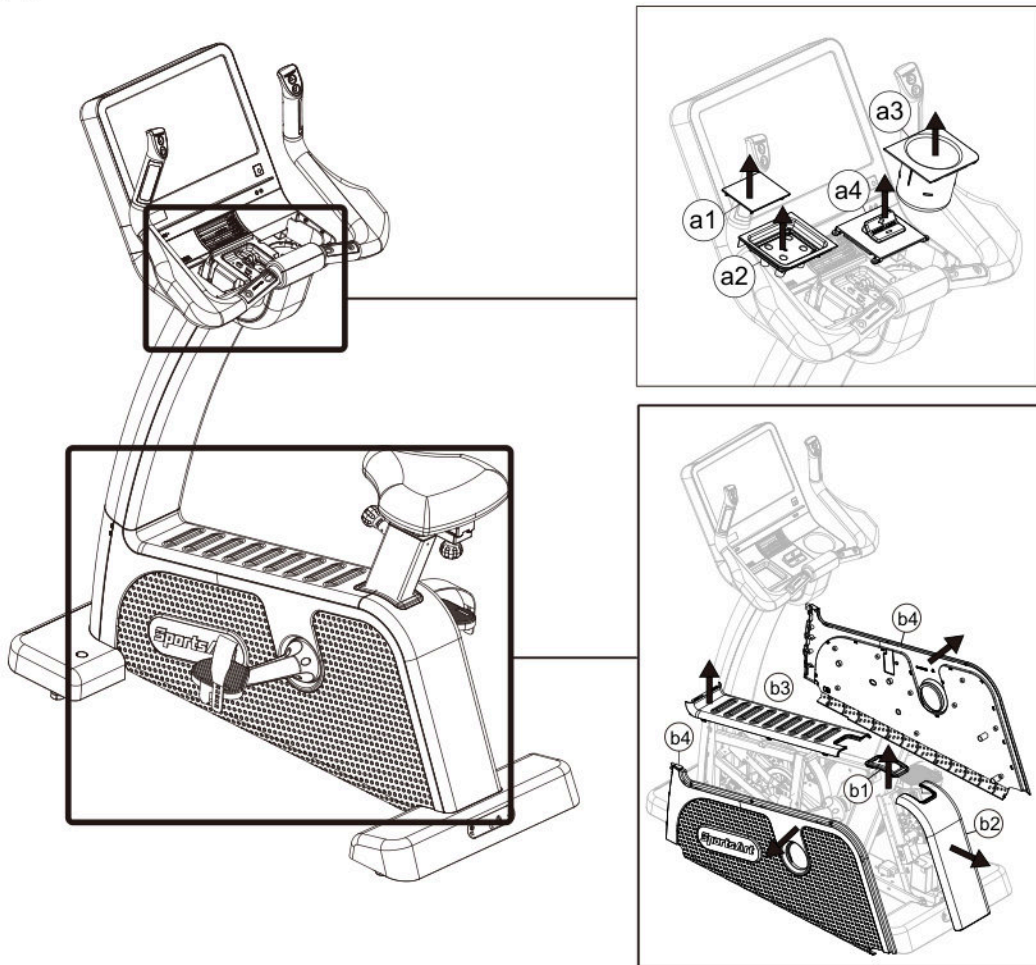

## APPENDIX Disassembly (Continued)

(c) Console

(d) Console Mast

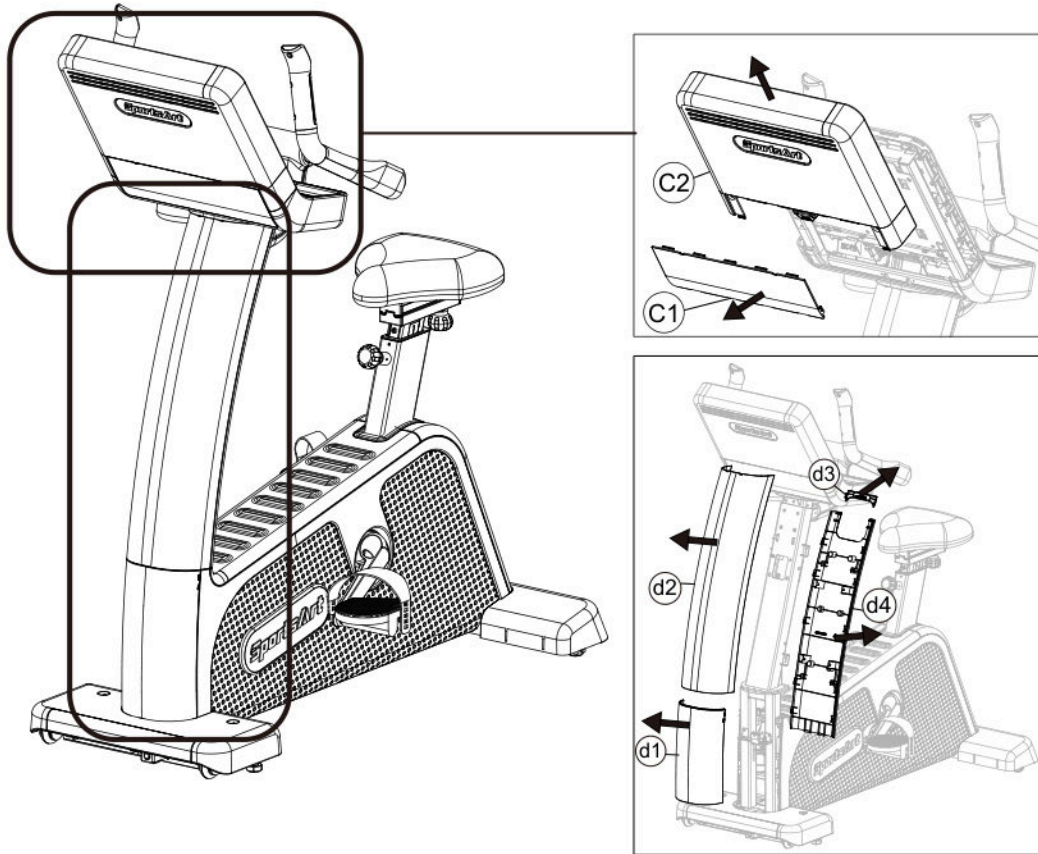

**Your Authorized Distributor**