

# C576U OWNER'S MANUAL CONTENTS

1. INTRODUCTION .....	3
2. SAFETY PRECAUTIONS .....	4
3. WARNING LABEL POSITION .....	6
4. LIST OF PARTS .....	7
5. ASSEMBLE THE PRODUCT .....	9
STEP 1 Install the rear support cover .....	9
STEP 2 Install the seat post .....	10
STEP 3 Install The Console and Console Mast .....	11
STEP 4 Install the Handlebar .....	12
STEP 5 Seat and Pedal .....	13
STEP 6 Install the Plastic Cover .....	14
STEP 7 Move the Bike .....	15
STEP 8 Level the Bike .....	16
STEP 9 Ground Wire .....	17
STEP 10 Seat Fore and Aft Adjustment .....	18
STEP 11 Seat Height Adjustment .....	19
STEP 12 Essential Functions Guide .....	20
STEP 13 Battery Switch .....	21
6. UNDERSTAND THE C576U DISPLAY .....	22
DISPLAY Overview .....	22
DISPLAY Console Panel .....	22
DISPLAY Windows Display .....	24
DISPLAY Specifications .....	24
7. OPERATE THE PRODUCT .....	25
OPERATION Safe Operating Area .....	25
OPERATION Operating position .....	26
OPERATION Step on/off the Bike .....	27
OPERATION Start Screen .....	28
OPERATION Quick Start .....	28
OPERATION User Setting Procedure .....	28
OPERATION Workout Programs .....	30
OPERATION During Exercise .....	35
OPERATION Cool Down .....	35
OPERATION Stop Exercise .....	36
OPERATION Workout Summary .....	36
OPERATION Idle Mode .....	36
OPERATION Energy Smart Function .....	36
OPERATION User Parameter Setting .....	37
8. ABOUT HEART RATE DETECTION .....	39
HEART RATE Telemetry .....	39
HEART RATE Contact .....	39

## **C576U OWNER'S MANUAL CONTENTS**

9. GUIDELINES FOR EXERCISE .....	40
10. MAINTENANCE .....	41
MAINTENANCE Safety Precautions .....	41
MAINTENANCE Error Messages .....	42
MAINTENANCE Schedule .....	43
11. ACCESSORIES .....	43
ACCESSORIES Standard .....	44
ACCESSORIES Option .....	45
ACCESSORIES MYE Wireless TV Audio_Channel Receivers .....	47
12. APPENDIXES .....	48
APPENDIXES Specifications .....	48
APPENDIXES Electronics Block Diagram .....	49
APPENDIXES Exploded Diagrams.....	50
APPENDIXES Disassembly .....	52

# 1. INTRODUCTION

Congratulations on the purchase of a high quality SportsArt product, the C576U upright exercise cycle. Constructed of high quality materials and designed for years of reliable performance, this product was made for full commercial use.

Before this product is assembled or operated, we recommend that you familiarize yourself with this manual. Understanding the correct assembly and operation of this product will help ensure that exercisers obtain their fitness goals safely and successfully.

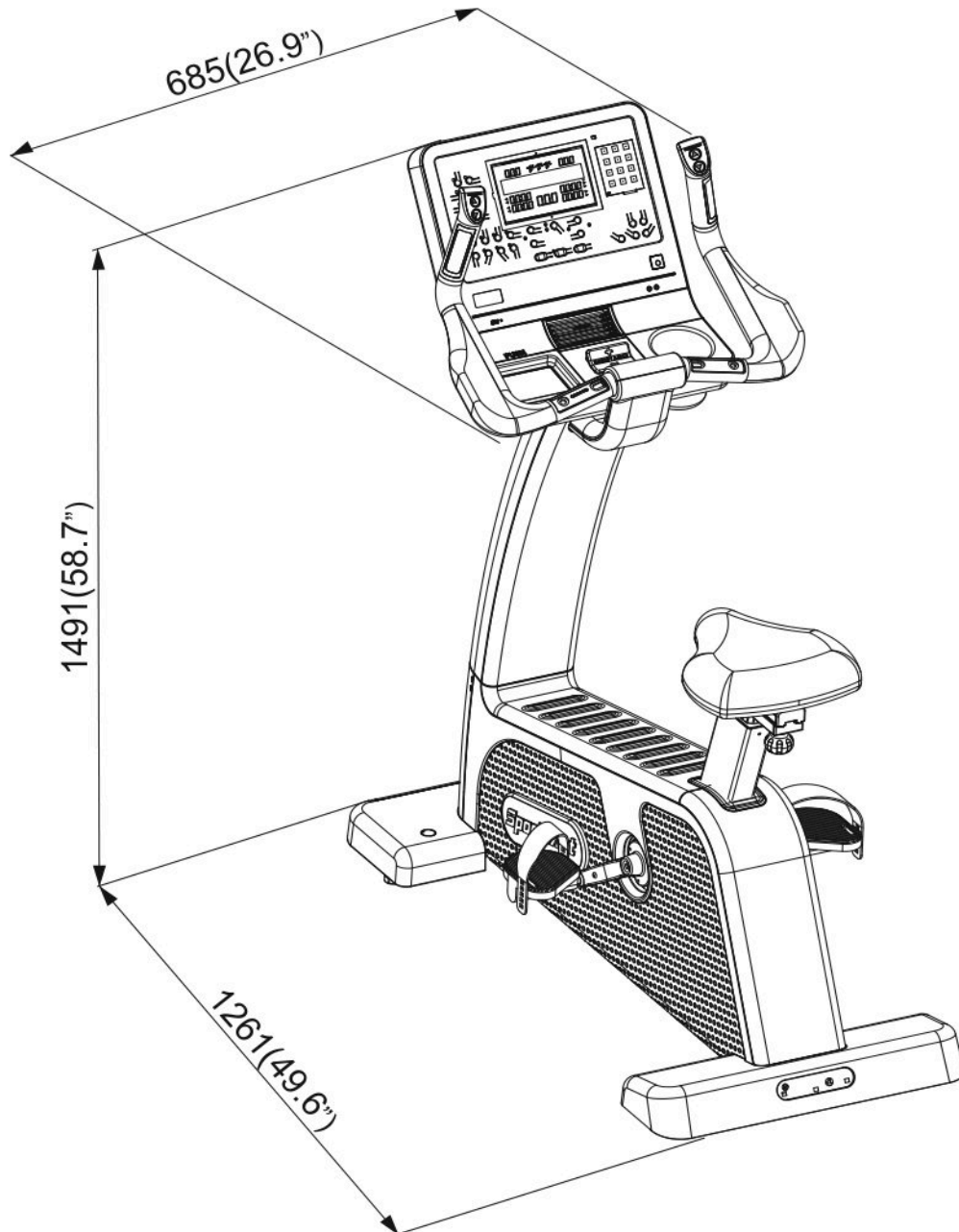

## 2. SAFETY PRECAUTIONS

Your SportsArt bike was designed and built for optimum safety. However certain precautions apply whenever you use your bike.

Please read the entire manual before assembly and operation. Also, please note the following safety precautions:

- Read instruction manual before using.
- Please read the instructions carefully and install the bike as instructed.
- Assemble and operate the bike on a solid, level surface. DO NOT use outdoors or near water.
- Do not let children 12 or younger on or near the product.
- Check the bike before every use. Make sure all parts are assembled, and all fasteners are tightened. DO NOT use the bike if the unit is disassembled in any way.
- Keep your hands away from moving parts.
- Wear proper workout clothing; DO NOT wear loose clothing. DO NOT wear shoes with leather soles or high heels. Tie all long hair back. DO NOT go barefoot on this product.
- Be careful when mounting and dismounting the unit.
- The bike may or may not stop immediately if an object becomes caught or impedes normal motion.
- Do not use accessories or parts that are not specifically recommended by the manufacturer (SportsArt). Such parts might cause injuries or cause the unit to fail and void the warranty. We will not be responsible for any safety issue that arises due to the misuse of accessories or parts. At the same time, we will terminate the warranty terms of this equipment.
- Close supervision is necessary when this bike is used by, on, or near children 12 or younger, invalids, or disabled persons.
- Use this bike only for its intended use as described in this manual.
- Never operate this bike if it has been damaged in any way. If it is not working properly, or has been dropped or damaged, contact your dealer.
- Keep all air ventilation areas free of blockage.
- Never drop or insert any object into any opening.
- DO NOT operate where aerosol (spray) products are being used or where oxygen is being administered.
- The general user weight limit for this bike is 150kg (330lb).
- This bike is not intended for use by persons (including children 12 or younger ) with reduced physical, sensory or mental capabilities, or lack of experience and knowledge, unless they have been given supervision or instruction concerning use of this bike by a person responsible for their safety.

## 2. SAFETY PRECAUTIONS (CONTINUED)

- Children 12 or younger should be supervised to ensure that they do not play on or near the product.
- Maintenance and repair must be performed by trained service personnel only. Improper maintenance would not only damage the machine, but also may present a danger to the exerciser.
- Warning that any of the adjustment devices that could interfere with the user's movement should not be left projecting.
- It is not suitable for therapeutic purposes.
- **WARNING** — This stationary training equipment is not suitable for high accuracy purposes.

### **Caution**

If you feel any pain or abnormal sensation, **STOP YOUR WORKOUT** and consult your physician immediately. Work within your recommended exercise level. **DO NOT** work to exhaustion.

Before beginning any exercise program, you should consult with your doctor. It is recommended that you undergo a complete physical examination.

Note: This equipment has been tested and found to comply with the limits for a digital device, pursuant to part 15 of the FCC Rules. These limits are designed to provide reasonable protection against harmful interference in a residential installation. This equipment generates, uses, and can radiate radio frequency energy and, if not installed and used in accordance with the instructions, may cause harmful interference to radio communications. However, there is no guarantee that interference will not occur in a particular installation. If the user desires to correct such interference, it is at the user's own expense.

### **Warning**

Heart rate monitoring systems may be inaccurate. Over exercise may result in serious injury or death. If you feel faint, stop exercise immediately.

### 3. WARNING LABEL POSITION

If you are in a Non-English speaking country, you can attach the warning label to the console panel as shown, otherwise, you can also stick it on a place where is clear and obvious. (please use the French version label in French-Speaking areas in North America, and the label will not be included in the other regions.)

Note: Depending on the model, the appearance of the console is different, but the labeling position is the same.

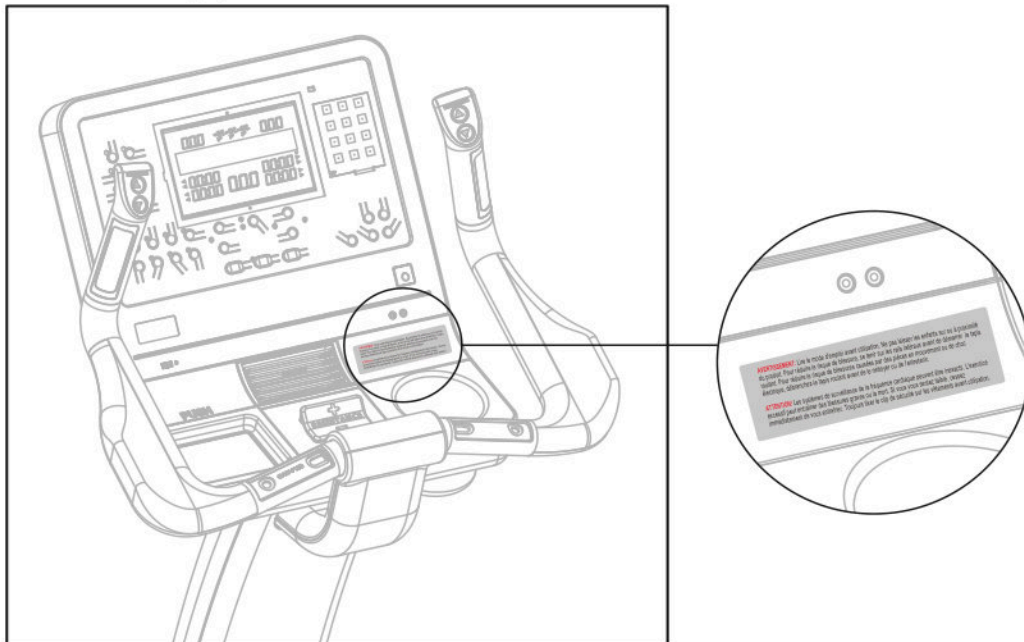

## 4. LIST OF PARTS

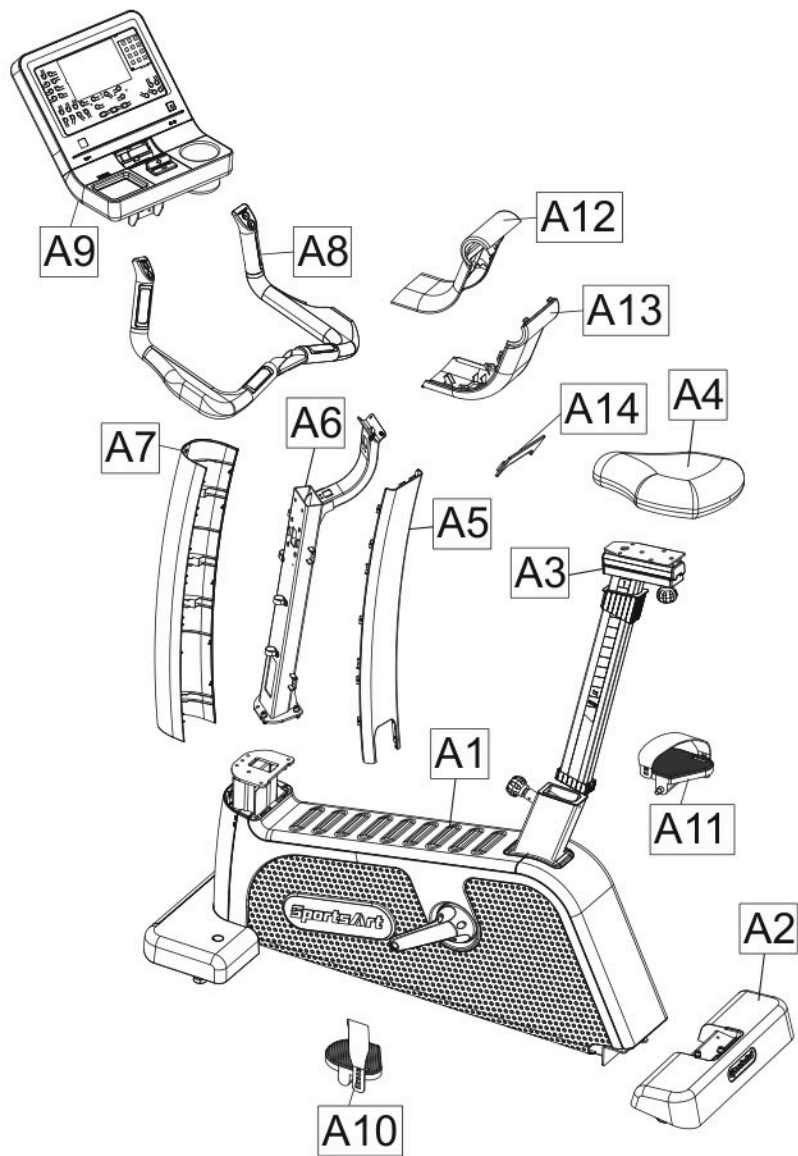

Assembly Parts					
No.	Name	Qty.	No.	Name	Qty.
A1	Main frame	1	A8	Handlebar	1
A2	Rear Support Cover	1	A9	Console	1
A3	Seat Post	1	A10	Left pedal	1
A4	Seat	1	A11	Right pedal	1
A5	Inner Pedestal Cover	1	A12	Handlebar Cover(Inside)	1
A6	Console Mast	1	A13	Handlebar Cover(Outside)	1
A7	Outer Pedestal Cover	1	A14	Console Mast Cover	1

## 4. LIST OF PARTS (CONTINUED)

TOOLS KIT				
No.	Name	Qty.	Specification	Notes
	T-shaped Allen Wrench	1	M6*L108	
	L-shaped Allen Wrench	1	M5*L65mm*W25	
	Two-Way Screwdriver Bit with Black Handle	1	Flat and Phillips	
	Double Open-End Wrench	1	8mm*10mm	
	Double Open-End Wrench	1	12mm*15mm	
	Double Open-End Wrench	1	13mm*15mm	

Pre-Installed Hardware			
No.	Name	Specification	Notes
21	Round head inner hex screw	M8*P1.25*L25	
	Flat Washer	D20*d8*t2.0	
	Spring Washer	M8	
22	Round head inner hex screw	M8*P1.25*L25	
	Spring Washer	M8	
	Flat Washer	D20*d8*t2.0	
23	Round head inner hex screw	M8	
24	Nylon Hex Lock Nut	M6*P1.0*H6	
	Round head inner hex screw	M6	
25	Round head inner hex screw	M6*P1.0*L20	
	Spring Washer	M6	
26	Spring Washer	M6	
	Flat Washer	D16*d6.3*t1	
	Hex Cap Screw	M6*P1.0*L15	

## 5. ASSEMBLE THE PRODUCT

### STEP 1 Install the rear support cover

Remove the cover (a) and secure the rear support cover (A2) with the pre-installed screws (21), once completed, install the cover (a) back in place and be sure it is assembled properly to the rubber gasket around the seat post.

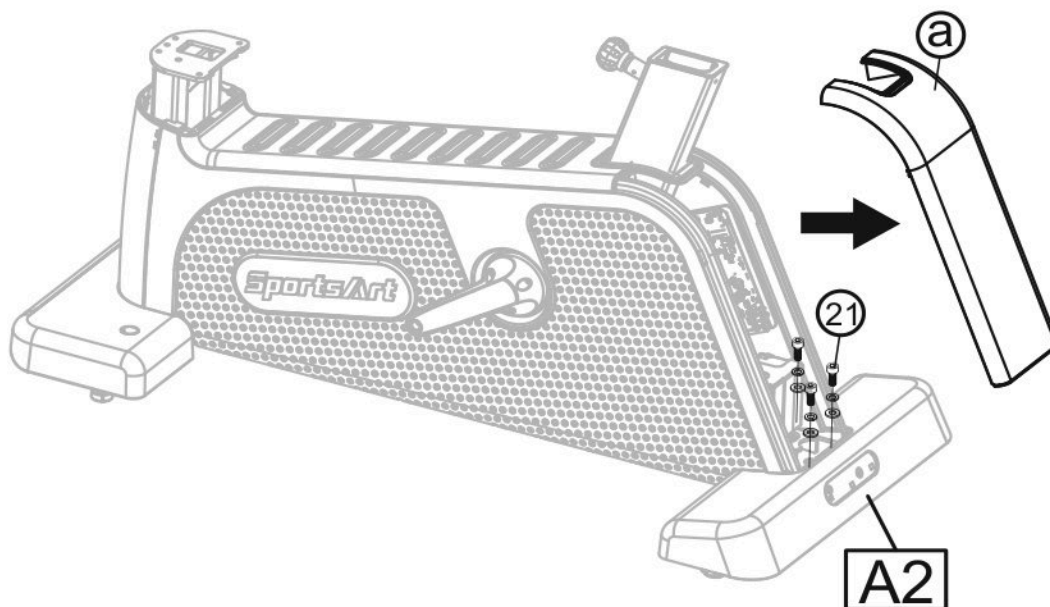

## STEP 2 Install the seat post

Pull the lock knob, and install the seat post into the seat post housing on the main frame. (A3) ( If you cannot install the seat post in place, please check if the lock knob is fully turned as shown.) Release the lock knob and install the plastic piece on the seat post to the post housing with the screws.

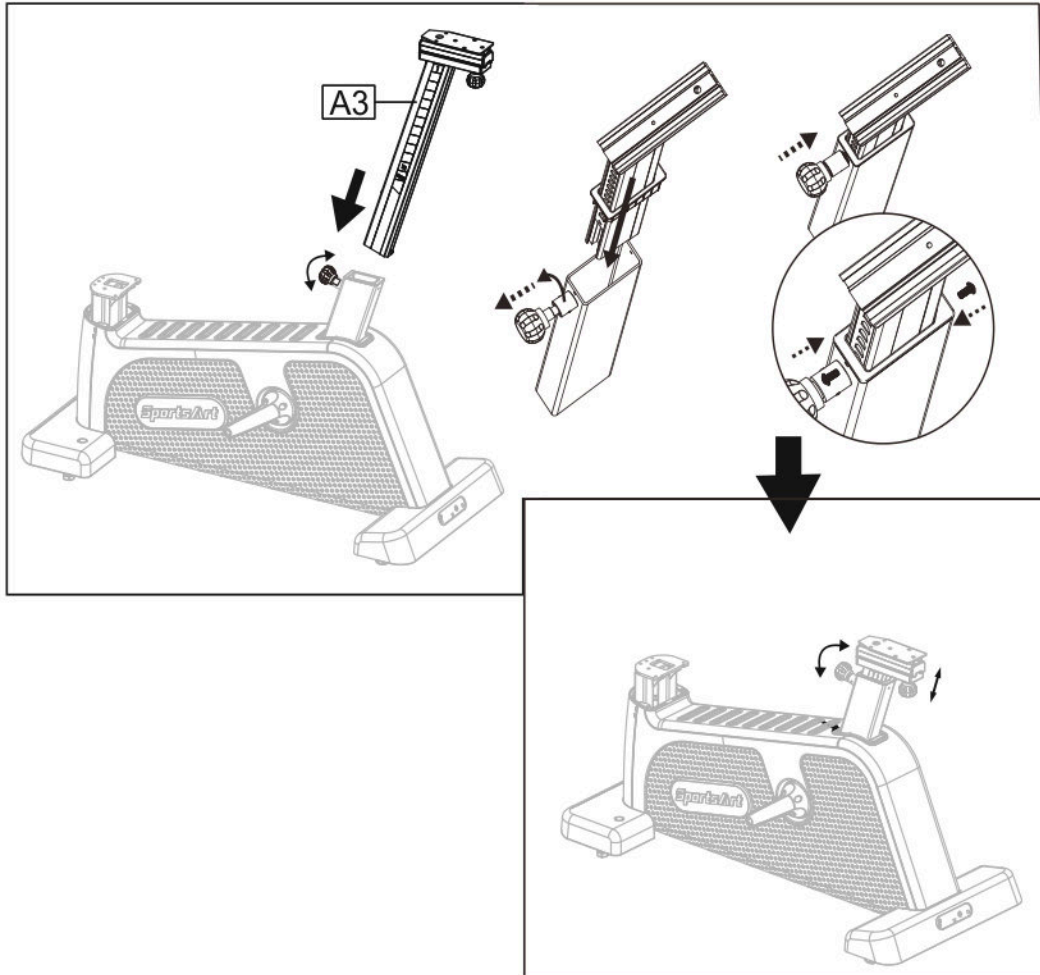

### STEP 3 Install The Console and Console Mast

- (a) Secure the console mast (A6) with the pre-installed screws (22).
- (b) Secure the console (A9) to the console mast (A6) with the pre-installed screws (23). Be careful not to pinch the power cord while assembling.
- (c) Use the feeder cord to pull the cables out from the console mast (A6) and thread them through the opening as shown, then connect to the cables of the console (A9). After connecting, place the cables back inside the console mast (A6). Once completed, please untie the feeder cord.

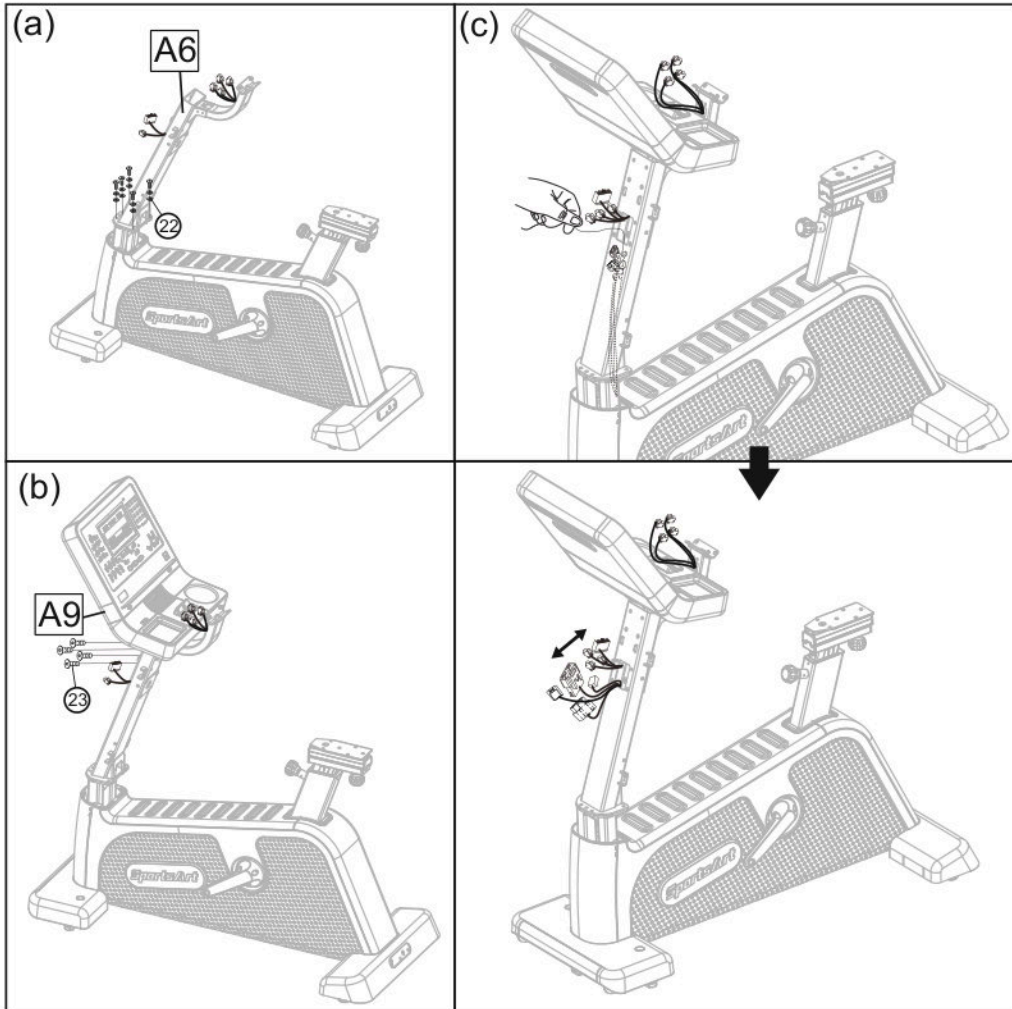

## STEP 4 Install the Handlebar

- (a) Secure the handlebar (A8) to the console mast (A6) with the pre-installed screws. (26)
- (b) Plug in the cables to the connectors on the handlebar (A8). Once completed, the cables should be arranged and placed back inside the opening as shown.

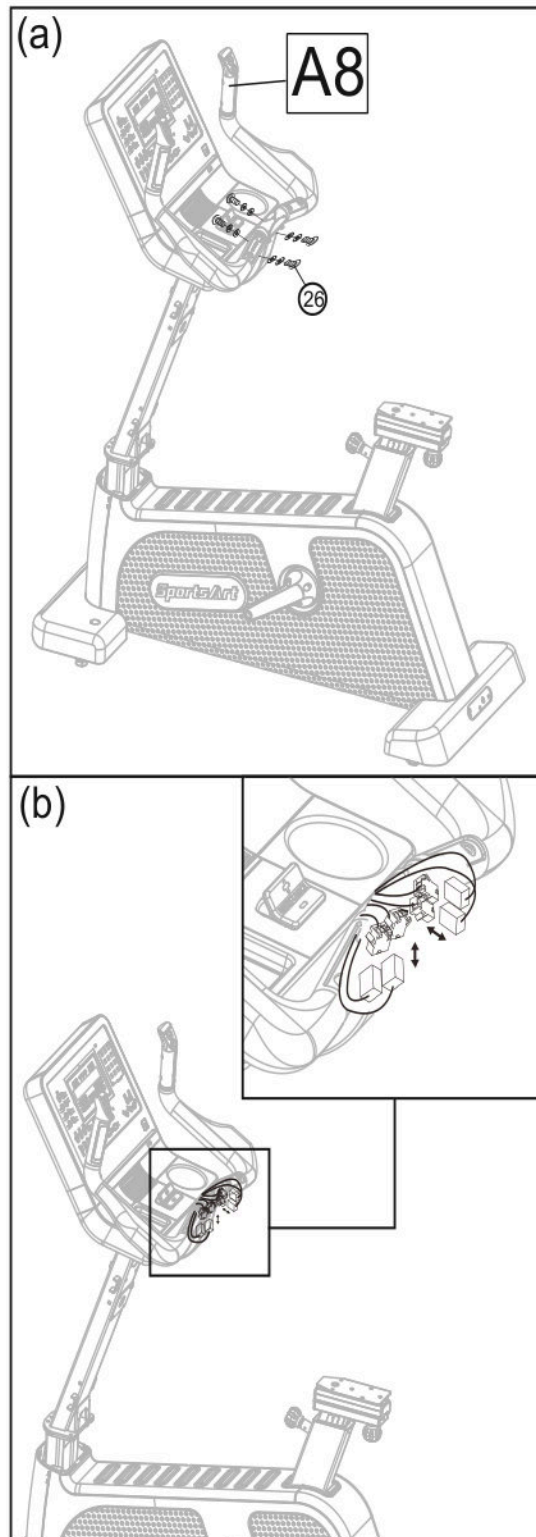

## STEP 5 Seat and Pedal

(a) Place the seat (A4) properly align to the hole on the seat post, then secure the seat with the pre-installed screws and nuts (24).

(b) Use the tool enclosed with the product to secure the left/right pedal(A10/ A11) to the crank on the main frame, please note that pedal spindle threads are different from left side and right side . DO NOT install in reverse. The tool should not be too short, otherwise, it can damage the pedals. (please use the attached wrench size in 13\*15)

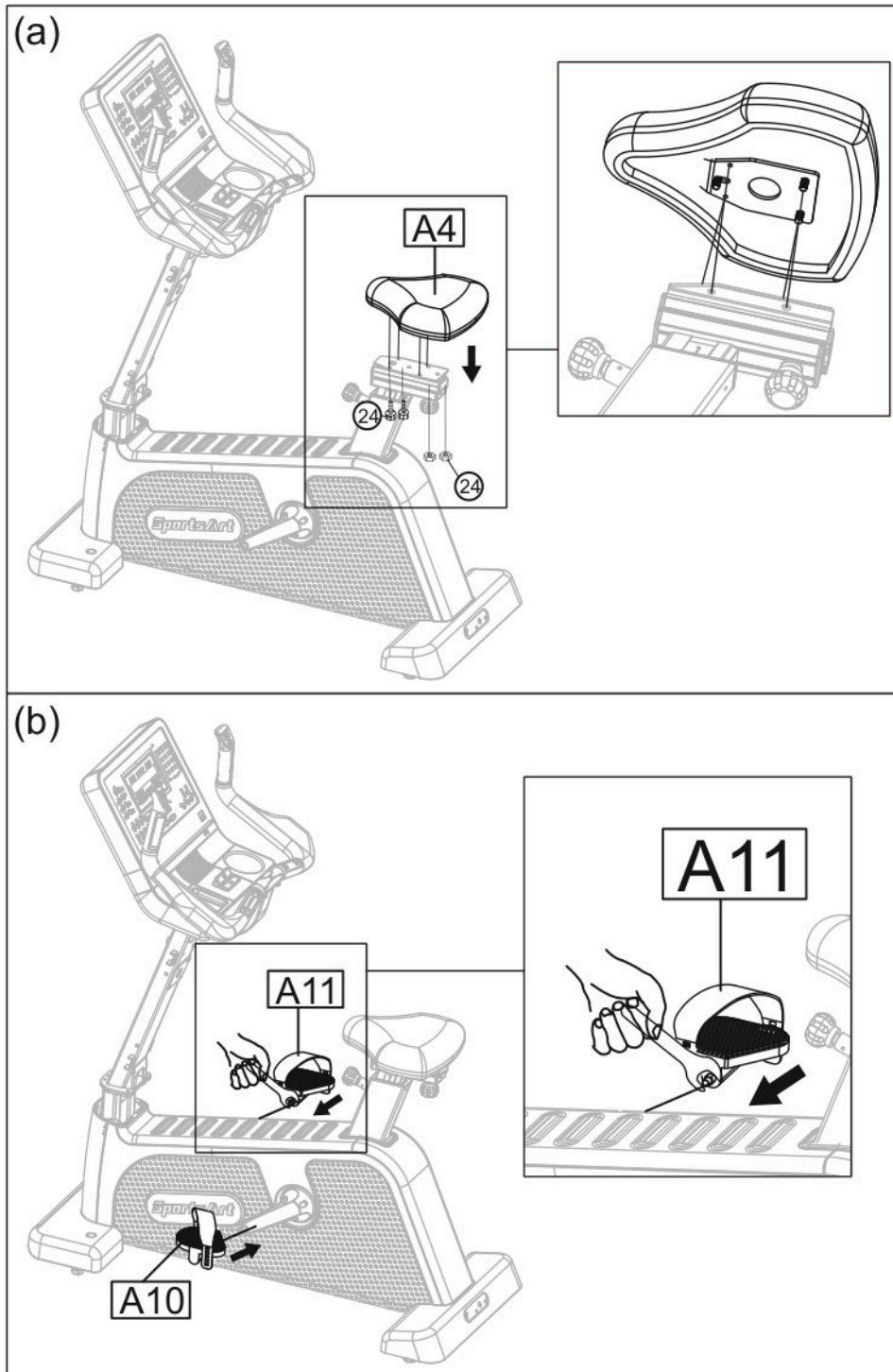

## STEP 6 Install the Plastic Cover

(a) Secure the outside cover of the handlebar (A13) with the pre-installed screws, then install the inside cover of the handlebar (A12) in place afterwards.

(b) Secure the inner pedestal cover (A5) with the pre-installed screws, then install the cover (A14) in place afterwards.

(c) Remove the lower cover first before installing the outer pedestal cover (A7) to the main frame. Please note that, the outer cover has to be pushed up first and then push down to fix it in place, when finished, install the lower cover back in place.

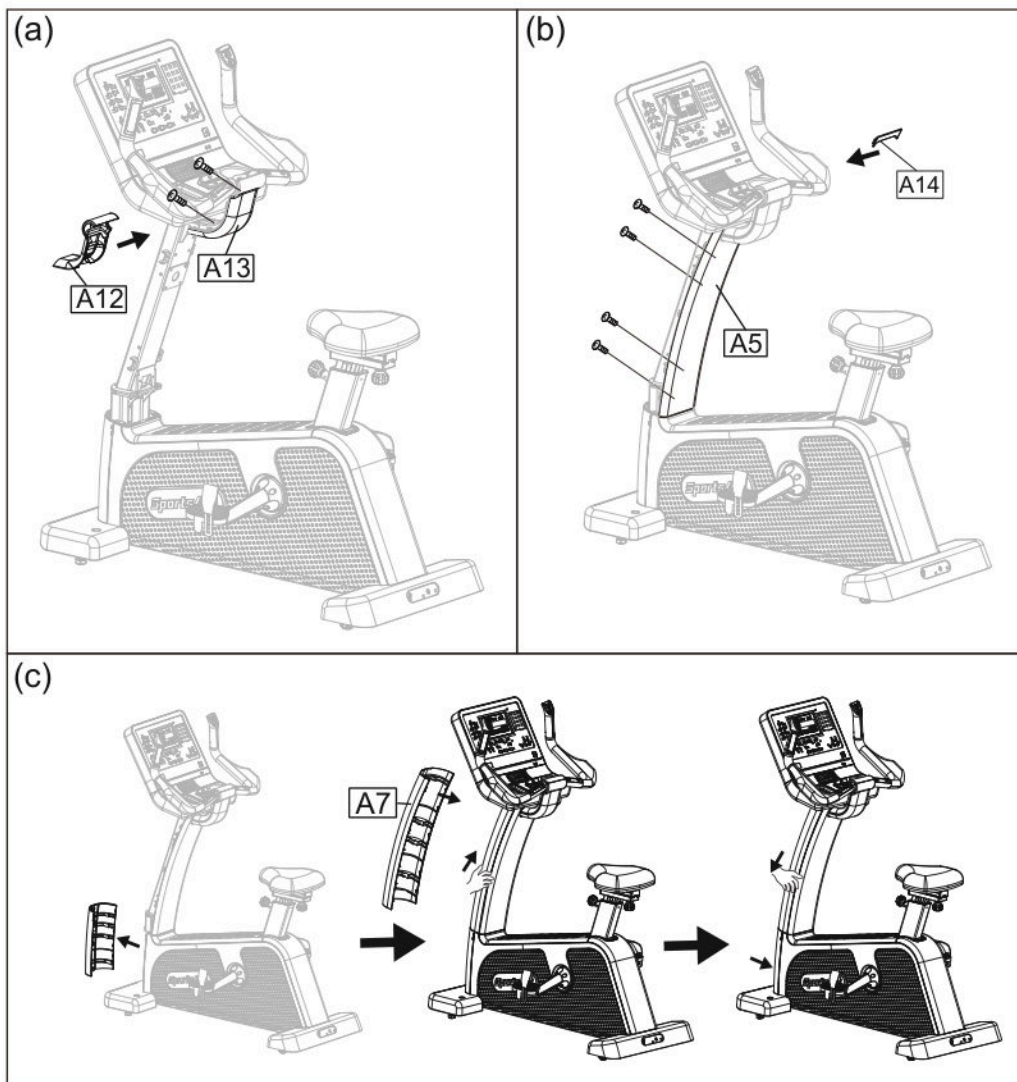

## STEP 7 Move the Bike

Please follow the instructions as below to move the bike into place for use.

(a) Please stand in front of the bike, against the front wheel with one foot, then tilt the bike for moving.

(b) Hold on the handlebar with both hands and roll it into place.

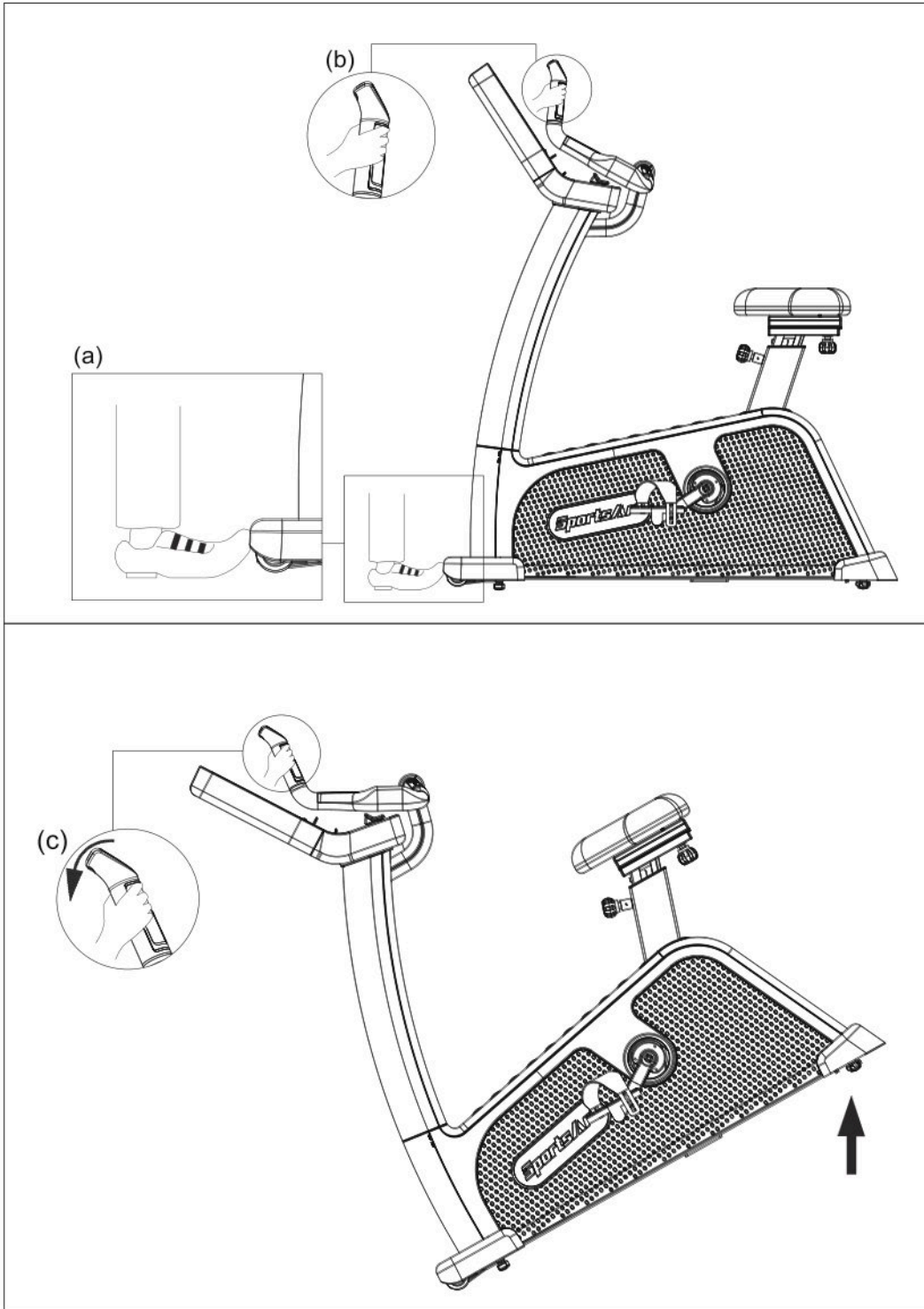

## STEP 8 Level the Bike

Please apply force to the end of the bike to check if the leveling knob is stable on the ground.

If not, adjust the levelers as follows:

- (a) Loosen the leveling knob.
  - (b) Rotate the leveling knob downward to the ground to make it steady.
  - (c) Tighten the leveling knob.
- (d) After the bike is installed and positioned, do the test operation. If necessary, make adjustment to be sure the equipment works properly.

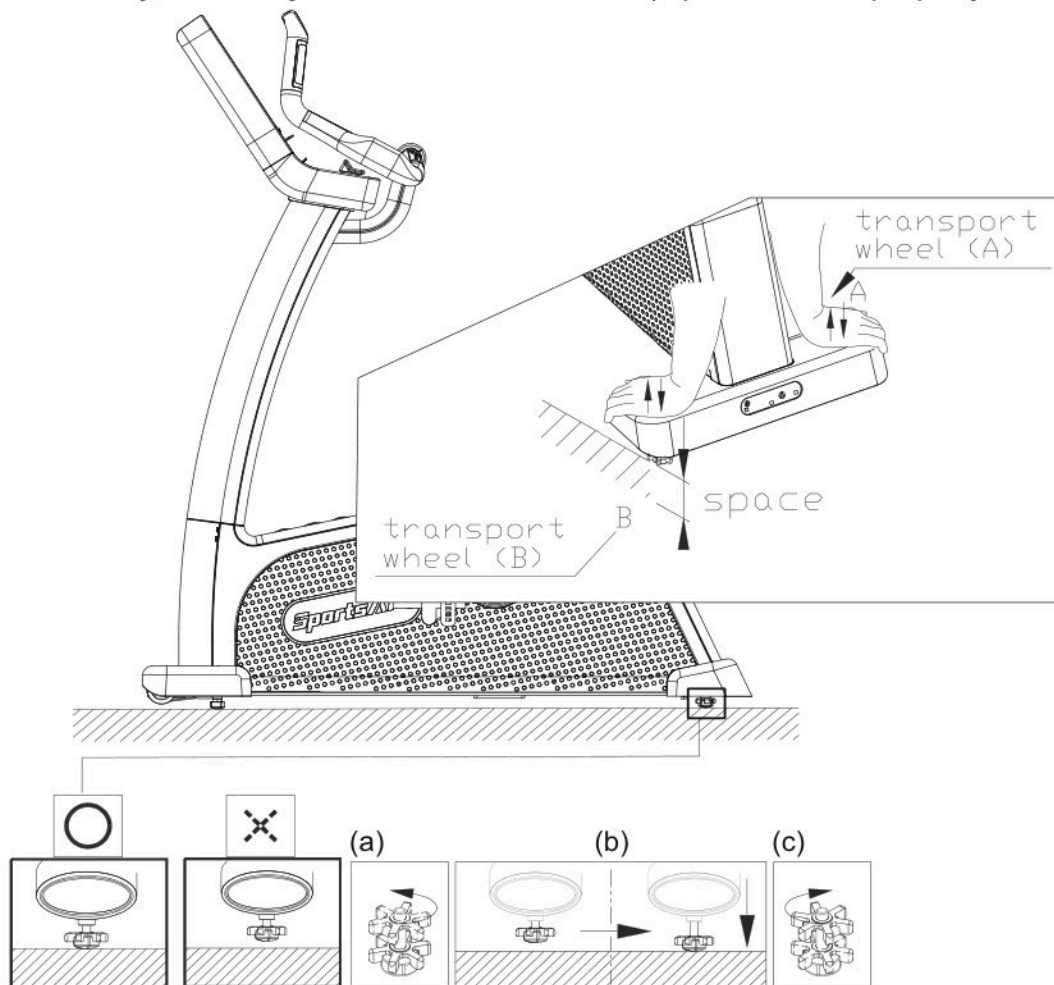

## STEP 9 Ground Wire

In order to avoid electric shock and current leaking, the additional ground wire is provided in the product.

For safety, please connect this wire between the machine and the ground actually.

Assembly Instruction: As shown in the picture, please screw the ground wire to the frame and the other end to the ground of the room.

The picture below is for your reference.

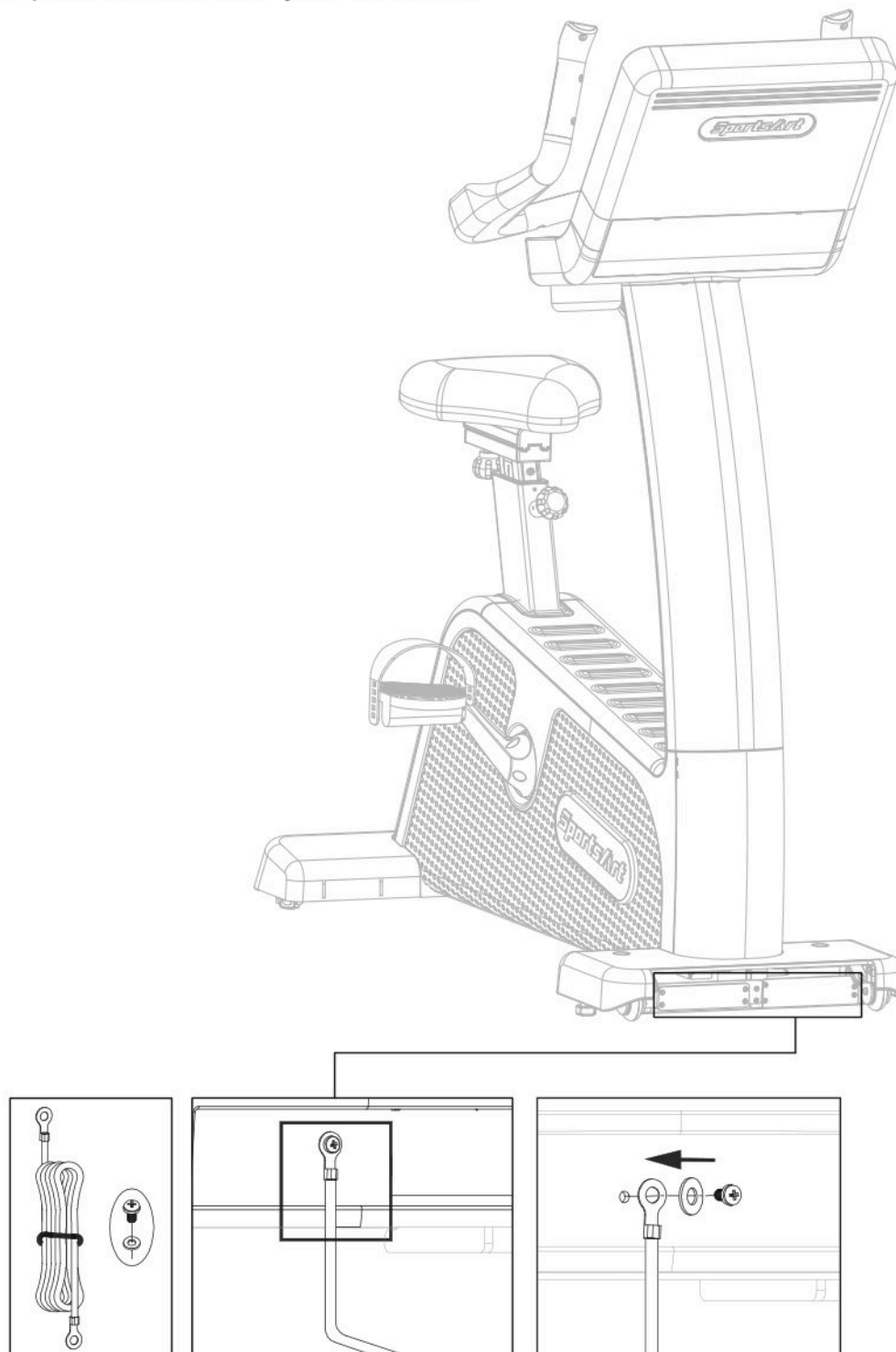

## **STEP 10** Seat Fore and Aft Adjustment

(a) Loosen the lock knob under the seat then you can move the seat easily.

(b) Adjust the seat position by moving it forward and backward until you find the right position.

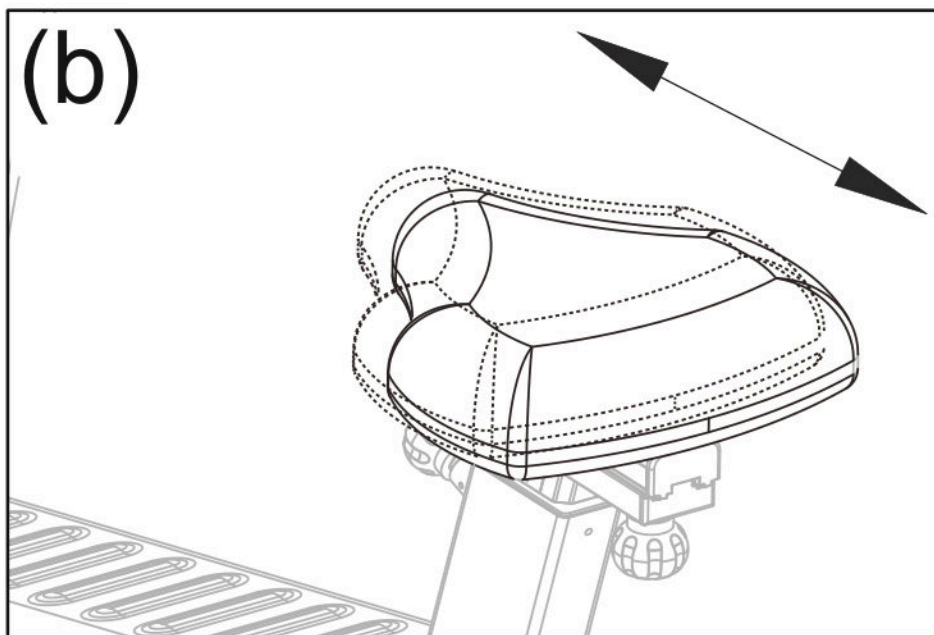
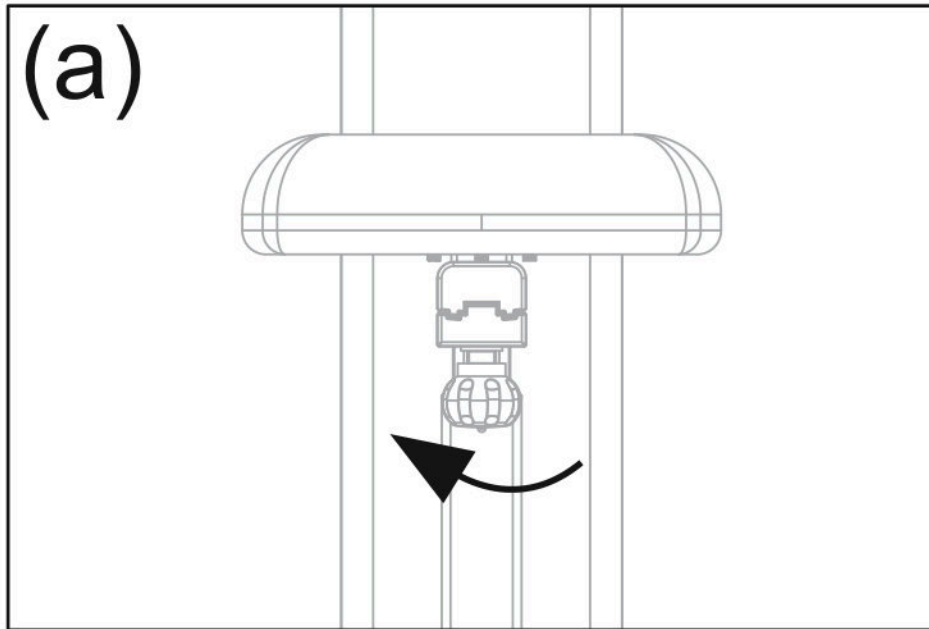

## STEP 11 Seat Height Adjustment

Loosen the lock knob in front of the seat to adjust the height. After adjustment, press the lock knob back into place and fully tighten it. to reduce the sway of the seat during use.

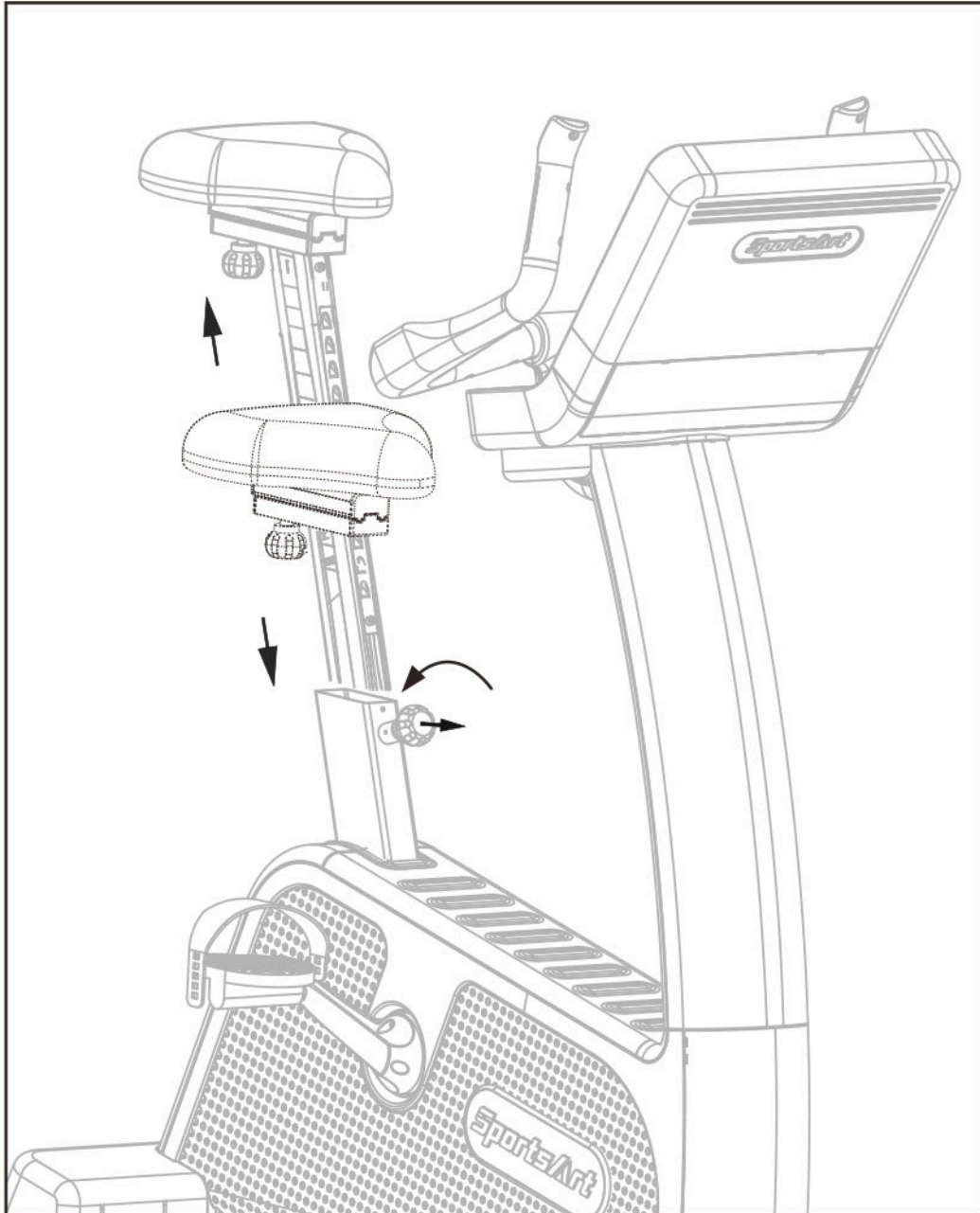

## STEP 12 Essential Functions Guide

**RESISTANCE:** Adjust the weight or force you need to place on the pedals to push them.

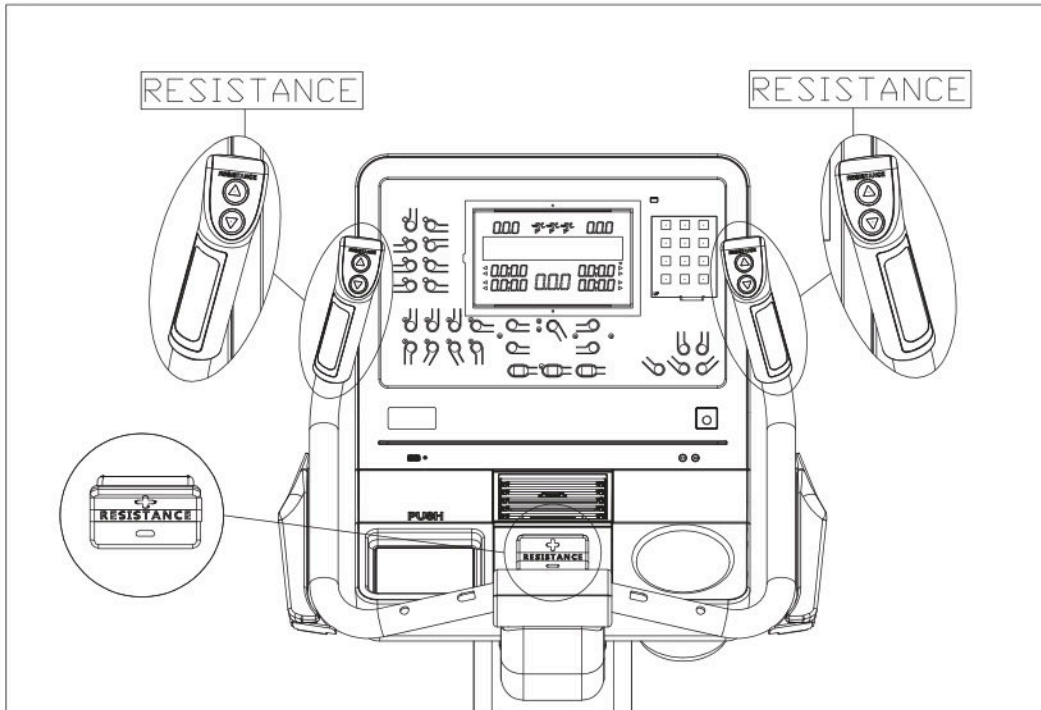

## **STEP 13** Battery Switch

---

Before start using make sure that the battery switch on the unit is turned on.

0-1. The unit can generate its own power. The battery is a backup power source in case of insufficient power which may cause the unit fail to work.

0-2. Give C576U a proper charge for a minimum of 2 hours before using it for the first time after finished assembling the unit.

0-3. The battery lasts 1.5 years after fully charged the first time. Battery life varies by use

0-4. To prevent your battery from draining, turn the unit all the way off when not in use for an extended period of time.

Specification of Battery Charger:

(1) Input voltage: AC100-240V, 50/60Hz

(2) Output voltage: 33 V

(3) Rated Output Current: 1.9A

(4) Output connector: DC:2.1,

(5) Diameters & specifications of the plug:

Outside diameter: 5.5mm / inside diameter: 2.1mm.

Potential: positive inside, negative outsi



## 6. UNDERSTAND C576U LCD DISPLAY

### DISPLAY Overview

In this chapter, you will learn how to use and set up the console of your bike. Please read the entire manual prior to using the bike to get the best exercise efficiency and enjoy your ride.

### DISPLAY Console Panel



No.	Title	Function
1	LCD Window	Display the data of " RESISTANCE,TIME, DISTANCE, HEART RATE, CALORIES ".
2	GOAL Select Area	Options: TIME, DISTANCE,CALORIES.
3	PROGRAMS Se-lect Area	MANUAL, INTERVAL, PLATEAU, RAN- DOM, FAT BURN, FIT TEST, CUSTOM HR, WT LOSS CARDIO.
4	ENTER	After entering data, press <ENTER> to confirm.
5	QUICK START	Skip the program selection and setting to start training instantly.

**DISPLAY Console Panel (Continued)**

No.	Title	Function
6	QR code and NFC tag	(1) Without the SA WELL+: Only link to SPORTSART website when scanning the QR CODE and NFC label.  (2) With the SA WELL+: Use the APP on your mobile scanning the QR CODE and NFC label to connect to the bike to your personal exercise records.
7	USB Port	Used for software updates but can also be used as a charging port.
8	SA WELL+ Device	Data management(This function is only available if you purchase SA WELL+)
9	RESISTANCE+ -	Press <RESISTANCE +/-> to set the resistance.
10	Numeric Keypad	Press these keys to directly input numeric values.
11	CHANGE DISPLAY	Press this key to switch the message on the LCD display window.
12	Fan Speed Switching	Cycles thru 3 different fan speeds.
13	TV WIRELESS AUDIO RECEIVER Control Area	Change volume and TV audio channel (in conjunction with MYE option)
14	Wake Button	Press this key to wake-up the console panel.
15	Headphone Port	Plug in the headphone to hear the sound from the TV WIRELESS AUDIO RECEIVER.
16	STOP	Press this key to stop the bike; Hold this key to return to the start screen.

## DISPLAY Window Display

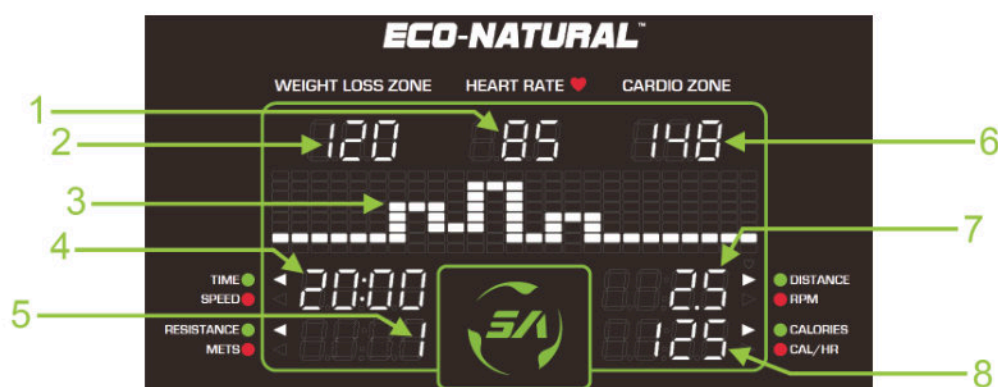

No.	Function
1	Display the data of your heart rate value. (Displayed when BOTH HANDS hold on the sensor.)
2	The WT LOSS 65% heart rate value.
3	Display the messages or the illustration.
4	TIME : Display the total time of the workout or the remaining time to exercise. SPEED : Display your current speed.
5	RESISTANCE : Display your current resistance. METS : Display your METS value.
6	The CARDIO 80% heart rate value.
7	DISTANCE : Display the total distance of the workout or the remaining distance to exercise. RPM : Display the pedal revolutions per minute.
8	CALORIES : Display the calories you have burned during the exercise. CAL/HR : Display the calories that you have burned per hour.

## DISPLAY Specifications

Parameter	Spec.
RESISTANCE	1-40
CAL/HR	0-9999 K-CAL
TIME	0:00-99:59 , 100-9999
DISTANCE	0.00-9999 Mile/KM (display maximum of 2 decimal places)
CALORIES	0-9999 K-CAL
RPM	5-150
HEART RATE	35-255 bpm

## 7. OPERATE THE PRODUCT

### OPERATION Safe Operating Area

- (a) As shown below, the area marked in diagonal lines provides the use such as normal operation, machine adjustment and any emergency. For safety, DO NOT allow people of non-users enter this area while operating.
- (b) Noise emission under load is higher than without load.

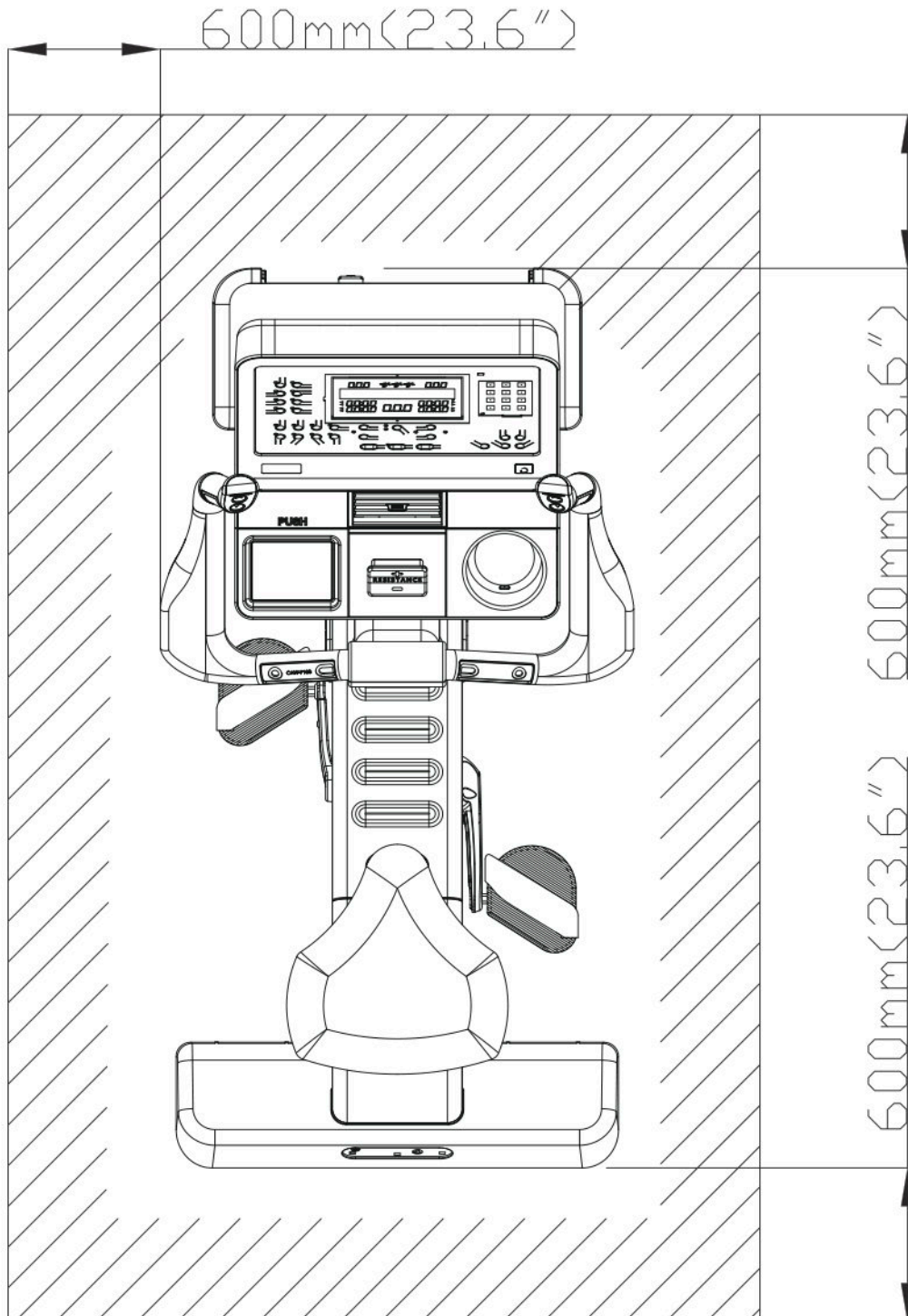

## **OPERATION**    **Operating position**

---

- (a) Please operate the bike with proper workout position, over exercise or improper workout position may result in serious injury.
- (b) You can put your hands on the handlebar to step on/off the bike from both sides.
- (c) The machine is mainly to train the muscles on your leg.

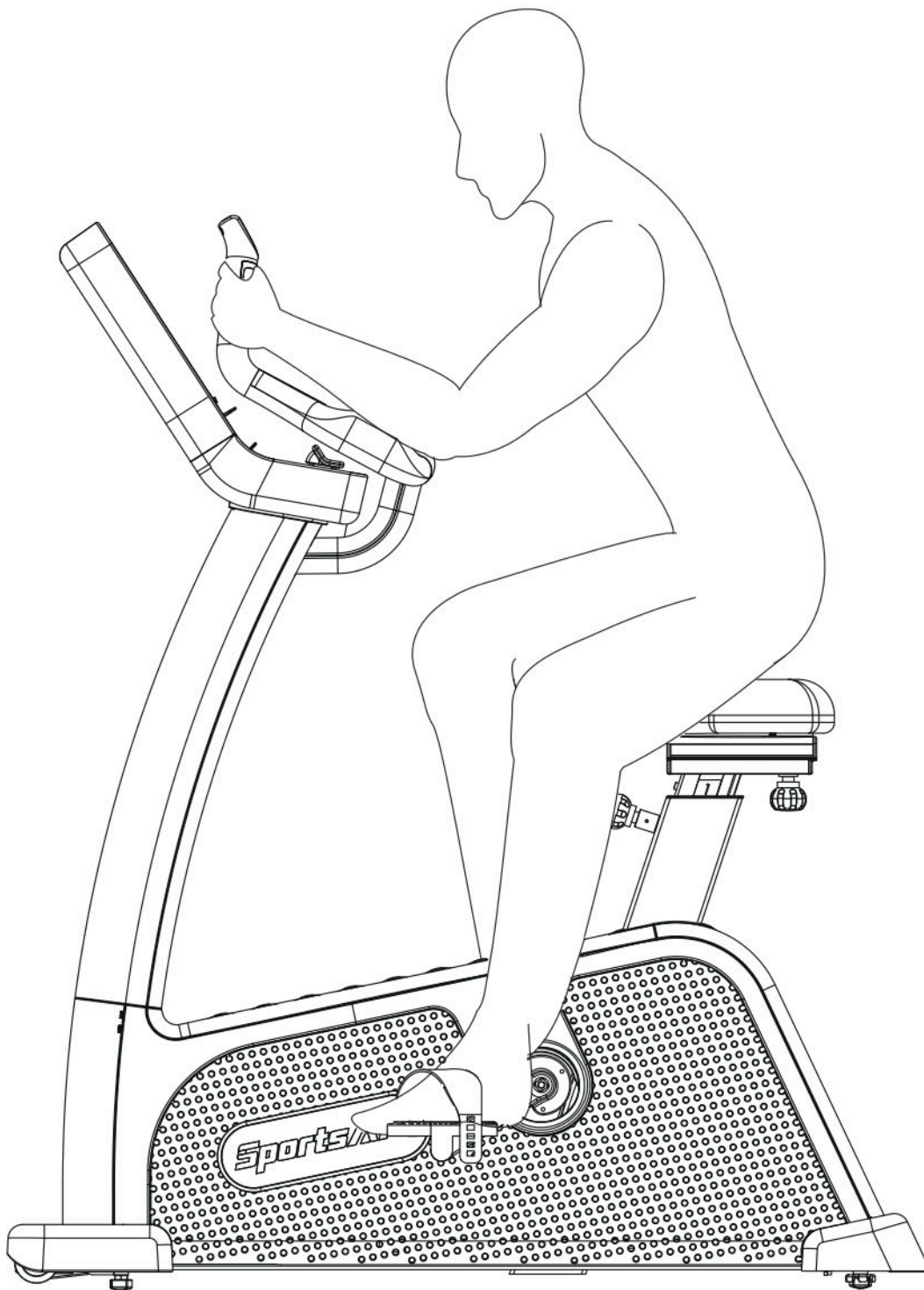

## **OPERATION**    **Step on/off the Bike**

---

Step on the bike: Sit in the seat, hold the handlebar, put your feet on the pedals to operate the bike. (Operation position is shown as below.)

Step off the bike: Slow down your movement and leave your feet off the pedals.

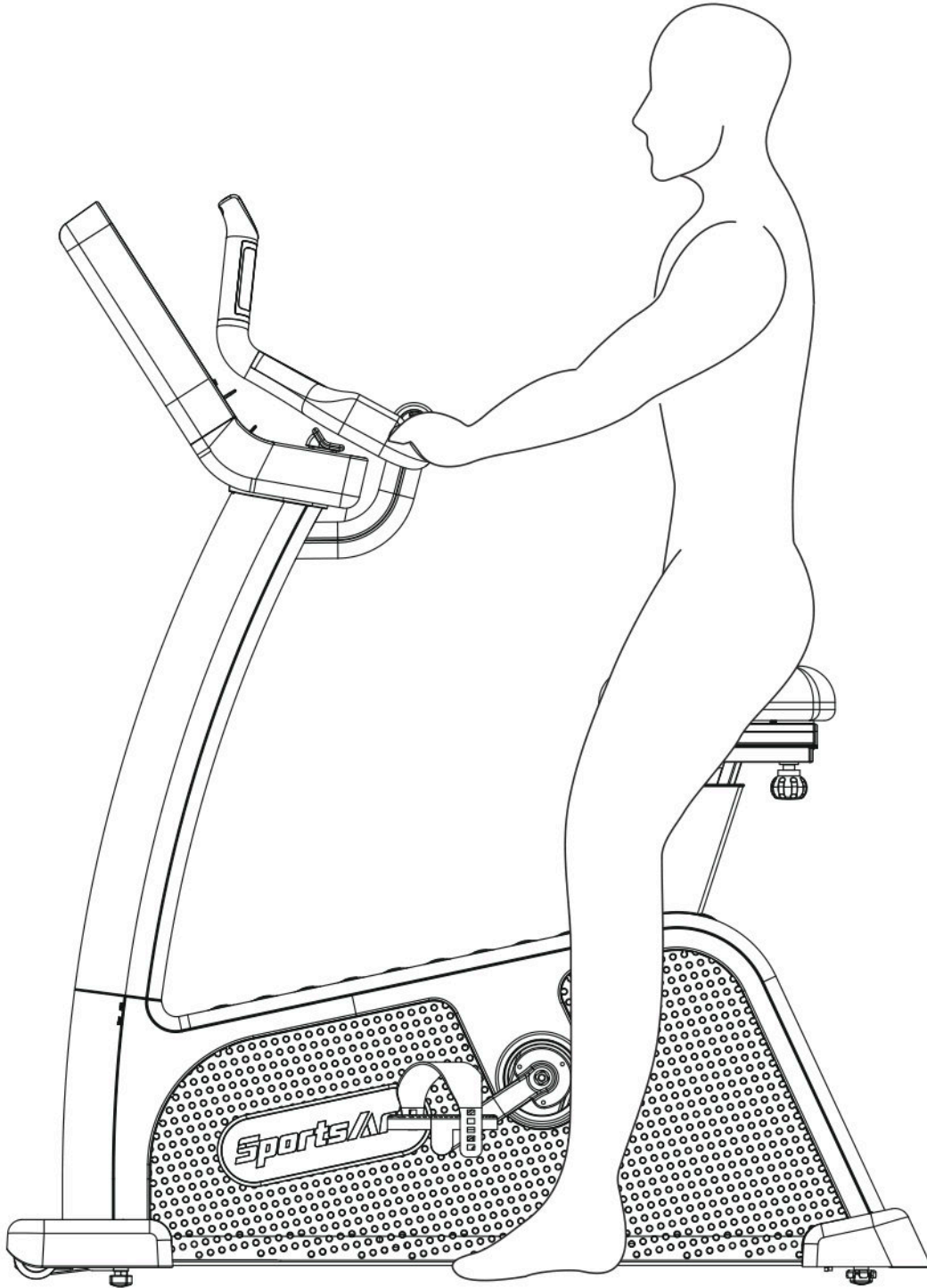

## **OPERATION** Start Screen

Press the wake button (at the bottom right of the panel) or step on the pedal to start the machine. After started, you will hear the BEEP sound and see the start screen.

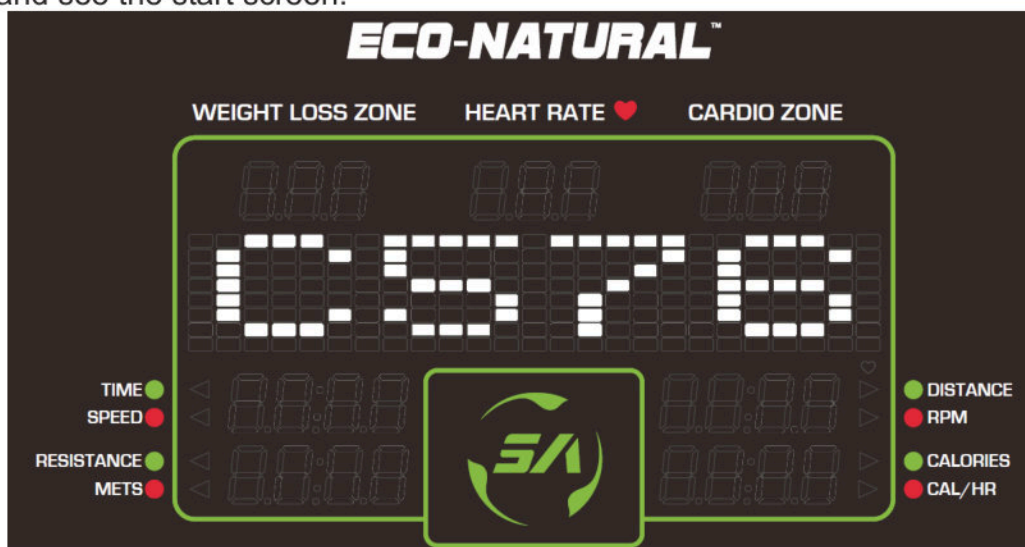

## **OPERATION** Quick Start

QUICK START key is preset based on user 35 years old and weighs 75 kilograms (165 pounds). The program is preset at manual, and the resistance is preset at 1.

## **OPERATION** User Setting Procedure

The bike measures your calories burned (based on weight), target heart rate (based on age), total time, and total distance based on your personal information that you have entered.

### 1. PROGRAM/GOAL Setting



(1) Select your desired program from PROGRAM menu and press <ENTER>, and then proceed to workout goal setting.

(2) Select your target goal from GOAL menu and press <ENTER>, and then proceed to set the goal values. (The program is preset at MANUAL)

### 2. WORKOUT GOAL Setting

After entered goal-setting, the words "SELECT GOAL" will pop up on the display. Select one of the following options to set as your target goal.

## OPERATION User Setting Procedure (Continued)

Pattern	Instruction
	Select <TIME> as your workout goal, the <TIME> button light will stay on and then proceed to time settings. The range is 5 - 300 minutes with the default of 30 minutes.
	Select <DISTANCE> as your workout goal, the <DISTANCE> button light will stay on and then proceed to distance settings. The range is 0.1 - 99.9 miles/kilometers with the default of 2.0 miles(3.0 kilometers).
	Select <CALORIES> as your workout goal, the <CALORIES> button light will stay on and then proceed to calories settings. The range is 100 - 9999 kCal with the default of 100 kCal.

### 3. Age and Weight Setting

(1) AGE : The range is 10 - 99 years old with the default of 35 years old.

a. Window Display:

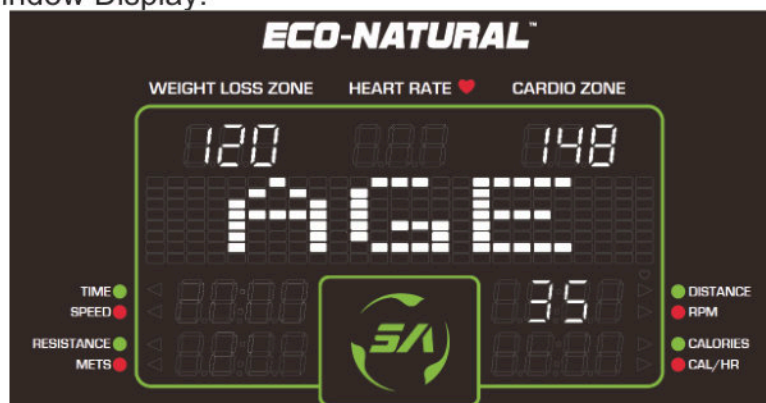

b. Press <RESISTANCE +/-> or number <0-9> to set your age.

c. Press <ENTER> to confirm and proceed to the weight settings.

d. You can also press <QUICK START> to start exercise directly with the preset workout values or the system default.

(2) WEIGHT : The range is 50-500 lb. (20-227 kg) with the default of 165 lb. / 75 kg.

a. Workout Data Display:

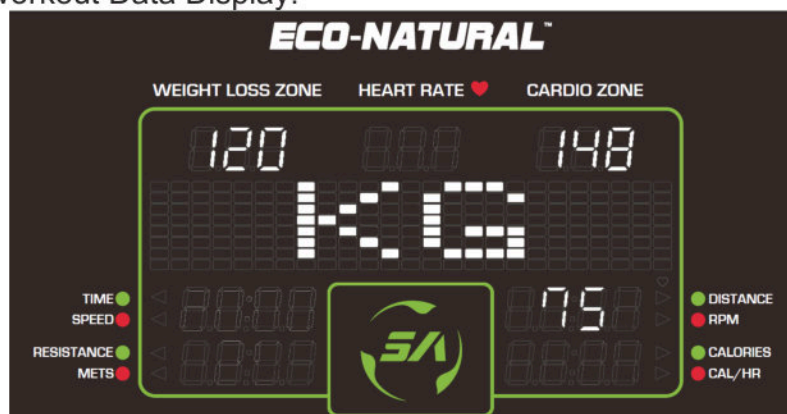

## **OPERATION** User Setting Procedure (Continued)

---

- b. Press <RESISTANCE +/-> or number <0–9> to set your weight.
- c. Press <ENTER> to confirm and enter PROGRAM settings.
- d. You can also press <QUICK START> to start exercise directly with the preset workout values or the system default.

## **OPERATION** Workout Programs

---

You can choose the desired program from the PROGRAM menu located at the bottom left corner of the display.

### **MANUAL:**

The general mode. The resistance can be adjusted according to your own preference.

### **INTERVAL:**

Regularly alternate between high-intensity and low-intensity exercises.

- (1) The program is a two-stage exercise (REST/WORK) and each has different parameters of the time and the resistance. According to the time ratio, there are three options in 1:1、1:2 and 2:2.  
(For example: “1 : 2” means one minute for resting and 2 minutes for workout.)
- (2) Since it is a two-stage training, you can change the REST resistance and memorize it when the program is executed, same as for WORK. Next time, when work to the corresponding segment, it will operate according to the last setting.

### **PLATEAU:**

This program is to simulate to workout on the plateau, the change in resistance is shown in the picture below. The first and the last segment each accounts for 20% of the workout. The middle segment accounts for 60% of the workout.

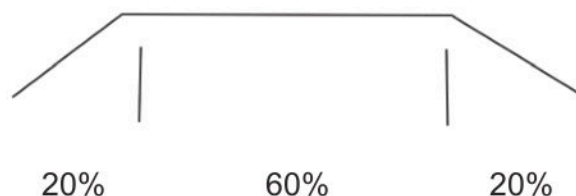

### **RANDOM:**

The graphic pattern in RANDOM PROGRAM are generated randomly, and the illustration shows differently each time.

## **OPERATION** Workout Programs (Continued)

### **FAT BURN:**

The FAT BURN mode provides the exercise mode to burn fat. According to the difficulty, there are 20 levels to choose from.

1. You need to set the level of the STAGE prior to get started, the range is 1 - 20, and the default is STAGE 5.
  - (1) The window will display the illustration of the 20 levels in different. The DISTANCE/RPM area displays the level of STAGE.
  - (2) Press <RESISTANCE +/-> or number <0-9> to set STAGE.
  - (3) Press <ENTER> to confirm and enter PROGRAM settings.
  - (4) You can also press <QUICK START> to start training directly with the last workout values or the system default.
  
2. Press <RESISTANCE +/-> to change the level of STAGE during exercise.

### **FIT TEST**

This program measures your fitness level using the default time goal and a few simple tests.

1. Start fitness testing after the words "STARTING TEST" pop up.
  2. This program has four parts, and each part will take 3 minutes to complete. The resistance in each part is variable and depends on your current speed.
  3. The recommended RPM is displayed as a dot at the top of the console, and your current speed is displayed as a wavy line at the bottom of the console. Try to match your current speed with the target speed.
  4. The pedal speed recommended in BIKE mode is 50±5 RPM. If the pedal speed is slower than 45 SPM / faster than 55 RPM for more than 5 sec., the words "MAINTAIN RPM-50" will pop up on the console.
- (1) The table below shows how the test process works.

Heart rate Stage	<80BPM	80-89BPM	90-100BPM	100BPM
1	25W	25W	25W	25W
2	125W (750kgm/min)	100W (600kgm/min)	75W (450kgm/min)	50W (300kgm/min)
3	150W (900kgm/min)	125W (750kgm/min)	100W (600kgm/min)	75W (450kgm/min)
4	175W (1050kgm/min)	150W (900kgm/min)	125W (750kgm/min)	100W (600kgm/min)
<b>NOTE</b>	If the heart rate is not in the range of $((220-\text{age}) \times 0.85 - 10)$ , proceed to stage 5, 6...and so on. Every stage will make the next take more load (+25W).			

## **OPERATION** Workout Programs (Continued)

---

- a. Each exercise stage lasts for 3 minutes.
- b. Tips for each exercise stage:
- Stage 1:** the default watt load is 25W, and the watt load for next stage depends on the heart rate measured at last 15 sec. of stage 1.  
For example, if the heart rate measured at last 15 sec. of stage 1 is 92bpm, then the watt load for stage 2 is 75W, 100W for stage 3, 125W for stage 4...and so on.
- Stage 2,3,4:** the watt load depends on the heart rate measured at last 15 sec. of the former stage. Subtract the heart rate measured at the 3rd. min. from the one measured at the 2nd. min. The value determines whether the exercise program continues or not, see details below:
- (a) If  $((220 - \text{age}) \times 0.85) - 10 < \text{heart rate} \leq 5 \text{ bpm}$ , the exercise ends.
- (b) If  $\text{heart rate} < ((220 - \text{age}) \times 0.85) - 10$ , and is less than 5bpm, the exercise continues to the next stage.
- (c) If  $\text{heart rate} > 5\text{bpm}$ , the exercise stage extends 1 min. and the heart rate will be measured again. Use the above formula and the calculated value to determine whether this exercise stage continues or ends.
- c. Everytime you enter a new exercise stage, the crosstrainer automatically adjusts your level based on your RPM to match the corresponding watt load. Take stage 2 for example, if the watt load is 100w and the RPM is 51, the crosstrainer will automatically adjust to level 7.

(2) Scoring:

A score is calculated based on user's VO<sub>2</sub>max, see the following table for details.

$$SM1 = (\text{Watt/kg in stage 2} \times 10.8) + 3.5 + 3.5$$

$$SM2 = (\text{Watt/kg in final stage} \times 10.8) + 3.5 + 3.5$$

$$HR1 = (\text{HR in the second to last min. of stage 2} + \text{HR in the last min. of stage 2}) / 2$$

$$HR2 = (\text{HR in the second to last min. of final stage} + \text{HR in the last min. of final stage}) / 2$$

$$b = (SM2 - SM1) / (HR2 - HR1) \text{ *note: "b" is for slope}$$

$$HR_{\text{max}} = (220 - \text{age})$$

$$VO2_{\text{MAX}} = SM2 + (b \times (HR_{\text{max}} - HR2))$$

**OPERATION** Workout Programs (Continued)

Percentile Values For Maximal Aerobic Power(ml.kg <sup>-1</sup> .min <sup>-1</sup> )--Men					
Percentile	Age				
	20-29	30-39	40-49	50-59	60+
90	51.4	50.4	48.2	45.3	42.5
80	48.2	46.8	44.1	41.0	38.1
70	46.8	44.6	41.8	38.5	35.3
60	44.2	42.4	39.9	36.7	33.6
50	42.5	41.0	38.1	35.2	31.8
40	41.0	38.9	36.7	33.8	30.2
30	39.5	37.4	35.1	32.3	28.7
20	37.1	35.4	33.0	30.2	26.5
10	34.5	32.5	30.9	28.0	23.1

Percentile Values For Maximal Aerobic Power(ml.kg <sup>-1</sup> .min <sup>-1</sup> )--Women					
Percentile	Age				
	20-29	30-39	40-49	50-59	60+
90	44.2	41.0	39.5	35.2	35.2
80	41.0	38.6	36.3	32.3	31.2
70	38.1	36.7	33.8	30.9	29.4
60	36.7	34.6	32.3	29.4	27.2
50	35.2	33.8	30.9	28.2	25.8
40	33.8	32.3	29.5	26.9	24.5
30	32.3	30.5	28.3	25.5	23.8
20	30.6	28.7	26.5	24.3	22.8
10	28.4	26.5	25.1	22.3	20.8

You will have a zero score if you haven't completed more than 3 stages in the process.

## **OPERATION** Workout Programs (Continued)

(3) The following is an example of calculating VO<sub>2</sub>MAX for a 40-year-old, 62kg male:

- a. The heart rate  $\geq ((220-\text{age}) \times 0.85) - 10$  in the last min. of stage 3. The exercise ends. The watt load and heart rate for each stage are presented in the following table.

Stage	WATT load	time(min)	HR(bpm)
1	25W	0-1	86
		1-2	90
		2-3	92
2	75W	3-4	120
		4-5	135
		5-6	139
3	100W	6-7	151
		7-8	159
		8-9	163

- b. Calculating VO<sub>2</sub>MAX and scoring:

$$SM1 = (75/62 \times 10.8) + 3.5 + 3.5 = 20.06 \text{ ml} \cdot \text{kg}^{-1} \cdot \text{min}^{-1}$$

$$SM2 = (100/62 \times 10.8) + 3.5 + 3.5 = 24.42 \text{ ml} \cdot \text{kg}^{-1} \cdot \text{min}^{-1}$$

$$HR1 = (135 + 139) / 2 = 137 \text{ bmp}$$

$$HR2 = (159 + 163) / 2 = 161 \text{ bmp}$$

$$b = (24.42 - 20.06) / (161 - 137) = 0.182$$

$$HR_{\text{max}} = (220 - 20) = 200$$

$$VO_{2\text{MAX}} = 24.42 + (0.18 \times (200 - 161)) = 31.5 \text{ ml} \cdot \text{kg}^{-1} \cdot \text{min}^{-1}$$

We use the VO<sub>2</sub>MAX table and find the corresponding score is 10.

5. End of exercise:

- Press the <STOP> key.
- Complete the entire cycle of the exercise process.
- Current heart rate  $> (220-\text{AGE}) \times 0.8$ , and lasting for 15 sec.
- No detectable heart rate for 30 sec.
- Heart rate  $< 45\text{RPM}$ , or heart rate  $> 55\text{RPM}$ , lasting for 15 sec.

6. The words "YOUR SCORE" will pop up, and your score is displayed at <DISTANCE>. 0 is the lowest possible score, and 100 is the highest.

## **OPERATION** Workout Programs (Continued)

---

### **CUSTOM HR / WT LOSS / CARDIO:**

The programs take control of resistance, keeping your heart rate within the target zone.

- (1) The target heart rate for each program is set as follows:
  - a. The user determine his/her target heart rate. The calculation does not take into account of his/her age.
  - b. In this program, the resistance changes automatically to maintain the target heart rate that is calculated by the formula  $(220-AGE) * 0.65$ .
  - c. In this program, the resistance changes automatically to maintain the target heart rate that is calculated by the formula  $(220-AGE) * 0.80$ .
- (2) If you choose CUSTOM HR, the target heart rate value will need to be set first. The range is 84-200 bpm with the default of 120 bpm.
- (3) During exercise, if the machine cannot read your heartbeat signal, it will display " NO HEART RATE READING , PLEASE CHECK TRANSMITTER" on your screen, and the resistance can be only adjusted manually.
- (4) Resistance will start at level 1, and the default is 50 RPM, your actual heartbeat is detected at all times.
- (5) During exercise, if the RPM is 5 revolutions below the recommended step rate for 25 seconds, the window will show the message "SPEED UP", please speed up your steps to return to the previous screen.

## **OPERATION** During Exercise

---

During exercise, you can switch to a different program using the same WORKOUT GOAL(TIME/DISTANCE/CALORIES) by pressing a different program key.

Please note it is not allowed to switch directly in the situation as below, and the window will display the message " SWITCHING NOT ALLOWED".

- (1) During MANUAL 、 INTERVAL 、 PLATEAU 、 RANDOM 、 FAT BURN 、 CUSTOM HR 、 WT LOSS 、 CARDIO program, it cannot be switched to FIT TEST program.
- (2) It is not allowed to switch to other programs during FIT TEST program.

## **OPERATION** Cool Down

---

Once the goal(TIME 、 DISTANCE 、 CALORIES) has been achieved, it will show the message" COOL DOWN " on your screen. The machine will enter a two-minute cool down period and count down from 2:00 to 0:00.

## OPERATION Stop Exercise

Press <STOP> during exercise, all the exercise data will stop accumulating and keep the current value.

## OPERATION Workout Summary

Press <STOP> or after cool down, it will show the message "REVIEW SUMMARY" and your current workout status on the screen lasting for 15 seconds, then press <STOP> once again to return to start screen.



## OPERATION Idle Mode

The machine will turn into power saving mode when there is no stepping on the pedal or not been operated to the buttons for 30 seconds, and the window will display "- - -" and continue to flash. To restart the machine, please step on the pedal or press any button to return to start screen.

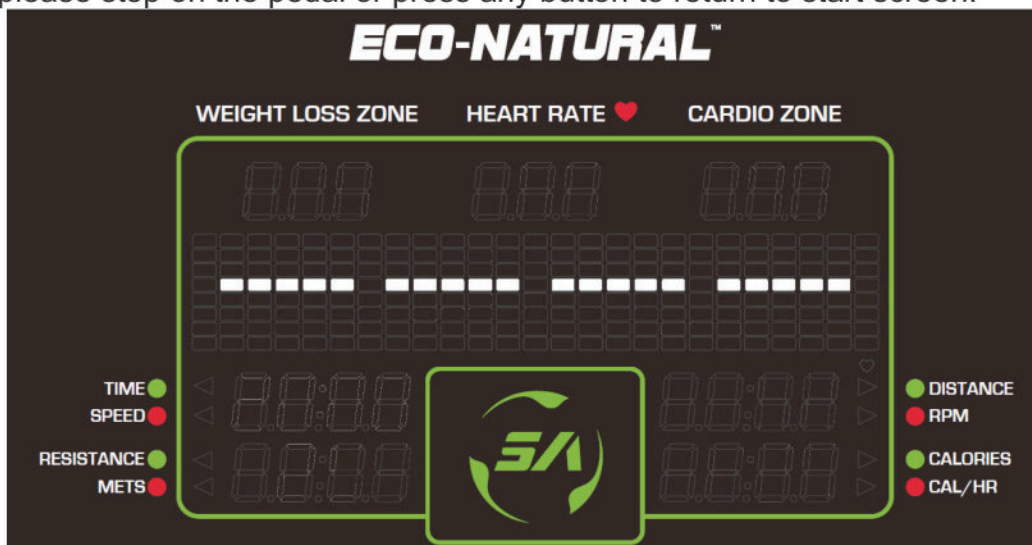

## OPERATION Energy Smart Function

The machine will shut off automatically when there is no stepping on the pedal or not been operated to the buttons for 2 minutes.

## **OPERATION** User Parameter Setting

Hold the <Change display > for 3 seconds to enter the user parameter setting procedures; press the <STOP> key at any time to return to the start screen.

Please refer to the following setting procedures:

### **(1) Metric System / Imperial Units Setting**

The window will display KPH or MPH, press <RESISTANCE +/–> to select the metric system or the imperial units, then press <ENTER > key to confirm your setting and go to the next step.

### **(2) Display the Program Version**

The window will show the version of each program, press <RESISTANCE +/–> to view each program version, then press <ENTER > and go to the next step.

Program Version Items:

- (a) CTL SA\_6 - xx → The program version of the control board.
- (b) DRV C575\_SG - xx → The program version of the drive board.
- (c) SA WELL+ x.x.x → The program version of the SA WELL+ adapter.  
(This function is only available if you purchase SA WELL+.)

### **(3) Display the Mileage**

The window will show the message of DIST- xxxxxx KM or DIST- xxxxxx MILE, press <ENTER > and go to the next step.

### **(4) Display the Total Time**

The window will show the message “TIME- xxxxxx HOURS”, press <ENTER > and go to the next step.

### **(5) Product Serial Number**

The Window will show the message of “S/N xxxxxxxx” (as shown below), press <ENTER > and go to the next step.

※ The number “1234567” in the picture represents the machine serial number.



## **OPERATION** User Parameter Setting (Continued)

---

### **(6) Language Setting**

The window will show the options of the countries, press <RESISTANCE +/-> key to select your language, then press <ENTER > to confirm and go to the next step.

### **(7) Time Limit Setting**

The window will show the message of "LIMIT", press <RESISTANCE +/-> key or numeric keypad to set the time, then press <ENTER > to confirm and go to the next step.

If the time limit is set less than 5 minutes, this function is deactivated. The setting range is 5-60 minutes.

### **(8) Turn on/off the Buzzer**

The window will show the message of "BZ", press <RESISTANCE +/-> key to turn on/off the buzzer, press <ENTER > to confirm and go back to the start screen.

## 8. ABOUT HEART RATE DETECTION

Heart rate detection functions are selected at the time of purchase. Not every product has every type of heart rate detection. The following explains factors that influence the performance of two of the most common types of heart rate detection devices.

### HEART RATE Telemetry

---

The words “telemetry heart rate” refer to the detection of heart rate via a device worn on the exerciser and transmitted over the air to a circuit board built into the product. Telemetry heart rate devices are commonly worn on the exerciser’s chest, where the pulse is strongest and relatively easy to detect.

The following explains conditions that affect the performance of the telemetry heart rate function in all products.

- The telemetry heart rate transmitter emits a wireless 5 kHz signal that is harmless to the human body. Keep a distance within 60cm between the heart rate receptor and the transmitter to achieve stable connection.
- If the battery is too low, the receiving distance may be shortened or there will be no reception.
- Secure the telemetry heart rate transmitter on your chest so that it stays in place without making you feel uncomfortable. Moisten the skin for better contact.
- Because the telemetry heart rate signal varies in strength from 20 Hz to 20 KHz, environmental interference can block signal reception. Physical vibration and electronic devices, including stereos, TVs, and even fluorescent lights, can interfere with signal reception. For best results, install the product in an area free from such interference.
- Space the product apart by at least 39 inches (100 cm) to avoid having the heart rate value from one exerciser appear on a neighboring product.

### HEART RATE Contact

---

The words “contact heart rate” refer to the detection of the heart rate via sensors on the product. By holding the sensors, the exerciser can view his or her heart rate on the product display. Like telemetry heart rate, contact heart rate can be influenced by several factors. The following list includes some of these factors.

- A weak pulse makes it difficult to detect heart rate.
- Low systolic blood pressure makes it difficult to detect heart rate.
- Dry, course palms impede heart rate detection. For best results, moisten your palms. But do not apply hand lotion immediately prior to your workout, because hand lotion can gum up the contact pads.

Heart rate devices built into this product are not medical devices. Heart rate values are for reference only. Do not use them for medical diagnostic or treatment work.

**CAUTION:** Heart rate detection and transmission devices have been known to interfere with the operation of pacemakers, possibly endangering human life. If you have a pacemaker, exercise under your doctor’s supervision; take a test to ensure your safety during the simultaneous use of the pacemaker and heart rate detection devices. The use of such devices must be undertaken at your own risk.

Note that in dry areas in particular, static electricity can interfere with unit operation and shock people. To discharge static electricity from your body, touch something else before touching metal on the product.

## 9. GUIDELINES FOR EXERCISE

### HOW HARD SHOULD I EXERCISE?

Studies show that to benefit from aerobic exercise, people need to maintain a certain heart rate during their workouts. Your heart rate training zone depends on your age and fitness level.

The darkened area in the chart to the right represents the recommended heart rate training zone for people of various ages. It was calculated by taking 220 minus age in years, multiplied by 65% and 80%. The area between those values is the heart rate training zone.

**CAUTION:** Heart rate training zones are generalizations and may not suit every person. Always check with your physician to understand what heart rate goal would be appropriate for you.

### HOW LONG SHOULD I EXERCISE?

The duration of your workout must depend on your fitness level. In general, it is recommended that you maintain a heart rate within your training zone for at least 15 to 20 minutes to experience the benefits of aerobic exercise. Beginners should always start out slowly and gradually increase the duration and intensity of their workouts. As your fitness level improves, you will be able to maintain a heart rate within the training zone for longer periods of time.

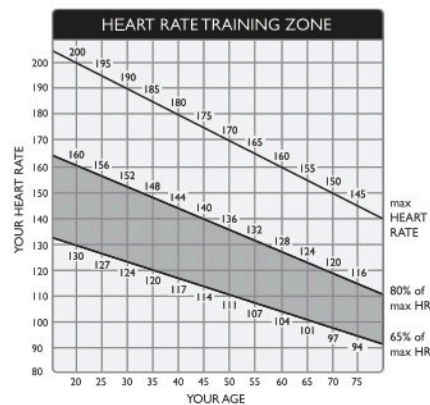

When you begin your workout, use the first several minutes to warm up. Then slowly increase the intensity of your workout to bring your heart rate into your training zone. At the end of your workout, gradually decrease your workload. Then exercise lightly to cool down.

### HOW OFTEN SHOULD I EXERCISE?

Research indicates that to achieve the greatest benefit, people should exercise three to five times per week. It is important to allow sufficient time, at least 24 hours, for your body to recover after exercise.

## 10. MAINTENANCE

This section covers maintenance topics, including instructions on replacing a fuse and lubricating the walk belt, along with the presentation of a maintenance schedule, maintenance task list, one-year maintenance log, and electronics block diagram.

### **MAINTENANCE** Safety Precautions

- Please follow standard safety precautions when servicing on this product.
- Electronic components can carry an electrical charge even after the product has been turned off. For safety, turn off unit power. Wait five minutes to allow capacitors to discharge. Then disconnect the power cord from the wall socket (if applicable.) Only after such steps have been completed should covers be removed and electronic components accessed.
- Unplug product and wait ten minutes before performing maintenance.
- Do NOT use a damp towel to clean the product and do perform the following maintenances.
- Do NOT use cleaners with alcohol, ammonia, or other damaging chemicals. The use of such chemicals can damage the product and void the warranty. Never spray or pour any liquid directly onto the product. Doing so can damage electronic components and void the warranty.
- Use a clean, lint-free towel, dampened with a mixture of Simple Green® all-purpose cleaner, to thoroughly clean the handlebar and the console.
- This product has moving parts that can be hazardous. Exercise caution when maintaining, operating, or moving this product.
- Do not use accessories or parts that are not specifically recommended by the manufacturer (SportsArt) . Such parts might cause injuries or cause the unit to fail and void the warranty. We will not be responsible for any safety issue that arises due to the misuse of accessories or parts. At the same time, we will terminate the warranty terms of this equipment.
- The treadmill shall be disconnected from its power source during service and when replacing parts.
- Maintenance and repair must be performed by trained service personnel only. Improper maintenance would not only damage the machine, but also may present a danger to the exerciser.
- Keep this product out of use until maintenance is completed.
- If you need to remove the cover for repair or maintenance, be sure to contact the service station or dealer to deal with, do not operate on their own.

## MAINTENANCE Error Messages

The window will show the error message when an unusual situation occurs on the machine.

(Shown as illustration below, X is for the main code, Y is for the secondary code.)



Error Code Description:

Main Code X	Secondary Code Y	Error message	Note
8	1	When start up, communication with the drive board is abnormal.	Will restore when the communication is back to normal.
8	2	When start up, communication with the driver board is normal, but an abnormality occurs during use.	Will restore when the communication is back to normal.

## MAINTENANCE Schedule

	Area	Day	Week	Month	Quarter	Year	Notes
1	Exterior	•					Clean.
2	Screws	•					Inspect the looseness and fix
3	Seat	•					Clean with slightly damp wiper
4	Pedals	•					Inspect the looseness and fix.

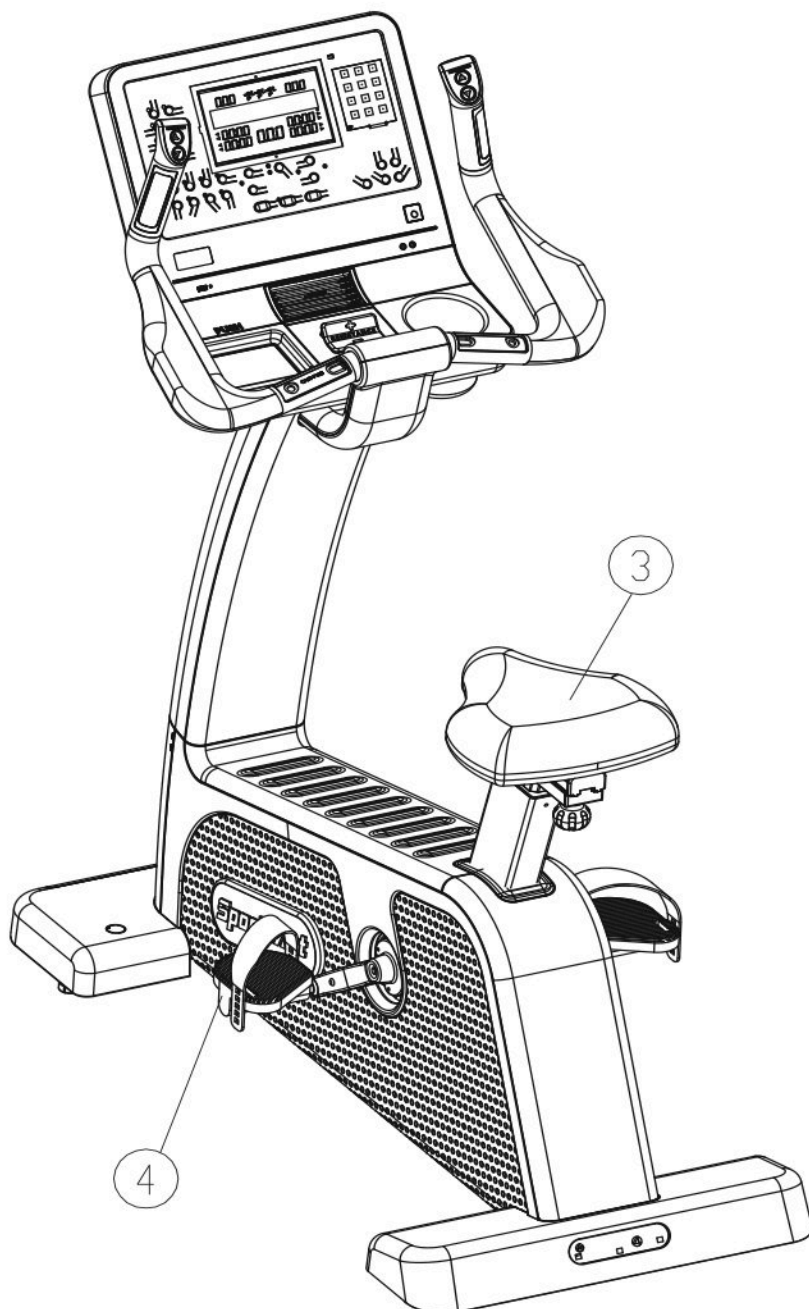

## 11. ACCESSORIES

### ACCESSORIES Standard

#### USB CHARGER

The USB port provides up to 5V, 1A of power for charging.

#### CSAFE PORT

Compatible with CSAFE (Communications Specification for Fitness Equipment) Protocol.

To support MYE Wireless TV Audio\_Channel Receiver, and the other equipment that conform to the CSAFE specification.

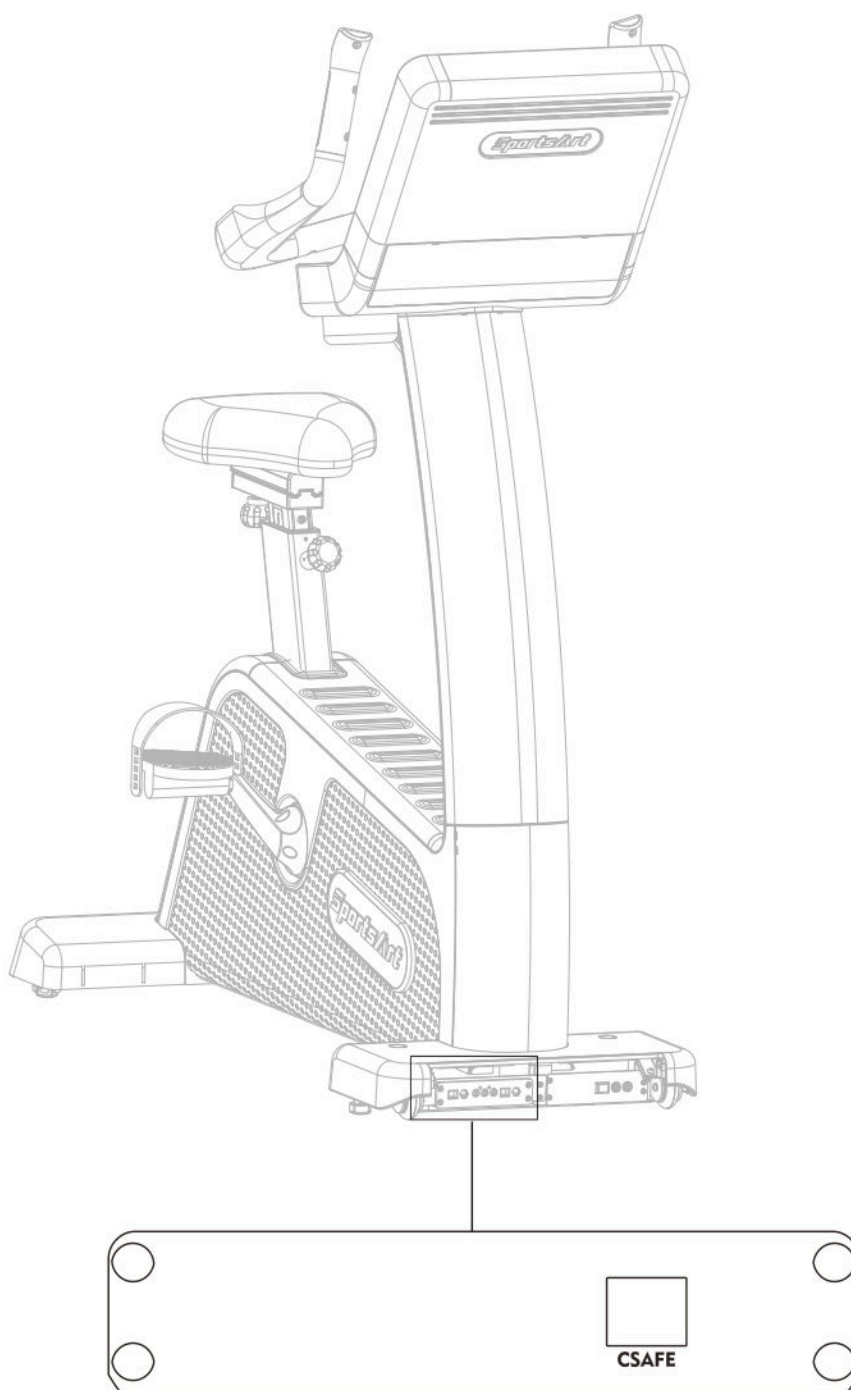

## ACCESSORIES Option

### SA WELL+ Member System

This is designed specially by SportsArt to assist the user in managing their workout history. There are three ways to get connected with the member site:

1. Using a smartphone, connect to the unit via Bluetooth/WIFI and use the SA WELL+ App. The App is available for download in the App Store and Google Play.
2. Use USB Flash Drive to store the workout data.
3. Manage user information and workout data

Visit “[www.gosportsart.com](http://www.gosportsart.com)” for more information about this feature.



No.	Name of button	Function
a	USB port	This port is used for optional data transferring.
b	Bluetooth/WIFI button	When a smart phone is connected wirelessly to the treadmill, press this button to disconnect. Scan the QR code or tap the NFC tag on the console to connect to the equipment again.

**ACCESSORIES** Option (Continued)

---

1: External TV Mount

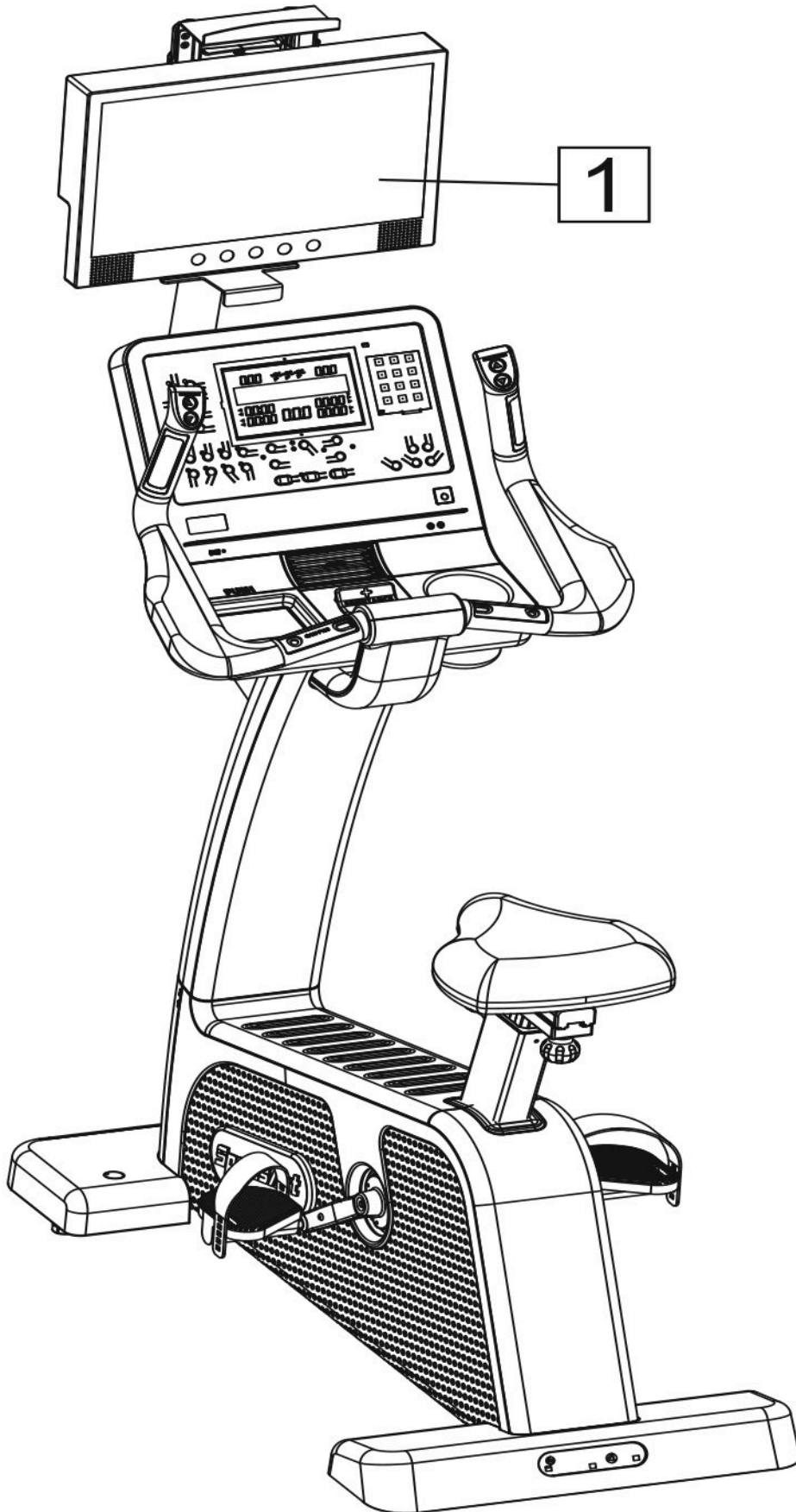

## **ACCESSORIES MYE Wireless TV Audio\_Channel Receivers**

[To purchase, please contact MYE Inc. <http://www.myclubtv.com/>]

Multiple TV and audio channels receiving and volume adjustment enabled.

- The following two modules are available for this receiver (to be purchased by client):
  1. MC3R-9(900MHZ), which has to be used with a MYE Wireless TV Digital Audio Channel Transmitter MWTD-S9.
  2. MC3R-8(863MHZ), which has to be used with a MYE Wireless TV Digital Audio Channel transmitter MWTD-S8.

Choose a suitable module according to country of location. (Please contact

MYE Inc. for detail specification and technical information)

For example: Wireless TV transmission frequency in America is 900MHZ.

Wireless TV transmission frequency in Europe is mostly 863MHZ (or nominally 800MHZ).

- Operation instruction: Turn off treadmill power, plug the receiver into the CSAFE port located at left of display and then turn on the power.
- The VOLUME +/- keys and CHANNEL ▲/▼ keys will be activated once the receiver is plug into the unit.

Press VOLUME +/- keys to adjust volume settings. The volume setting range is from 0 to 15, with a default setting of 5.

Press CHANNEL ▲/▼ keys to change channel settings. The channel

set

ting range is from 1 to 32, with a default setting of 1. The display will

show

“CH XX” during setting.

- Note: Do not unplug the receiver from unit before turning off the power to avoid receiver being damaged.
- The following is a schematic diagram of the connection:

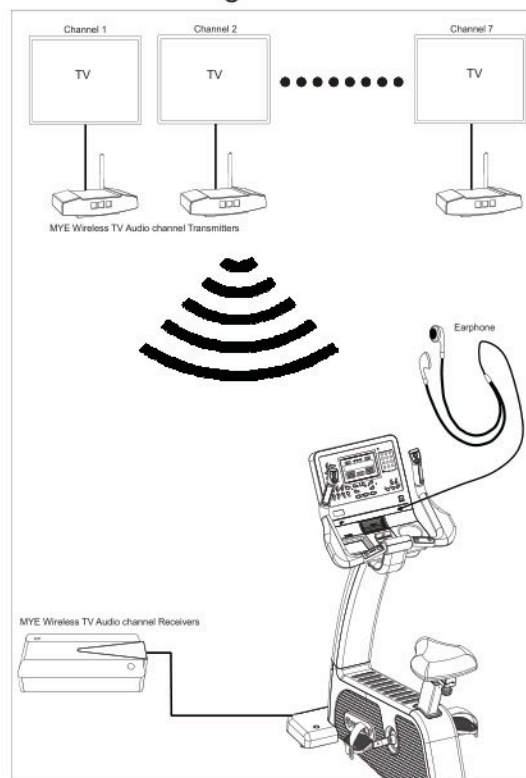

## 12. APPENDIXES

### APPENDIX Specifications

Model	C576U
Dimensions	L : 1260 mm (49.6") W : 685 mm (26.9") H : 1491 mm (58.7")
Overall Weight	101 kg (222 lbs)
Maximum User Weight	150 kg (330 lbs)
Power Requirement	DC 12V 4.0 Ah
Braking System	Adjustable

# APPENDIX Electronics Block Diagram

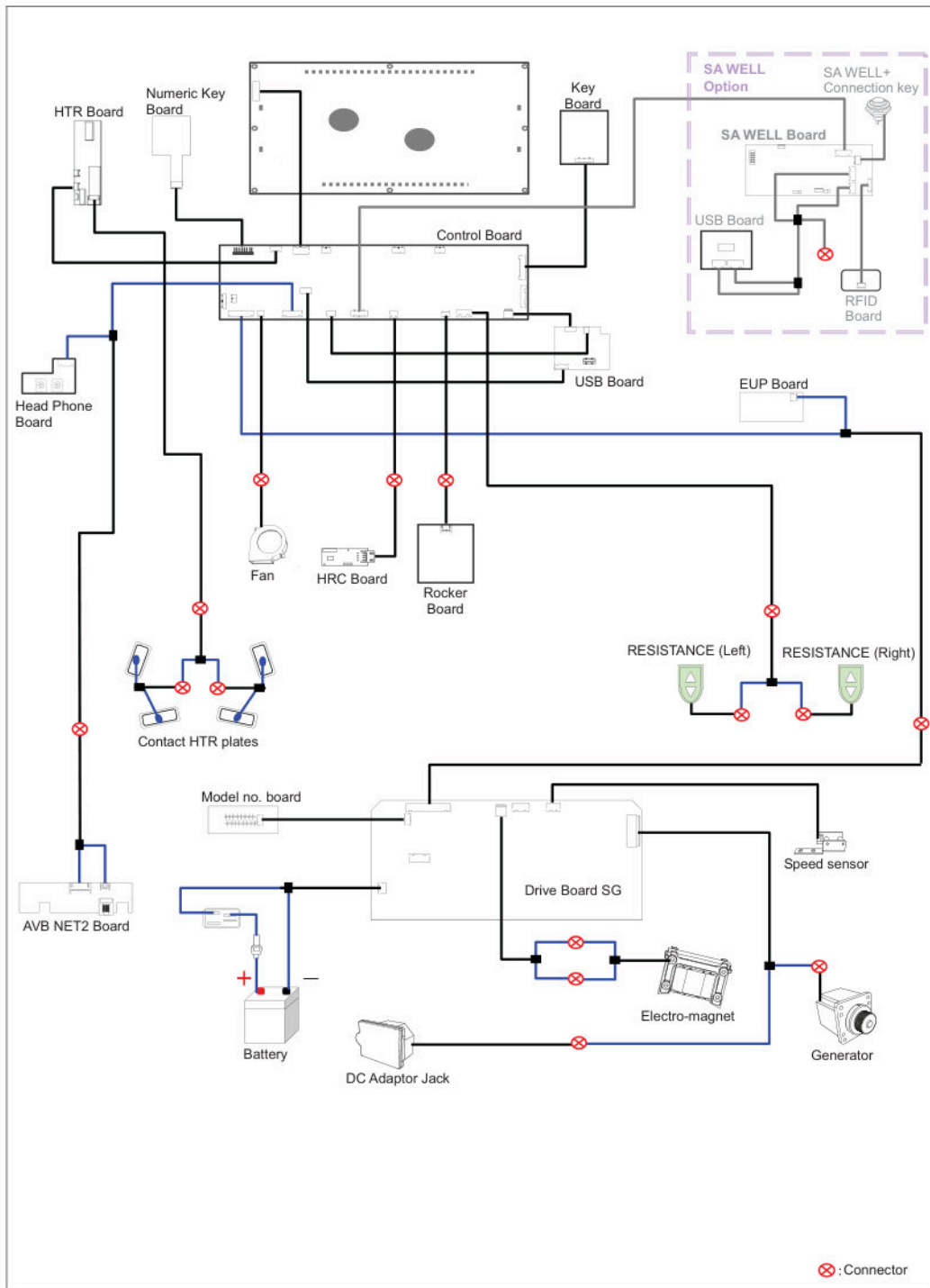

# APPENDIX Exploded Diagrams

CHANGE DATE	CHANGE DESCRIPTION	CHANGE NO.	NAME	<b>SportsArt</b> FITNESS RESTRICTED USAGE, PLEASE DON'T FORWARD TO ANOTHER MANUFACTURER	DRAWN BY	UNITS	SALES BLDG UP	Diagram NO.
					VERIFIED BY	QTY	XX	MODEL
					VERSION			
					PART NO.			



## APPENDIX Disassembly

(a) RESISTANCE Select Area

(b) Main Frame

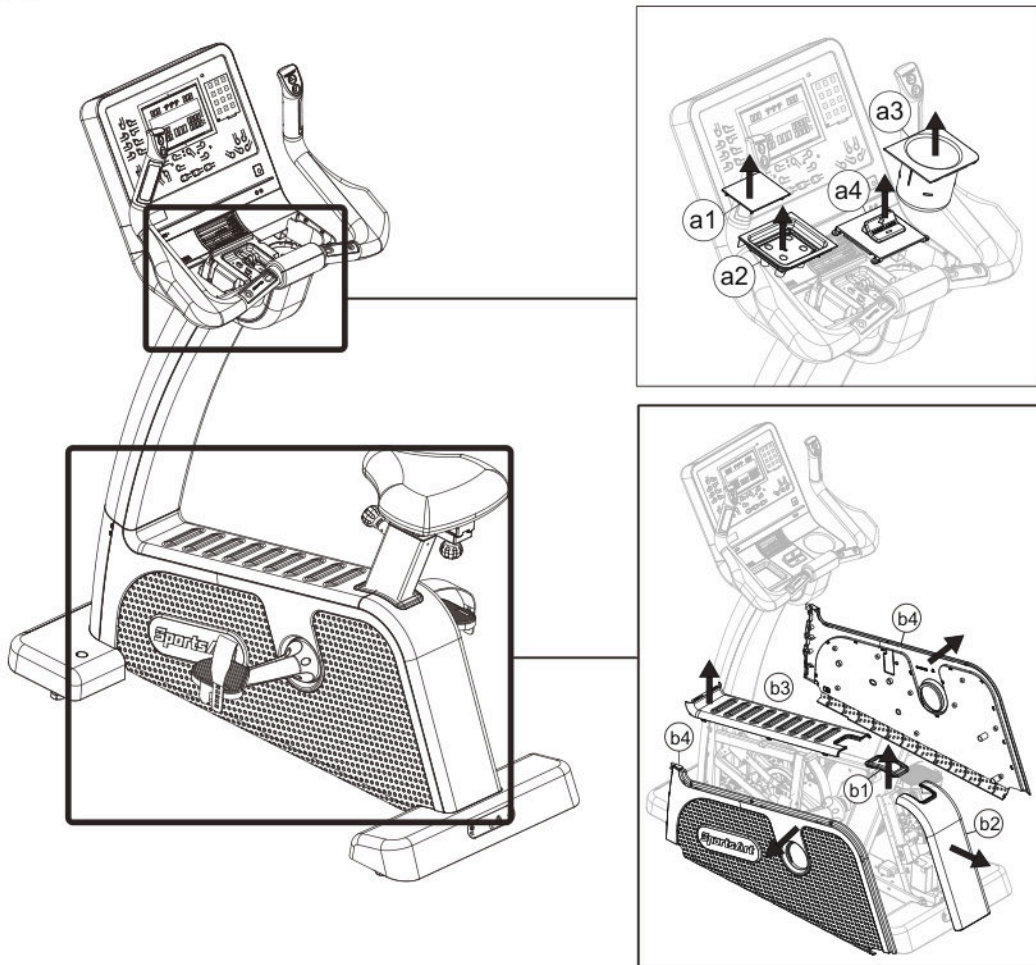

## APPENDIX Disassembly (Continued)

(c) Console

(d) Console Mast

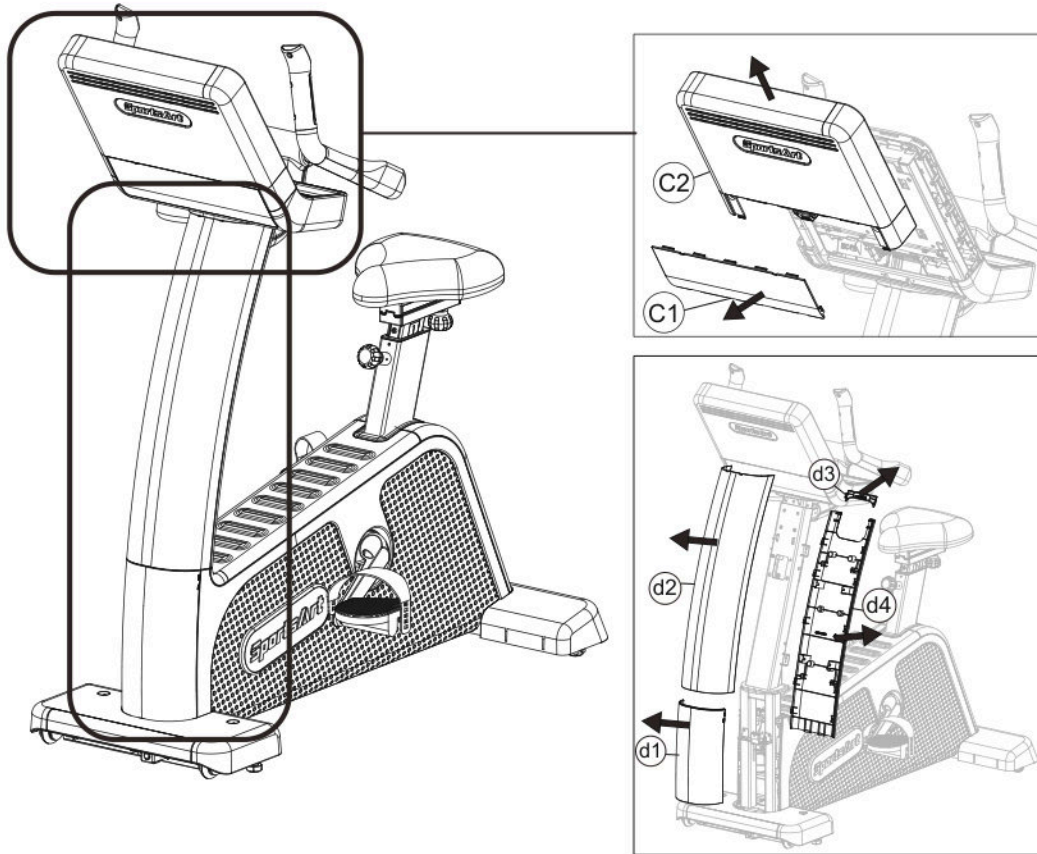

**Your Authorized Distributor**