

DF-300 OWNER'S MANUAL CONTENTS

1. INTRODUCTION	2
2. SAFETY PRECAUTIONS	3
3. LIST OF PARTS	4
4. ASSEMBLE THE PRODUCT	10
STEP 1 Cover Support Plate and the Connector Installation	10
STEP 2 Weight Stack Installation	14
STEP 3 Apply the Weight Stack Sticker	18
STEP 4 CAM Installation	19
STEP 5 Cable Installation	22
STEP 6 Floating Pulley Installation	26
STEP 7 Finger Guard Installation	27
STEP 8 Cylindrical Cushion Arm Installation	28
STEP 9 Upper Cable Adjustment	29
STEP 10 Lower Cable Adjustment	30
STEP 11 Upper Cushion Arm Installation	31
STEP 12 Seat Bottom and Seat Back Installation	32
STEP 13 Covers Installation	34
STEP 14 Install Plastic Cover	38
STEP 15 Install Cap Nut	39
STEP 16 Secure the Product	40
STEP 17 Level the Product	41
STEP 18 Stack Fork Inspections	42
STEP 19 Unit Inspection	43
5. OPERATION INSTRUCTION	44
OPERATION Operating the Product	44
OPERATION Exercising Instructions	48
OPERATION Safety Operating Area	49
6. MAINTENANCE	50
MAINTENANCE Safety Precautions	50
MAINTENANCE Guide Rod Cleaning and Lubricating	51
MAINTENANCE Schedule	52
MAINTENANCE Task List	53
MAINTENANCE One-Year Maintenance Log	54
7. CONSIGNES DE SÉCURITÉ IMPORTANTES	55
8. APPENDIXES	56

Disclaimer

The information in this user manual is subject to change without prior notice.

Sports Art Industrial Co., Ltd. makes no representation or warranty of any kind, express or implied, regarding the marketability of this manual, the suitability for a special purpose, or any other matters.

SportsArt Industrial Co., Ltd. accepts no responsibility for any errors in this manual, or any damages incurred directly, indirectly, accidentally, or continually from the modification, display, or other use of this manual.

*We reserve the right to revise this manual at any time without notice.

1. INTRODUCTION

Congratulations on the purchase of a high quality SportsArt product, the DF-300 Leg Extension / Leg Curl machine. Constructed of high quality materials and designed for years of reliable performance, this product was made for full commercial use.

Before this product is assembled or operated, we recommend that you familiarize yourself with this manual. Understanding the correct assembly and operation of this product will help ensure that exercisers obtain their fitness goals safely and successfully.

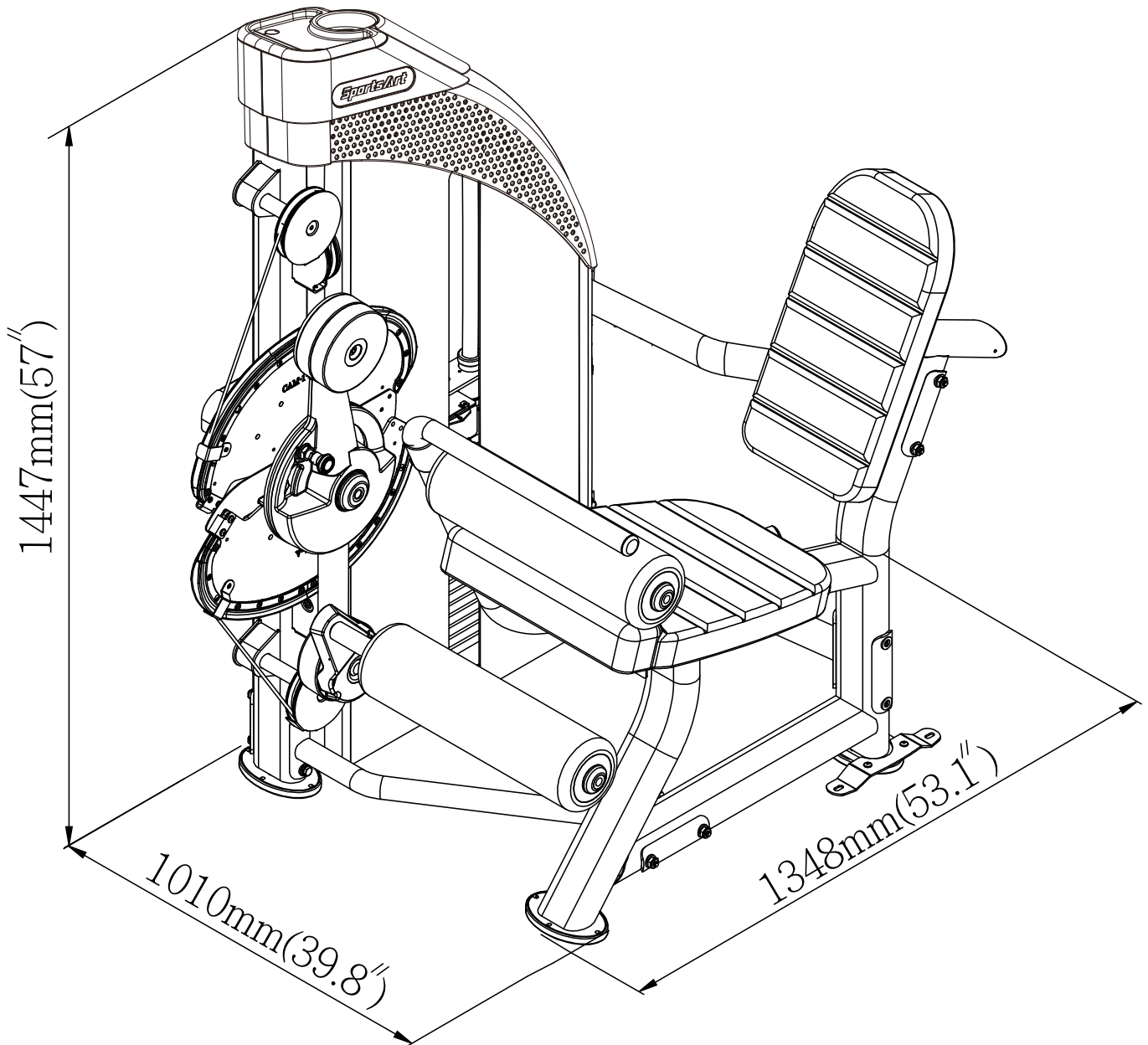

2. SAFETY PRECAUTIONS

This product was designed and built for optimum safety. However certain precautions apply during the use of this product. Please note the following safety precautions:

- Please read the entire manual before assembly and operation. Make sure the product is installed and operated as instructed in this manual.
- Assemble and operate the product on a solid, level surface. Do not use outdoors or near water, including pools and saunas.
- Check the product before every use. Make sure all parts are assembled, and all fasteners are tightened. Do not use the product if it is disassembled in any way.
- Wear proper workout clothing. Do not wear loose clothing. Do not wear shoes with leather soles or high heels. Tie all long hair back. Do not go barefoot on this product.
- Keep away from moving parts. Moving parts may or may not stop immediately if an object becomes caught or impedes normal motion.
- Use this product only for its intended purpose as described in this manual.
- Be careful when mounting and dismounting the unit.
- Never operate this product if it has been damaged in any way. If it is not working properly, or has been dropped or damaged, contact a service technician for repairs.
- Do not use accessories or parts that are not specifically recommended by the manufacturer (SportsArt). Such parts might cause injuries or cause the unit to fail and void the warranty. We are not responsible for any safety issue that arises due to the misuse of accessories or parts. At the same time, we will terminate the warranty terms of this equipment.
- This product is not intended for use by persons (including children 12 or younger) with reduced physical, sensory, or mental capabilities, or by people who are otherwise deficient in product knowledge or experience. If such people use this product, they should be given training and be supervised at all times by someone responsible for their safety.
- Contact your SportsArt representatives on all materials damaged in shipment. (Note: Shipping damages are the responsibility of the carrier.)
- Unpack and verify contents of boxes according to the list of parts to check if any parts are missing.
- Children 12 or younger should be supervised to ensure that they do not play on or near the product.
- The user weight limit for this product is 227 kg, 500 lb.
- Maintenance and repair must be performed by trained service personnel only. Improper maintenance would not only damage the machine, but may also present a danger to the exerciser.
- Over exercise may result in serious injury or death
- Warning that any of the adjustment devices that could interfere with the user's movement should not be left projecting.

CAUTION: If you feel any pain or any abnormal sensations, STOP YOUR WORKOUT and consult your physician immediately. Work within your recommended exercise level. DO NOT work to exhaustion. Before beginning any exercise program, you should consult with your doctor. It is recommended that you undergo a complete physical examination.

*NOTE: Each machine provides a different resistance ratio of weight stack.

3. LIST OF PARTS

Box A

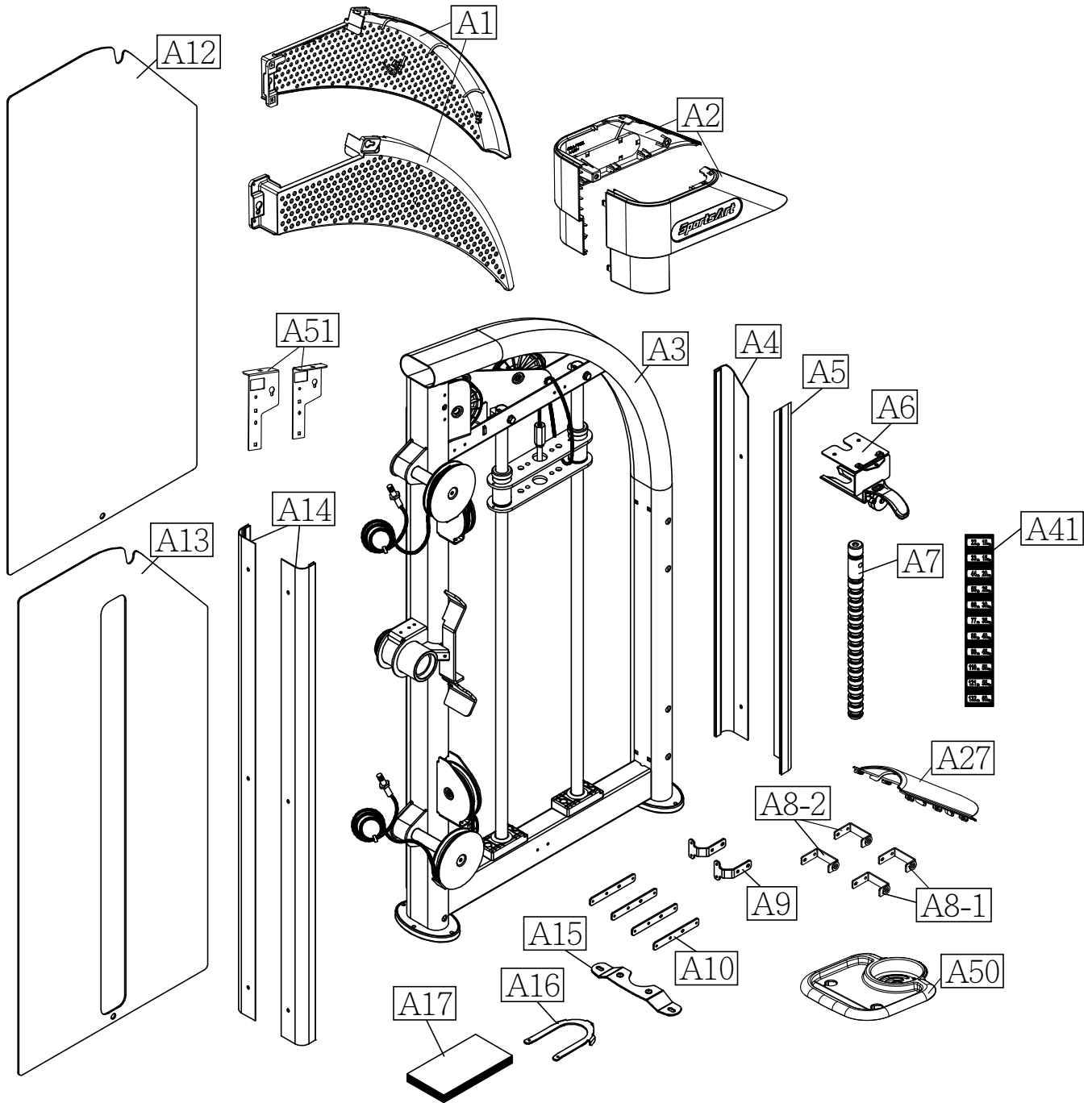

Box B

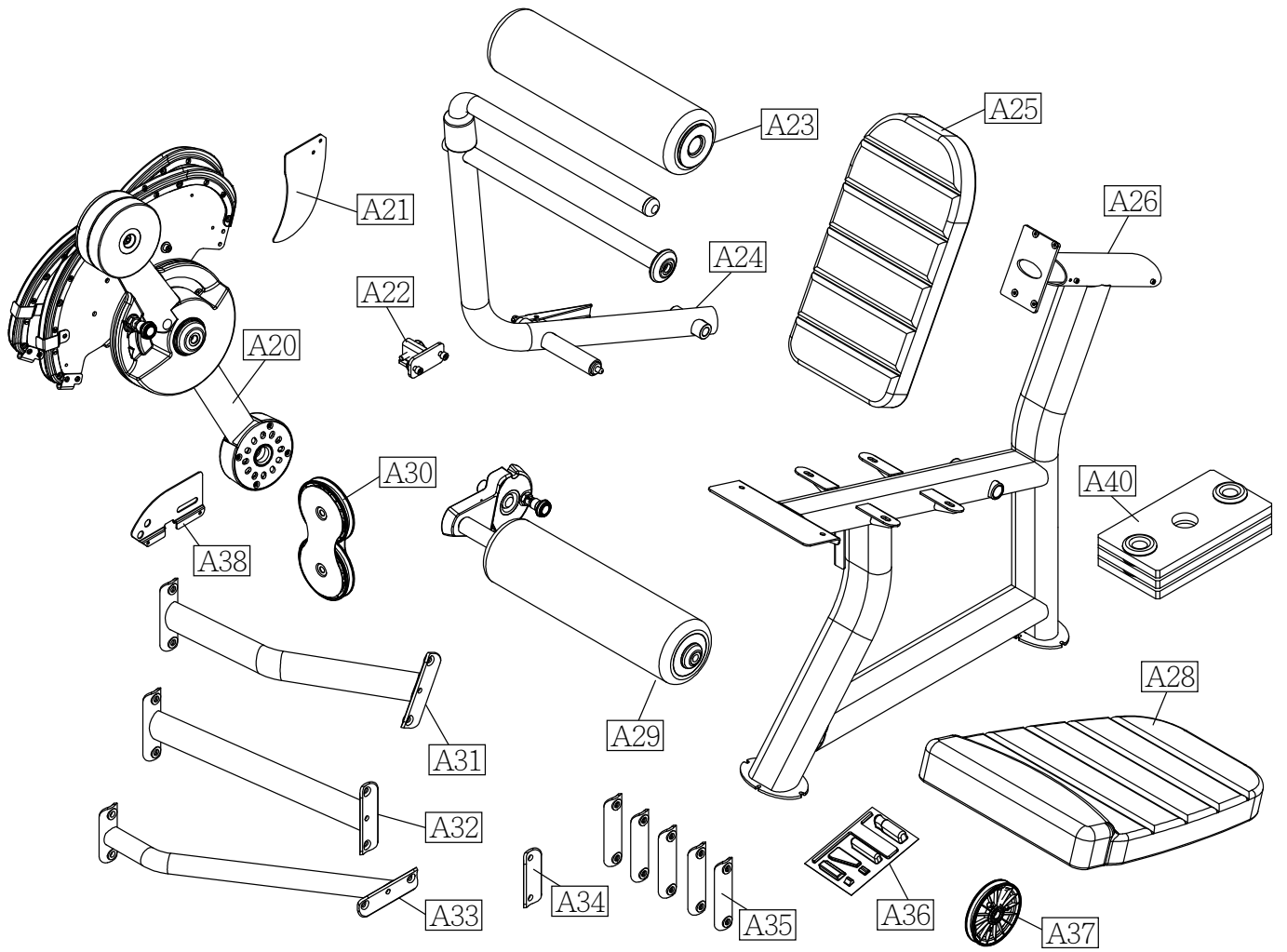

Box C

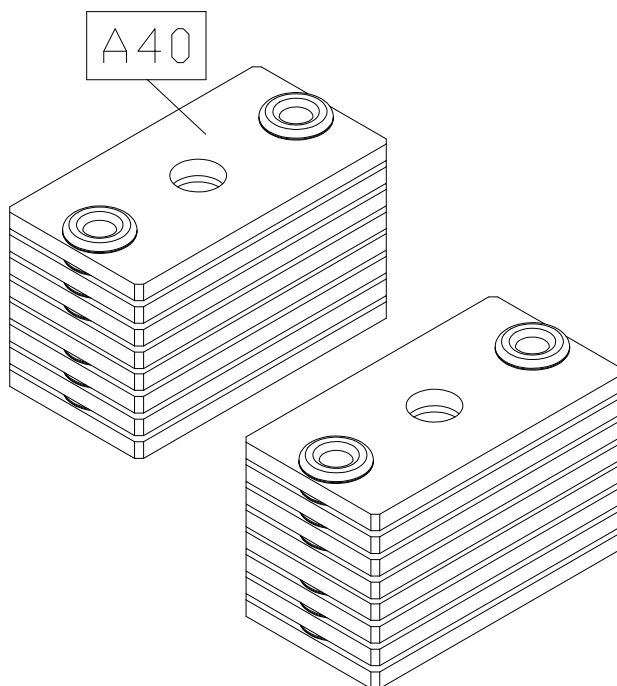

Box A - Main Frame Components					
No.	Name	Qty.	No.	Name	Qty.
A1	Left/right perforated boards	2	A12	Rear cover	1
A2	Left/right side cover	2	A13	Front cover	1
A3	Main frame	1	A14	Cover support plate A	2
A4	Cover support plate B-2	1	A15	Floor fixing bracket	1
A5	Cover support plate B-1	1	A16	U bracket	1
A6	Stack fork	1	A17	Owner's manual	1
A7	Weight stack rod	1	A27	Front cover A	1
A8-1	Anchor bracket of shroud (square hole)	2	A41	Weight plate sticker	1
A8-2	Anchor bracket of shroud (tapped hole)	2	A50	Top cover	1
A9	Bracket	2	A51	Anchor bracket	2
A10	Bracket	4			

Box B - User Frame Components					
No.	Name	Qty.	No.	Name	Qty.
A20	CAM	1	A31	Connector A	1
A21	Finger guard	1	A32	Connector B	1
A22	Stopper A	1	A33	Connector C	1
A23	Cylindrical cushion	1	A34	Ø50 Connecting board A	1
A24	Upper cushion arm	1	A35	Ø50 Connecting board	5
A25	Seat back	1	A36	Hardware kit	1
A26	Seat frame	1	A37	Pulley	1
A28	Seat bottom	1	A38	Finger guard A	1
A29	Cylindrical cushion arm	1	A40	5kg/11lb weight plate	3
A30	Floating pulley	1			

Box C - Weight Plates Components					
No.	Name	Qty.	No.	Name	Qty.
A40	5kg/11lb weight plate	16			

Components in the Hardware Kit				
No.	Name	Qty.	Specification	Notes
15	Mushroom top inner hex screw	12	M6*P1.0*L12	
16	Mushroom top Phillips screw	8	M5*L15	
17	Screw socket	1 batch	SGN-07	
18	Mushroom top Phillips screw	10	M5*0.8*L8	
19	Round sticker	1		
20	Soft cap	1		
25	Hex head screw	12	M10*P1.5*L130	
	Spring washer	12	M10	
	Washer	24	D16*d10.2*t1.0	
	Nylon hex lock nut	12	M10	
	L-shaped Allen wrench	1	M4*L60mm	
	L-shaped Allen wrench	1	M5*L114mm*W24	
	L-shaped Allen wrench	1	M6*L120mm*W28	
	T-shaped Allen wrench	1	M4*L100	
	Double open end wrench	1	8mm*10mm	
	Screwdriver shank	1	Phillips and flat	
	Double open end wrench	2	13*17	
70	Phillips pan head sheet metal screw	6	M4*L12	
71	Phillips Umbrella head sheet metal screws	2	M4*L14	
72	Round screw cap	2		
73	Fastener	1batch		
	Cap nut	1batch		

Components on the Product			
No.	Name	Specification	Notes
32	Upper stack carriage set		
33	Hex head screw	M8*P1.25*L65	
	Washer	D17*d8.3*t2	
	PU tube	ØD12*d8*L51	
	Nylon hex lock nut	M8	
34	Hex head screw	M8*P1.25*L65	
	Washer	D17*d8.3*t2	
	PU tube	ØD12*d8*L82	
	Nylon hex lock nut	M8	
35	Guide rod		
36	Inner hex screw	M8*P1.25*L18	
	Spring washer	M8*t2.0	
	Washer	D17*d8*t1.5	

Components on the Product			
No.	Name	Specification	Notes
37	Inner hex screw	M8*P1.25*L20	
38	Axle cover	Ø65	
40	Mushroom top inner hex screw	M6*P1.0*L12	
	Spring washer	M6	
	Flat washer	D20*d6.3*t1.5	
41	Pulley bracket		
42	CAM stop plate		
43	Mushroom top inner hex screw	M6*P1.0*L10	
44	Cable set block		
45	Mushroom top inner hex screw	M6*P1.0*L20	
	Spring washer	M6	
	Nylon hex lock nut	M6	
46	Mushroom top inner hex screw	M6*P1.0*L12	
	Spring washer	M6	
	Flat washer	D20*d6.3*t1.5	
	Axle	ØD15*L24	
	Pulley	ØD126*20	
47	Nylon hex lock nut	M8*P1.25	
	Flat washer	D20*d8*t2.0	
	Inner hex screw	M8*P1.25*L25	
48	Nylon hex lock nut	M6*P1.0*6	
	Flat washer	D16*d6.3*t2	
	Mushroom top inner hex screw	M6*P1.0*L20	
50	Axle cover	Ø50	
51	Inner hex screw	M8*P1.25*L30	
52	Inner hex screw	M8*P1.25*L20	
53	Mushroom top inner hex screw	M8*P1.25*L25	
	Spring washer	M8	
	Washer	D22*d8.2*t2	
54	Seat back plate		
55	Inner hex screw	M8*P1.25*L20	
	Flat washer	D17*d8.3*t2	
56	Mushroom top Phillips screw	M5*0.8*L15	
	Flat washer	D13*d6*t1.0	
57	Inner hex screw	M5*P0.8*L10	
58	Set fork		
59	Bolt assy. crossover		
60	Spring washer	M6*t1.5	
	Mushroom top inner hex screw	M6*P1.0*L10	
61	Mushroom top inner hex screw	M6*P1.0*L12	

Components on the Product			
No.	Name	Specification	Notes
65	Reinforcement plate		
	Anchor bracket		
	Umbrella hex screw	M6*P1.0*L20	
	Plastic cover		
66	Umbrella hex screw	M6*P1.0*L12	

4. ASSEMBLE THE PRODUCT

Follow instructions below to assemble this product. Note that in this manual the words “left” and “right” are used to refer to the product and its parts. As such, these designations correspond to the “left” and “right” sides of a person in position to exercise on this product. Also, for brevity, the word “screws” or “nuts” is used where washers and other hardware may be involved.

STEP 1 Cover Support Plate and the Connector Installation

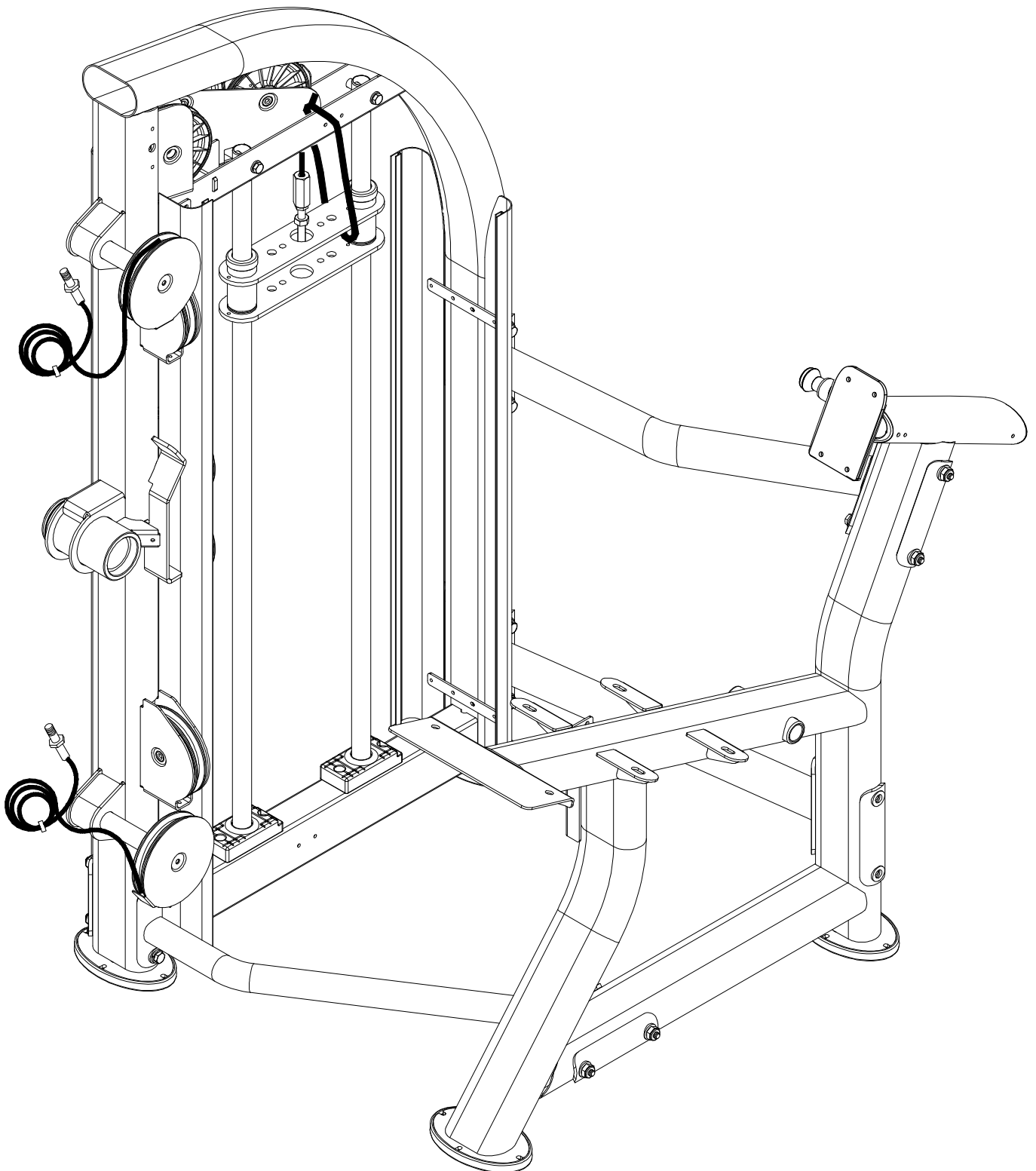

STEP 1 Cover Support Plate and Connector Installation (CONT.)

(a) Insert the screw sockets (17) into place in the main frame (A3) as shown, and then use screws (15) (16) to secure the brackets (A9) (A10) in place.

(Note: The bracket (A9) must be secured to the top of main frame as shown.)

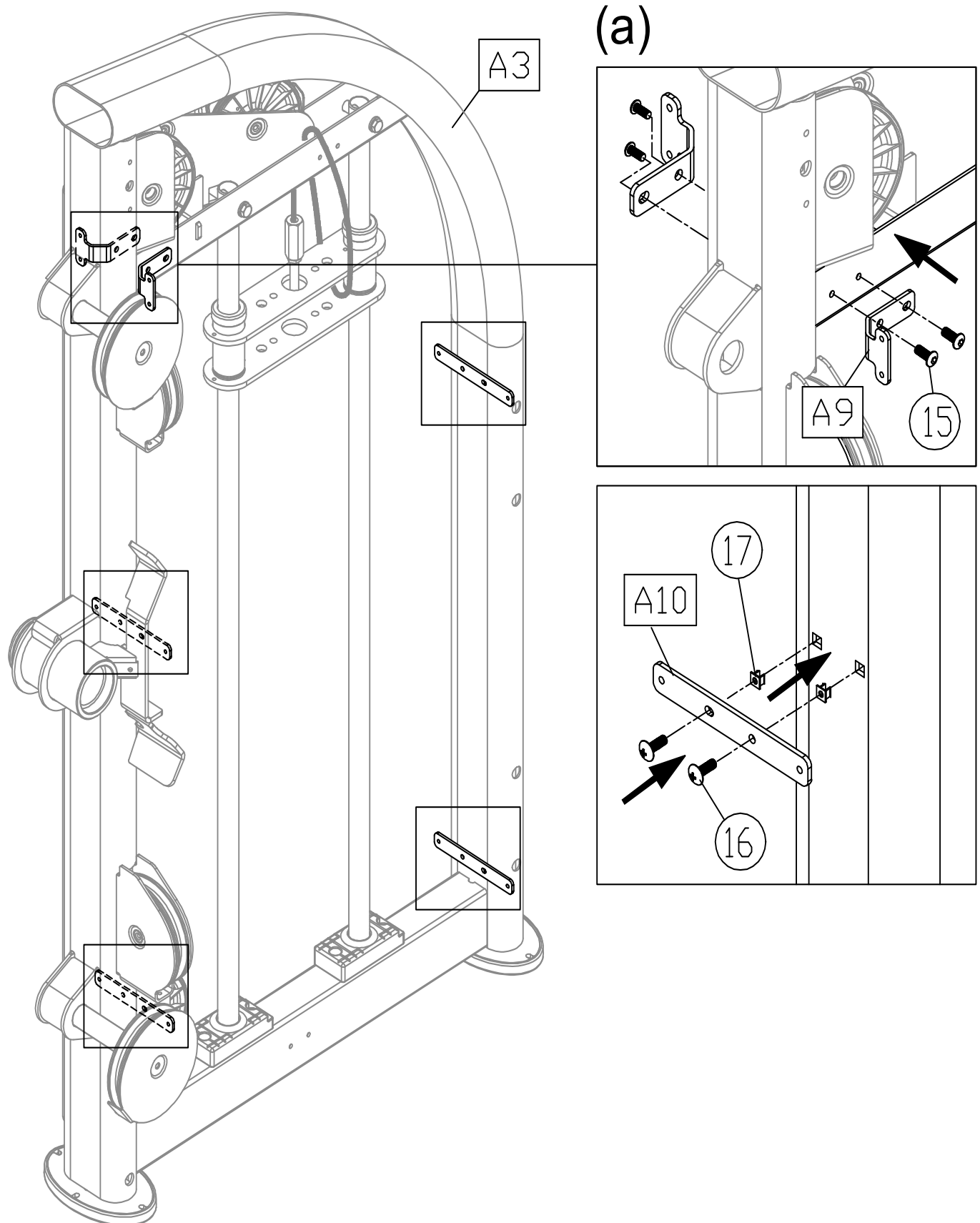

STEP 1 Cover Support Plate and Connector Installation (CONT.)

- (b) Secure the plate slots (A10) to the straight frame of the weight stack tower (A3) with the screws (18) and then cover the cap nuts (60). The plate slots (A4, A5) are secured to the left and right side of the curved frame, respectively. (Note: The plate slots have to be secured outside of the anchor brackets (A9, A10).)

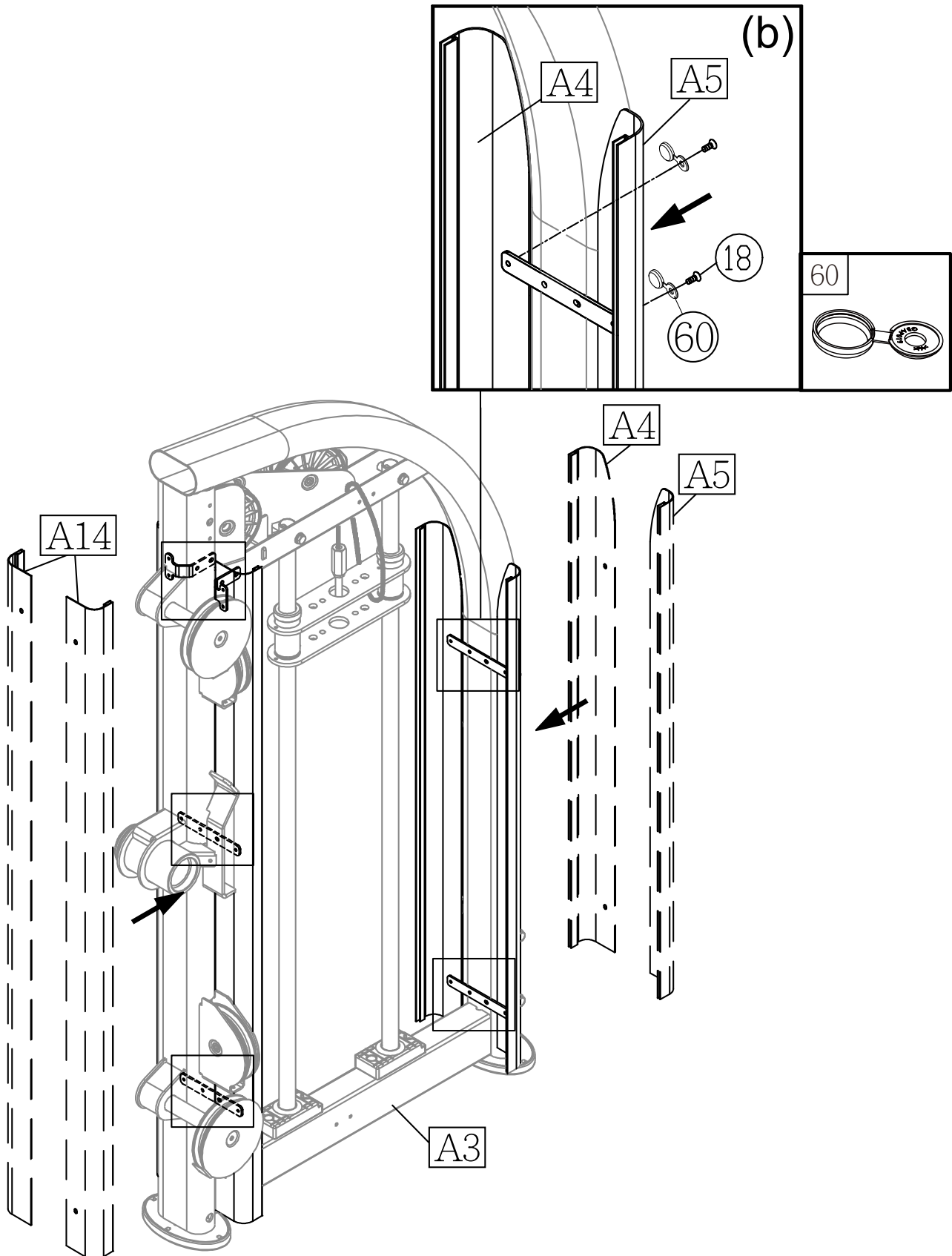

STEP 1 Cover Support Plate and Connector Installation (CONT.)

(c) Use screws (25) to secure the connecting board A (A34) to the connector C (A33) and the main frame (A3) in area A. Use screws (25) to secure the connecting board (A35) to the connector C (A33) and the seat frame (A26) in area B. And then use screws (25) to secure the connecting board (A35) to the connector A (A31), the connector B (A32), the main frame (A3) and the seat frame (A26) as shown.

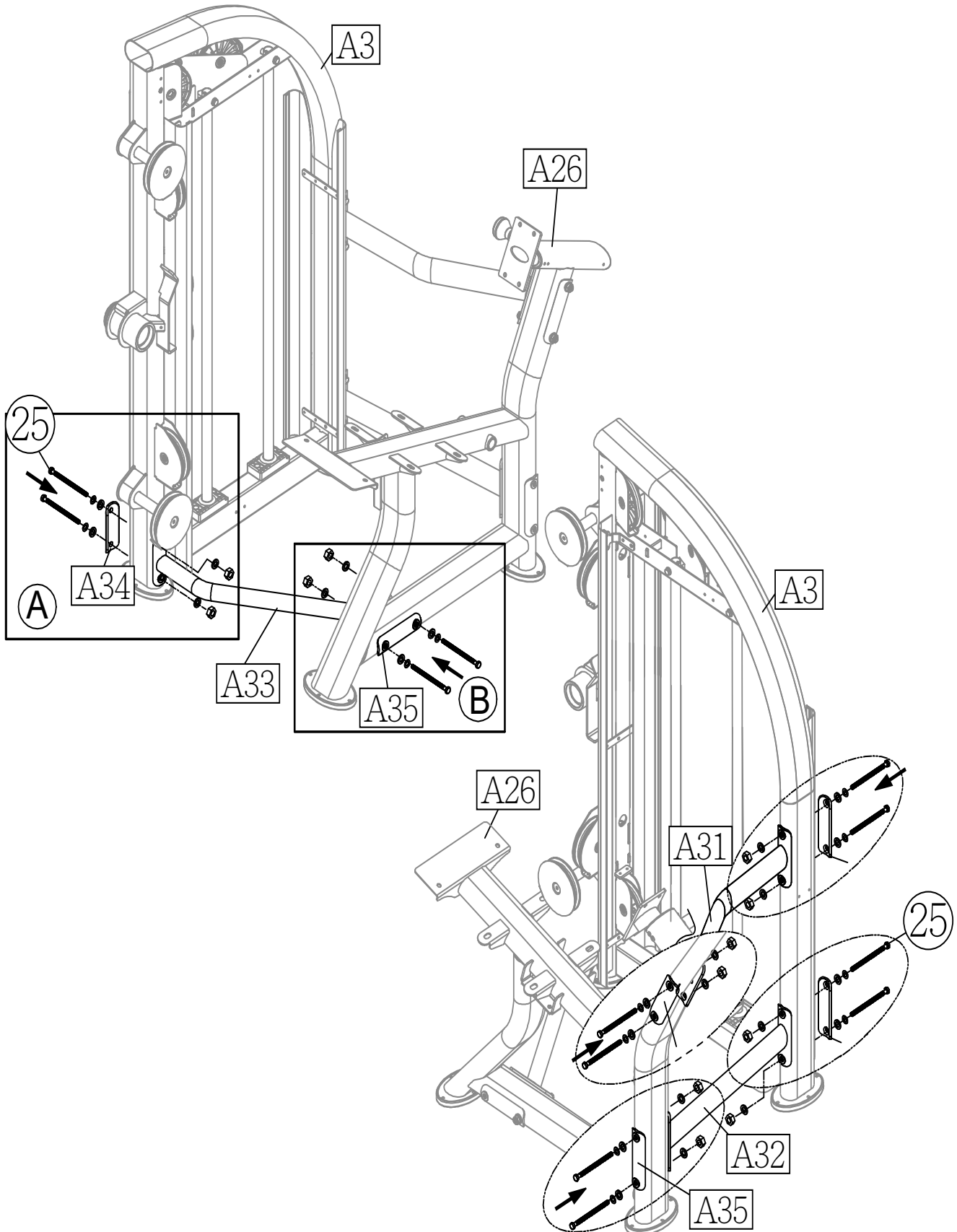

STEP 2 Weight Stack Installation

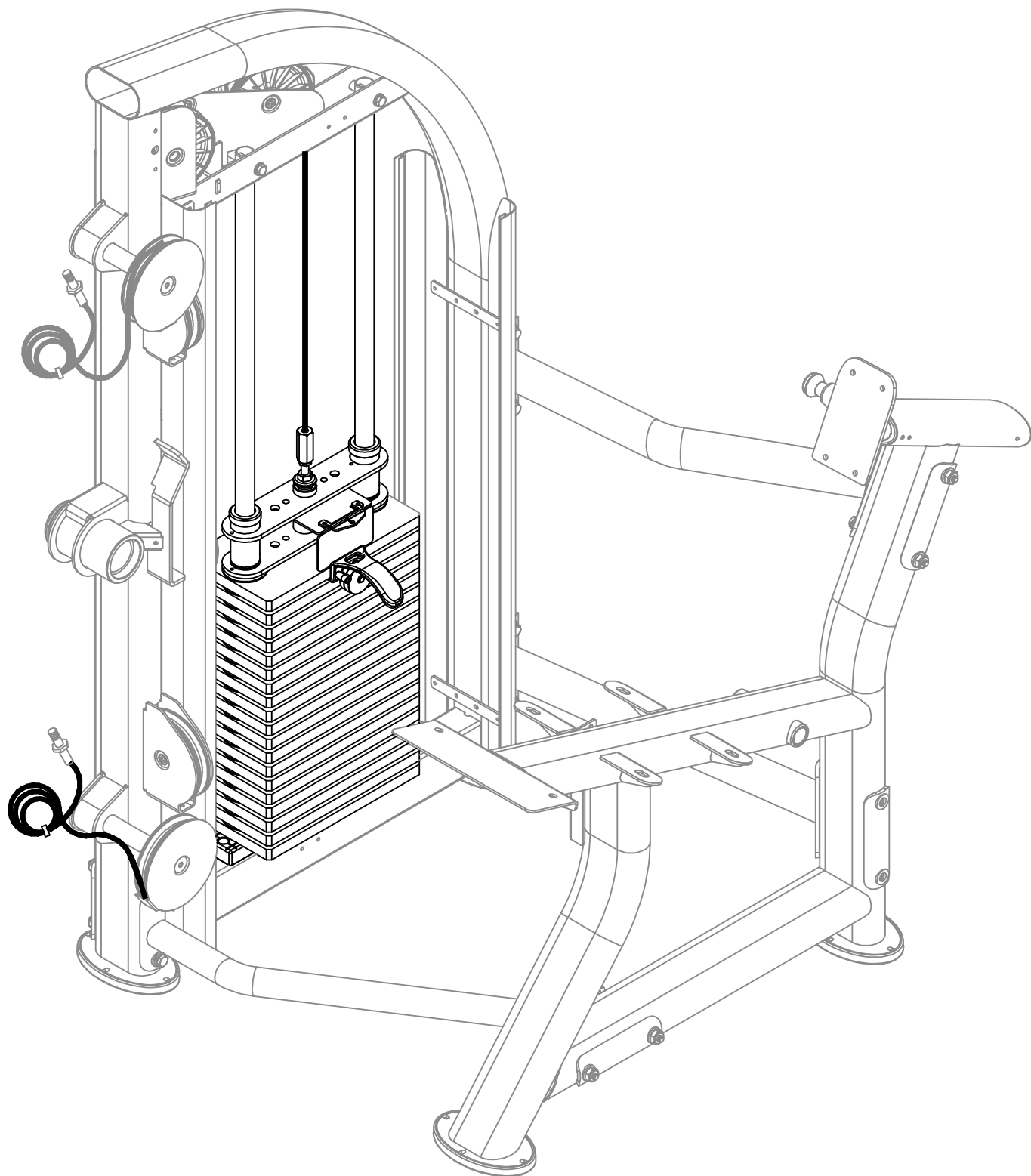

STEP 2 Weight Stack Installation (CONT.)

Follow instructions (a) through (g) to install the weight stack.

(a) Hold the upper stack carriage set (32), and then cut the zip tie. Gently lower the upper stack carriage set (32) into place as shown.

(b) Remove screws (33) (34). Set the guide rod (35) downward into place as shown.

(c) Tilt the guide rod (35) backward and then lift the upper stack carriage set (32) off the guide rods as shown. Carefully set the upper stack carriage set (32) aside.

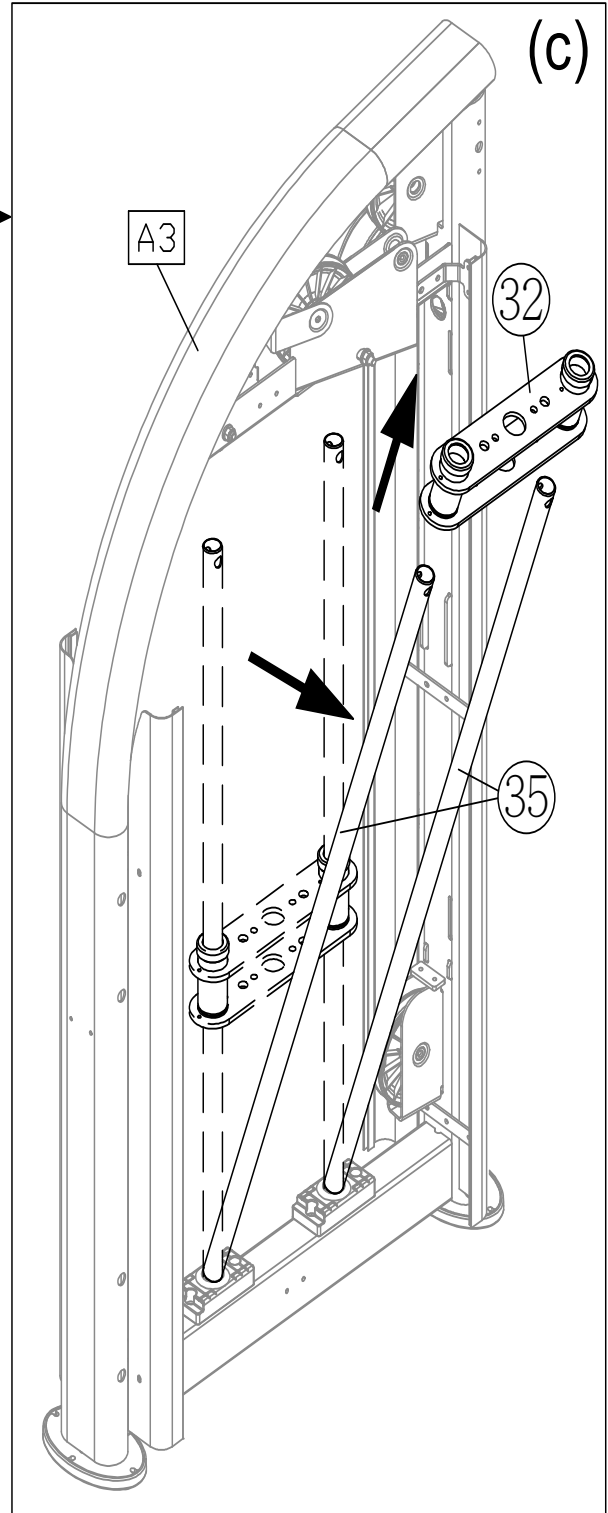
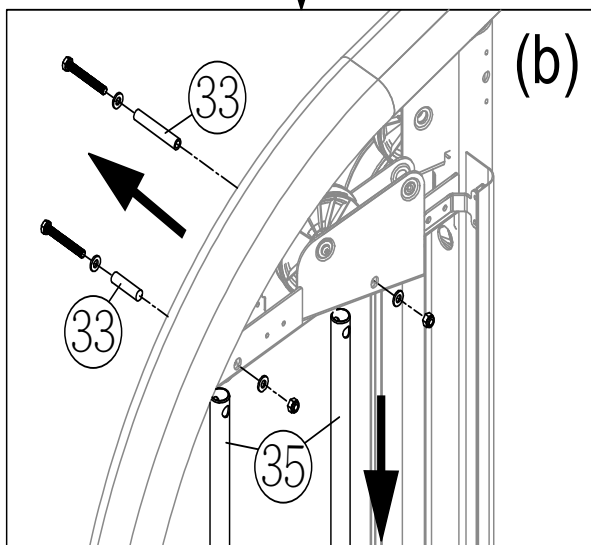
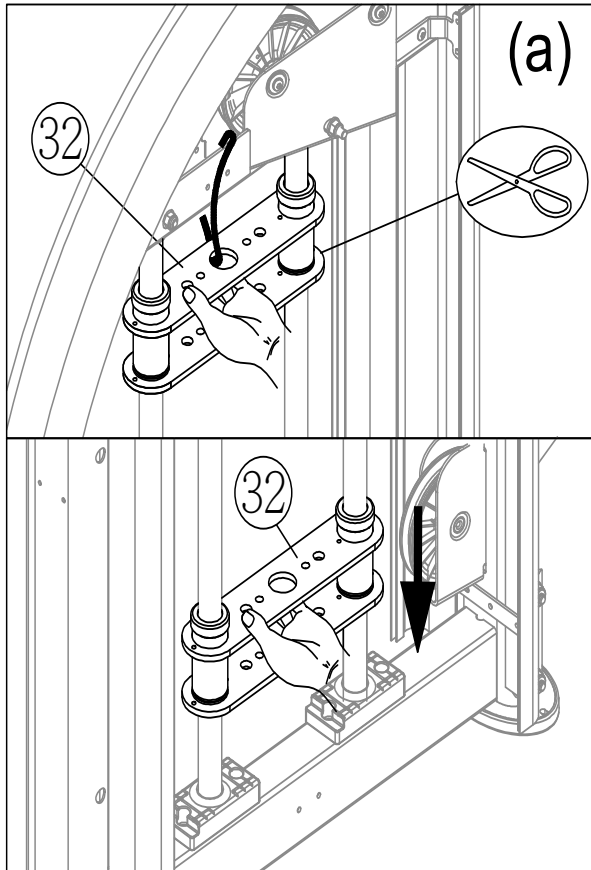

STEP 2 Weight Stack Installation (CONT.)

(d) Remove screws (36) from the stack fork (A6) and insert the weight stack rod (A7) into the central mounting position of the upper stack carriage set (32). Use screws (36) to secure the stack fork (A6) into place of the upper stack carriage set (32) as shown.

(Note: Remove the stack fork first before assembling.)

(e) Remove screws (57) from the set fork (58) to remove the bolt assy. crossover (59). Pull the cable from the stack fork (A6) to thread through the bolt assy. crossover (59) as shown. Secure the bolt assy. crossover (59) back into place of the set fork (58) with screws (57) as shown.

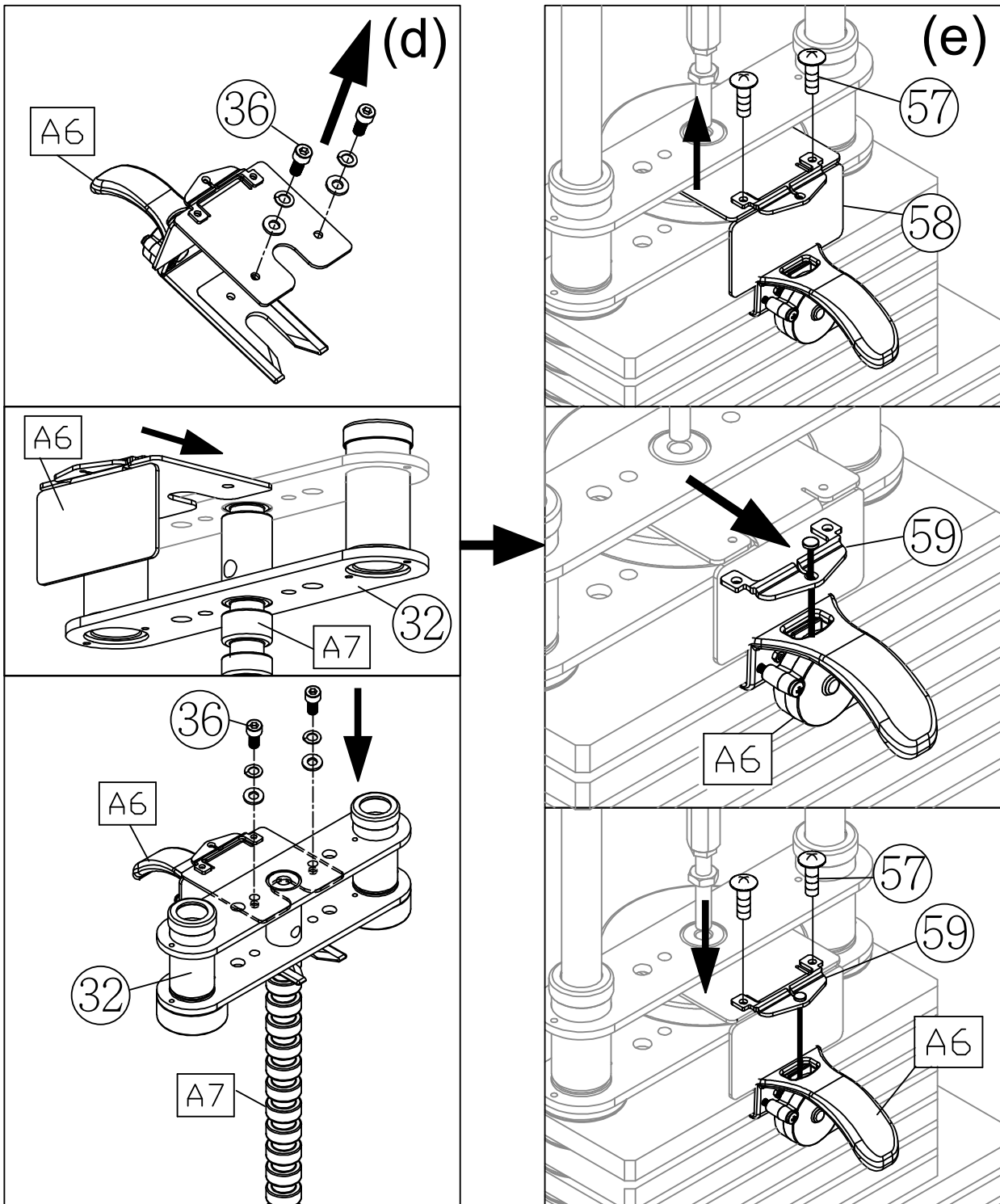

STEP 2 Weight Stack Installation (CONT.)

(f) Insert and lower the (5 kg/11lb) weight plate (A40) into place on the guide rods (35) one at a time. Once complete, slide down the upper stack carriage set (32) on top of the weight stack. (Note: The convex side of weight plate should face up and the stack fork (A6) points toward the front.)

*If there is an optional (7.5kg/16.5lb) weight plate installed, insert the optional weight plates before the (5 kg/11lb) weight plates (A40).

*Install the cap nuts on the screws.(g) Tilt the guide rods (35) back into place and then lift them up to their mounting position, and then secure the assembly with screws (33) (34).

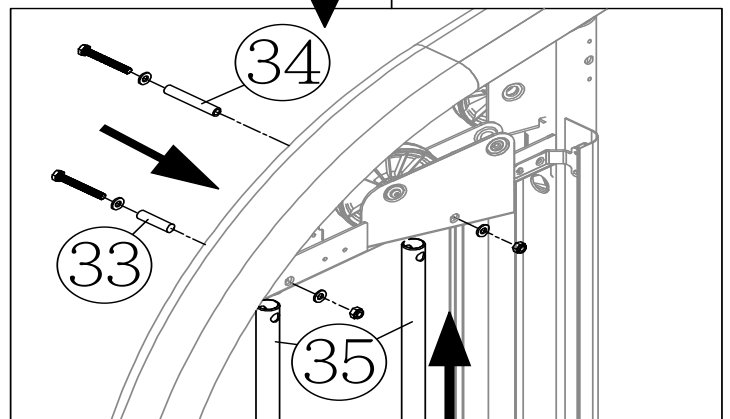
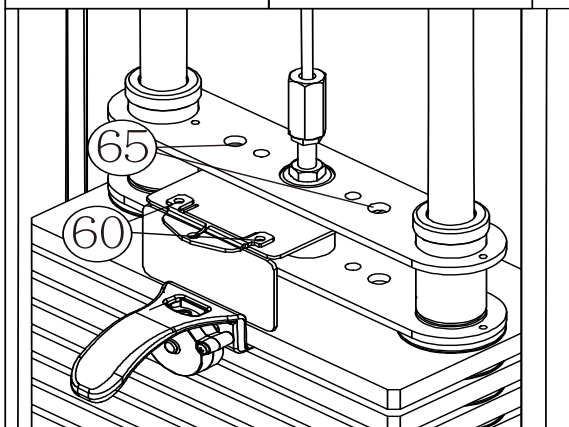
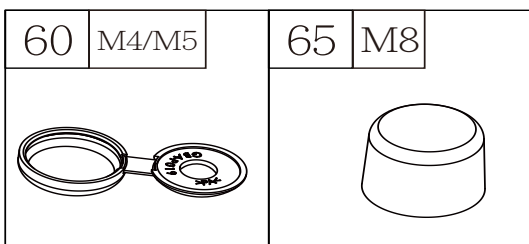
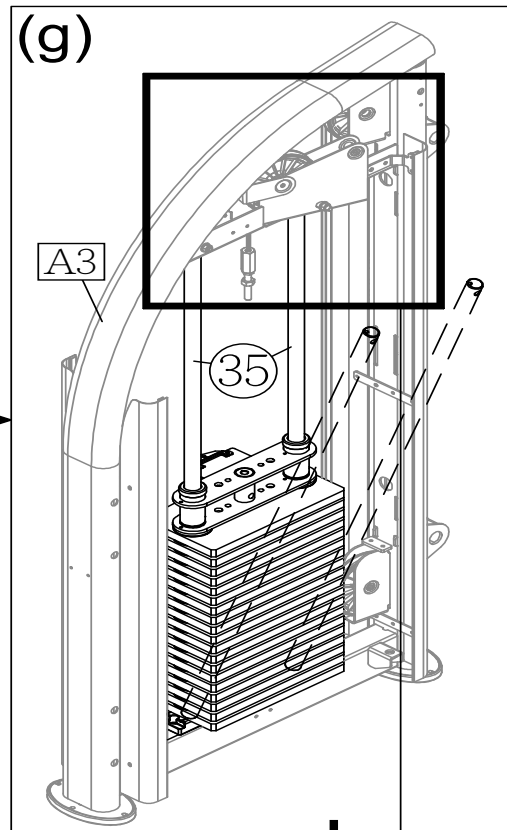
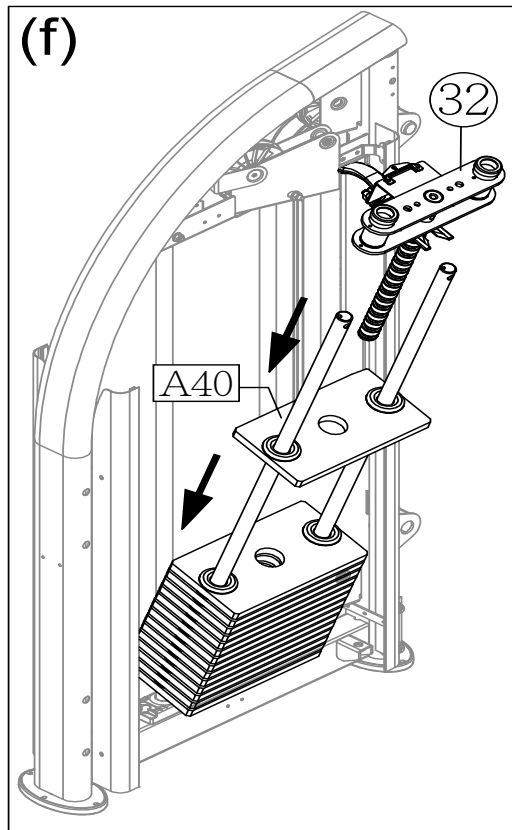

STEP 3 Apply the Weight Stack Sticker

Note: Before applying weight plate stickers, please wipe the area clean, and clean your hands before proceeding to the next step.

- (a) Align and tape the cardboard to the upper left corner of the weight plate (A40).
- (b) Peel off the top half of the weight plate sticker (A41) backing. Leave the clear outside margin in place on the sticker. Don't peel off the margin.
- (c) Press the numbered part of the weight plate sticker (A41) in place while you peel off the clear margin of the sticker.
- (d) Peel off the clear margin of the sticker.
- (e) Follow steps (b) ~ (d) to apply another weight plate sticker to the lower part of the weight stack. When the stickers are in place, peel off the cardboard. Press the sticker in place to ensure good contact on the weight plate.

*If there are additional optional weight plates, use the optional weight plate stickers.

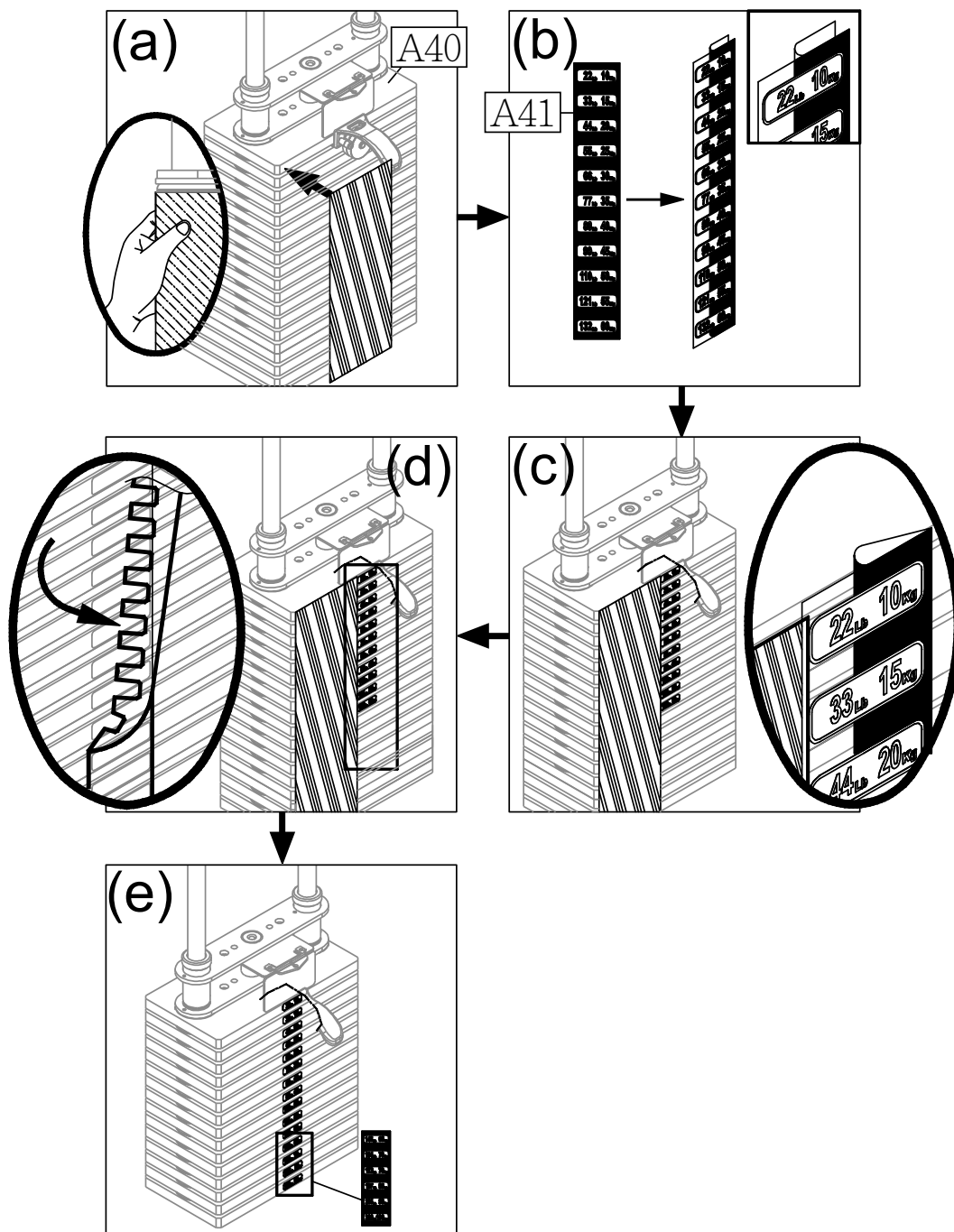

STEP 4 CAM Installation

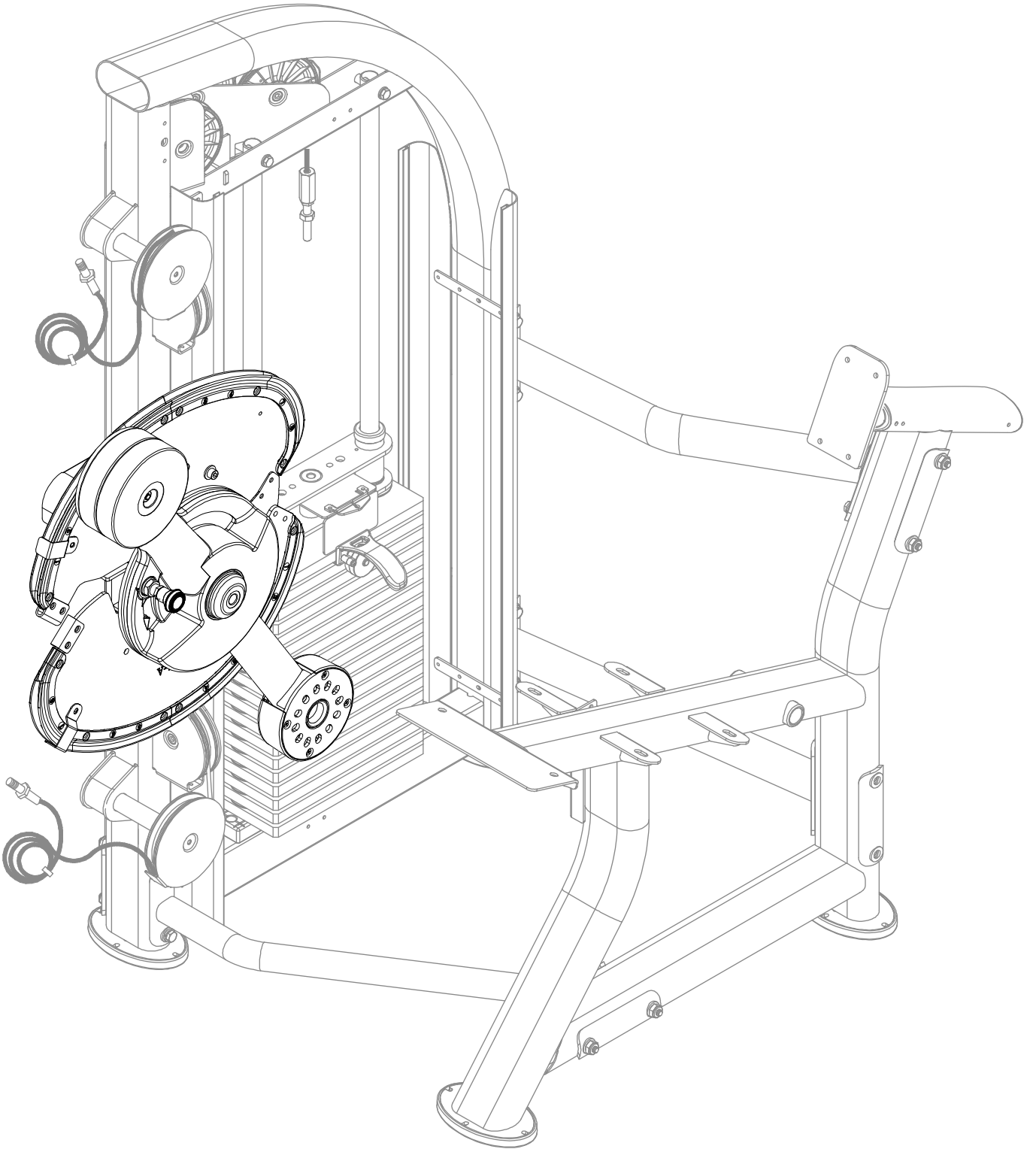

STEP 4 CAM Installation (CONT.)

Follow instructions (a) through (f) to install the CAM.

(a) Remove screws (37) and the axle cover (38) from the CAM (A20).

(b) Place the CAM (A20) horizontally into its mounting area, and then rotate the CAM so that the rotator arm is pointing upward as shown.

(Note: The cable isn't connected to the CAM yet, to avoid any injuries, do not allow people to be near this area when rotating.)

(c) Secure the axle cover (38) in place with screws (37), and then apply the round sticker (19) as shown. Finally, cut the zip tie on the two sides of the CAM as shown.

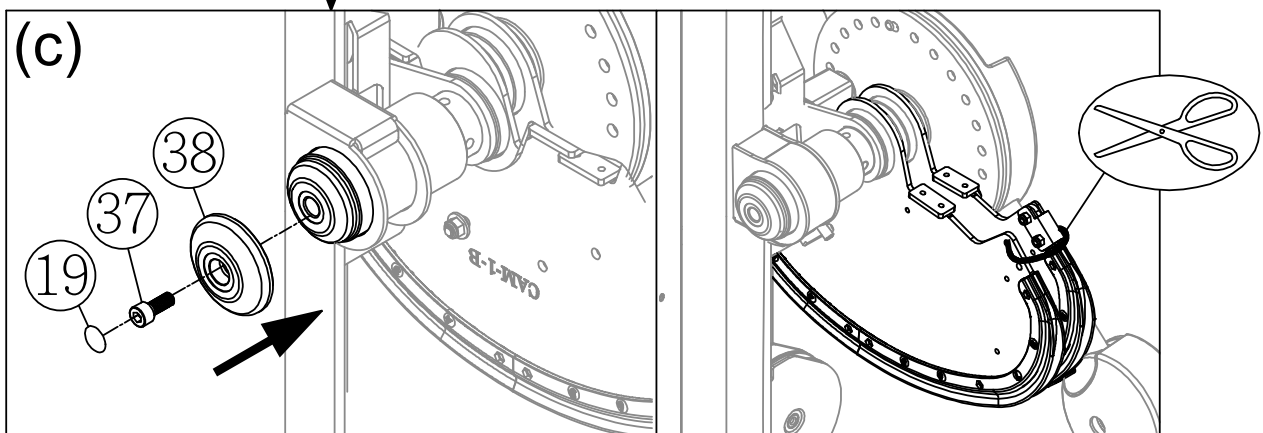
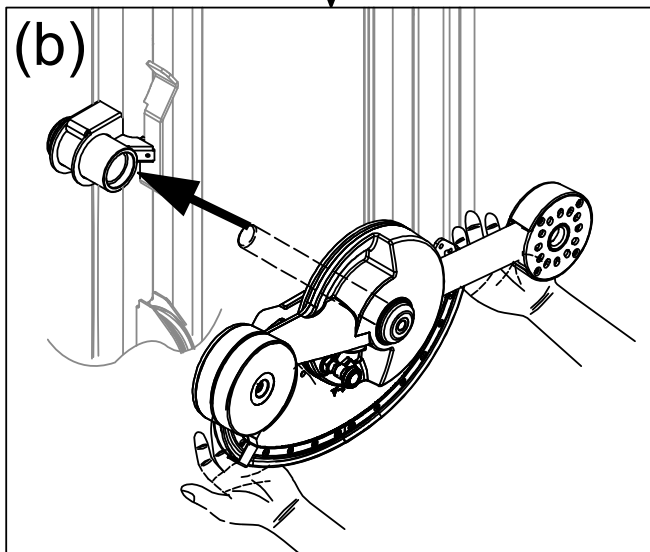
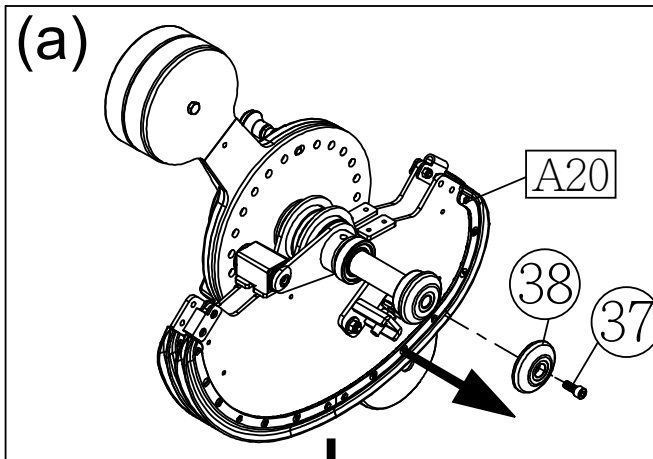

STEP 4 CAM Installation (CONT.)

(d) Use screws (47) to secure the stopper A (A22) to the CAM (A20).

(Note: The correct stopper position is indicated by the "O" as shown.

The incorrect position is indicated by the "X" as shown.)(Note: Make sure screws are secured in the correct position as shown.)

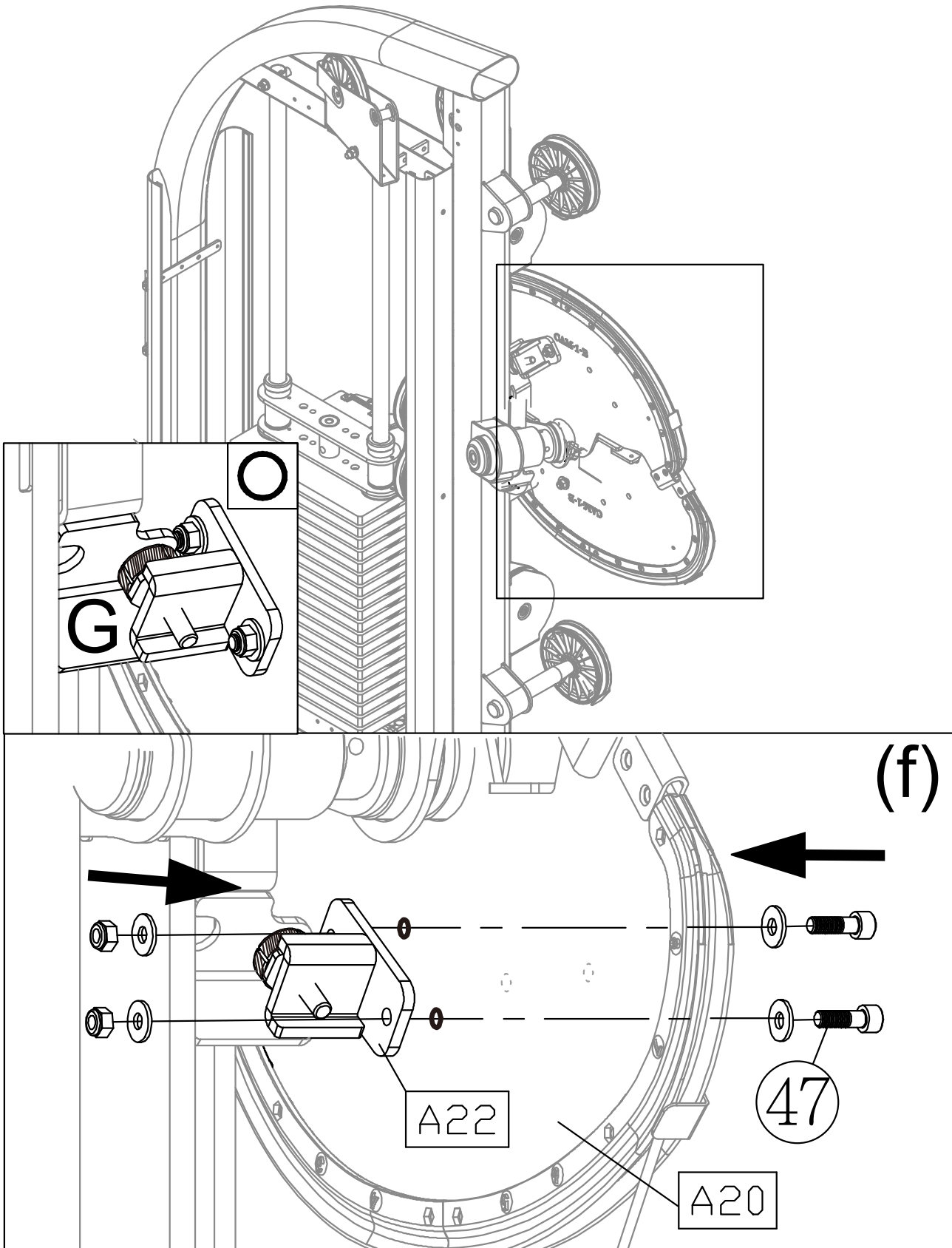

STEP 5 Cable Installation

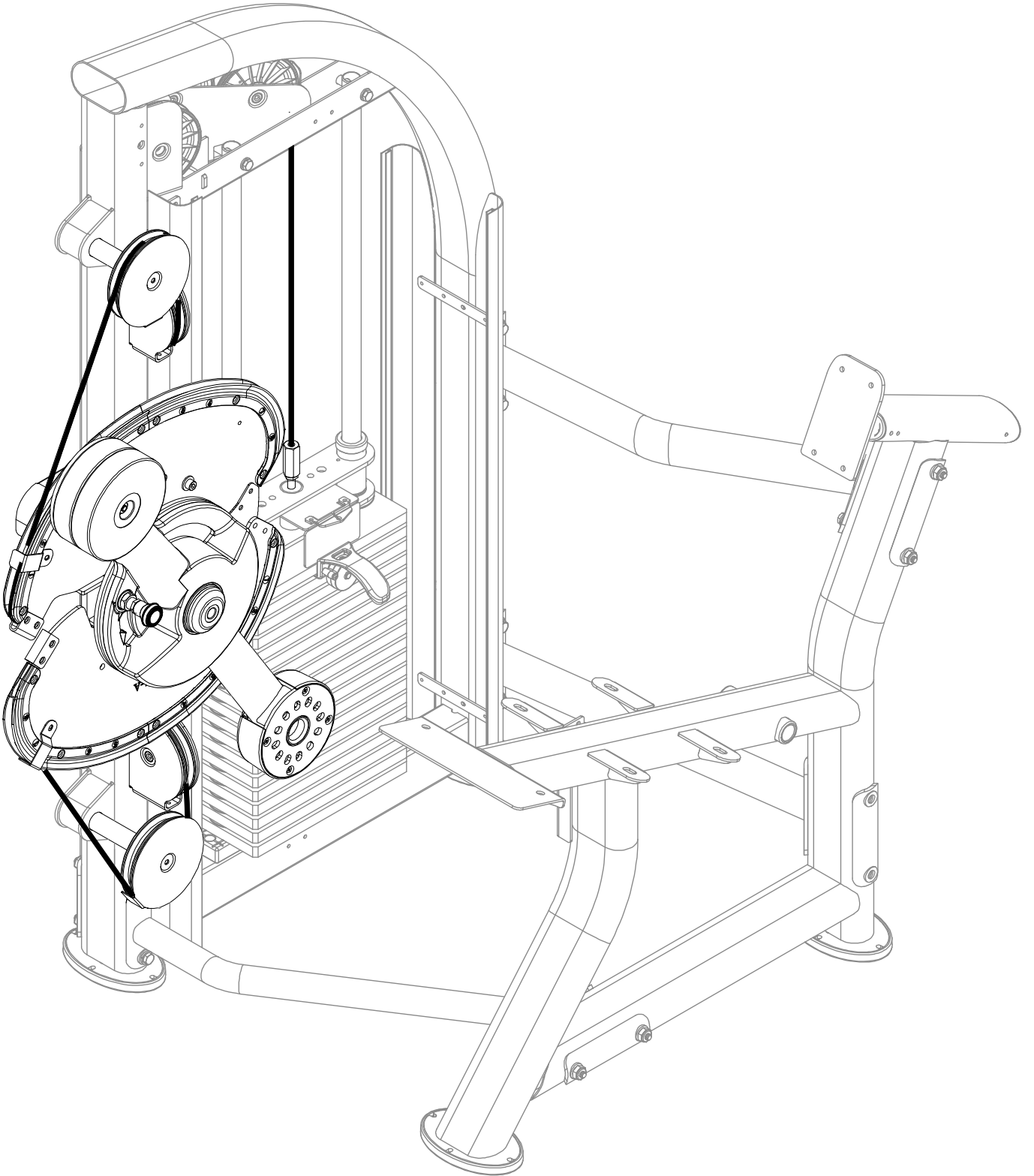

STEP 5 Cable Installation (CONT.)

Follow instructions (a) through (c) to install the cable nut and the stack rod.

(a) Insert the cable nut as indicated by the arrows onto the weight stack rod (A7) at least 20mm deep as shown.

(b) Take out the stack fork (A6) and lift the upper stack carriage set (32) up.

(c) Insert the stack fork (A6) into the stack rod (A7) to loosen the cable.

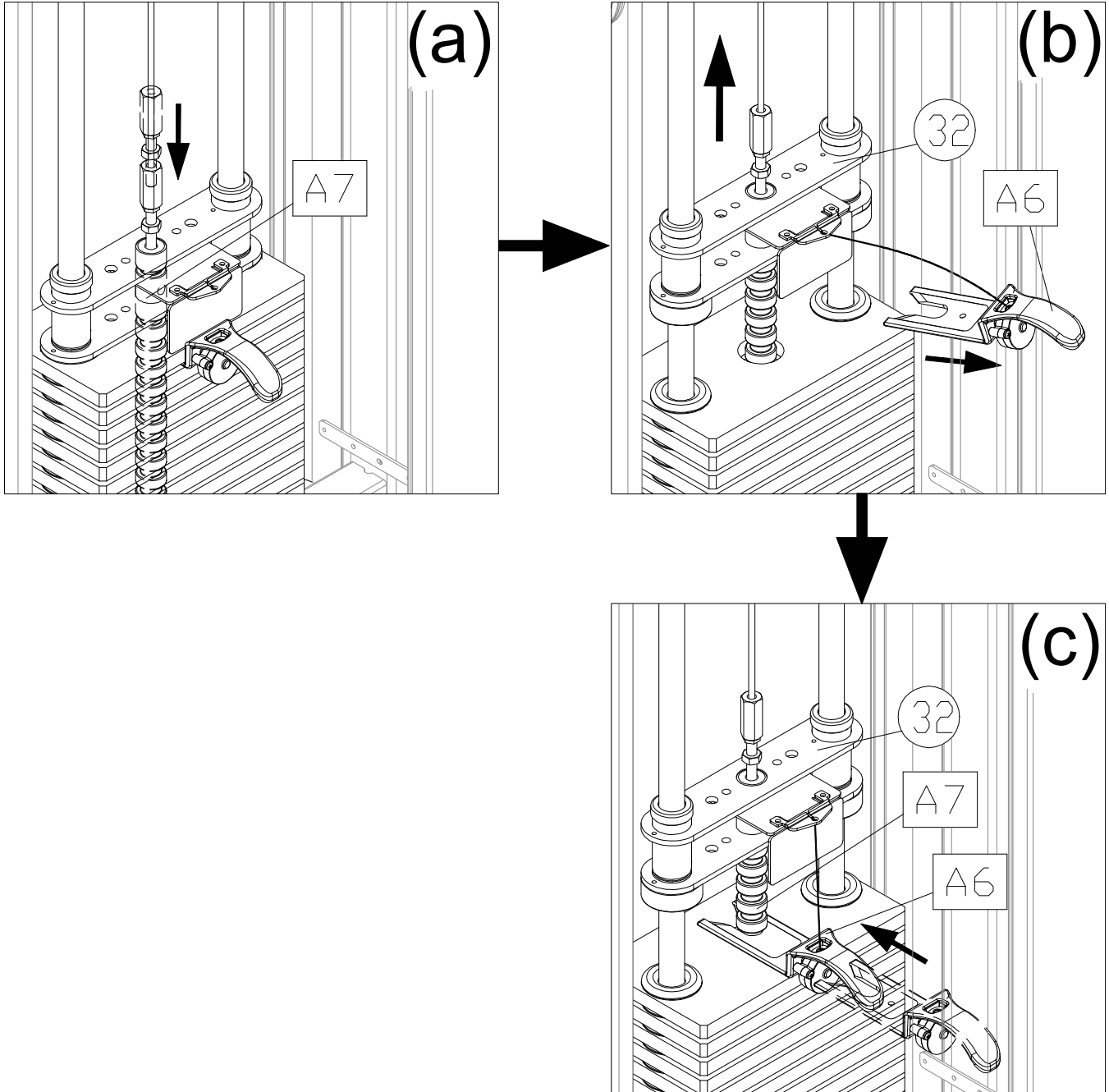

STEP 5 Cable Installation (CONT.)

Follow instructions (a) through (d) to install the upper cable.

(a) Remove screws (40) from the main frame (A3) and then install the pulley (A37) and thread the cable goes through the pulley (A37) as indicated by the arrows. Secure the pulley cover (41) in place with screws (40).

(Note: When securing the pulley cover, make sure the cover does not interfere with cable motion.)

(b) Remove screws (43) (45), the CAM stop plate (42) and the cable set block (44) from the main frame.

(c) Cut off the zip tie to uncurl the cable and pull the cable as indicated by the arrows as shown.

(d) Thread the cable through the cable set block (44) as indicated by the arrows and then secure the cable set block (44) and the CAM stop plate (42) back into place with screws (43) (45).

(Note: When securing the cable set block (44), make sure the cable nut must rest outside as shown and the CAM stop plate (42) does not interfere with cable motion when securing it back into place.)

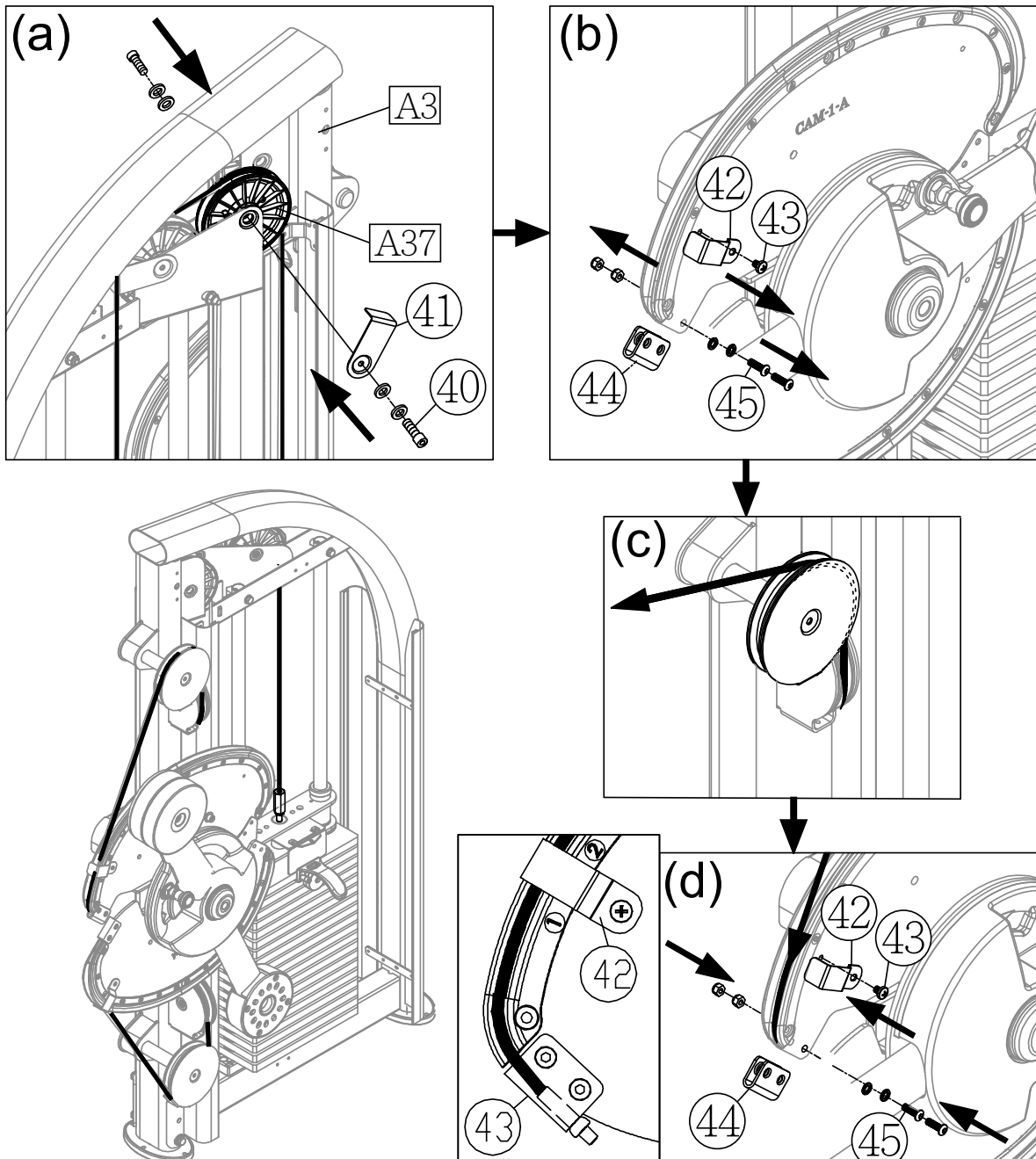

STEP 5 Cable Installation (CONT.)

Follow instructions (a) through (c) to install the lower cable.

- (a) Remove screws (43) (45), the CAM stop plate (42) and the cable set block (44) from the main frame.
- (b) Cut off the zip tie to uncurl the cable and pull the cable as indicated by the arrows as shown.
- (c) Thread the cable through the cable set block (44) as indicated by the arrows and then secure the cable set block (44) and the CAM stop plate (42) back into place with screws (43) (45).
(Note: When securing the cable set block (44), make sure the cable nut must rest outside as shown and the CAM stop plate (42) does not interfere with cable motion when securing it back into place.)

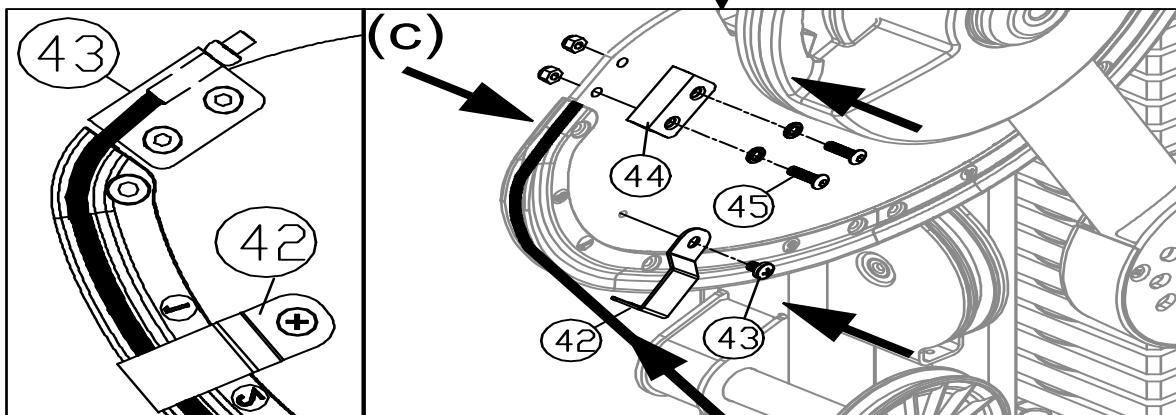
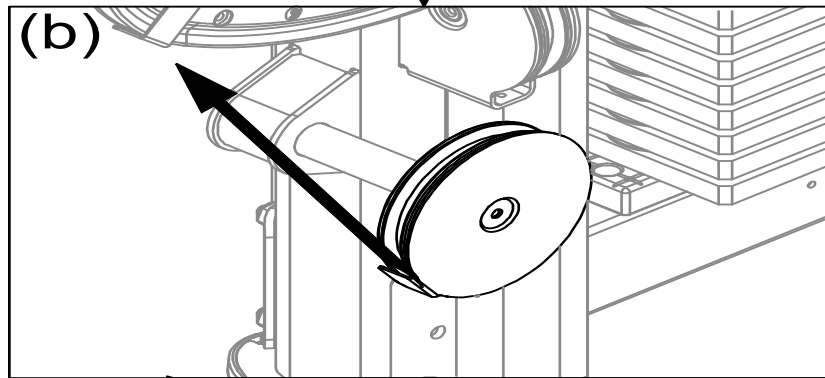
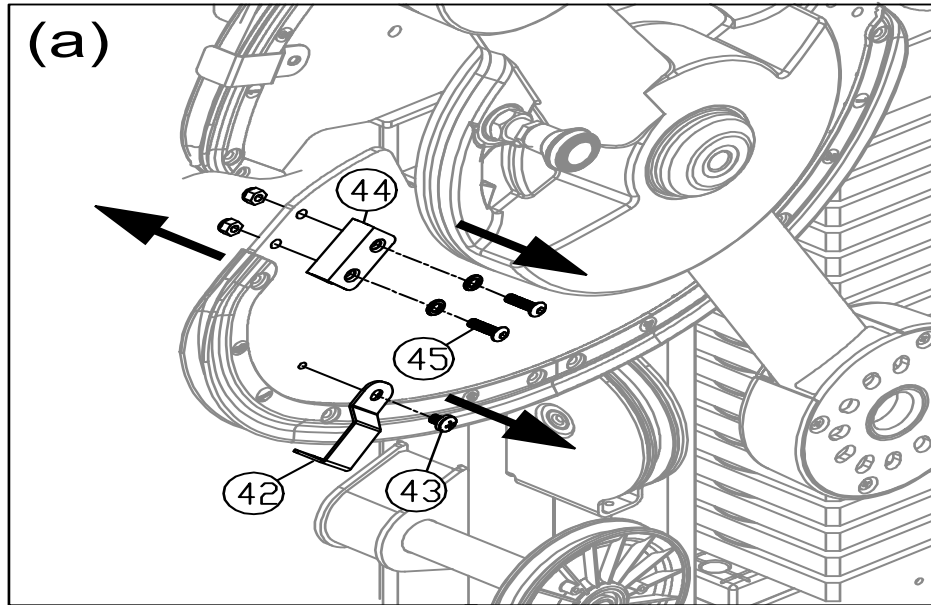

STEP 6 Floating Pulley Installation

- (a) Remove screws (46) from the floating pulley (A30) and then thread the cable goes through the floating pulley (A30) as indicated by the arrows as shown.
(Note: Keep another pulley on the floating pulley (A30) as shown.)
- (b) Thread the cable through the removed pulley and then place it back into place of the floating pulley (A30) as shown.
- (c) Secure the pulley back into the floating pulley (A30) with screws (46).
- (d) After completing the cable installation, make sure that the cable is running in the groove of the pulley and rotate the CAM to check for cable interference and its tightness. If the cable is too loose or too tight, follow the cable adjustment instruction to adjust it.

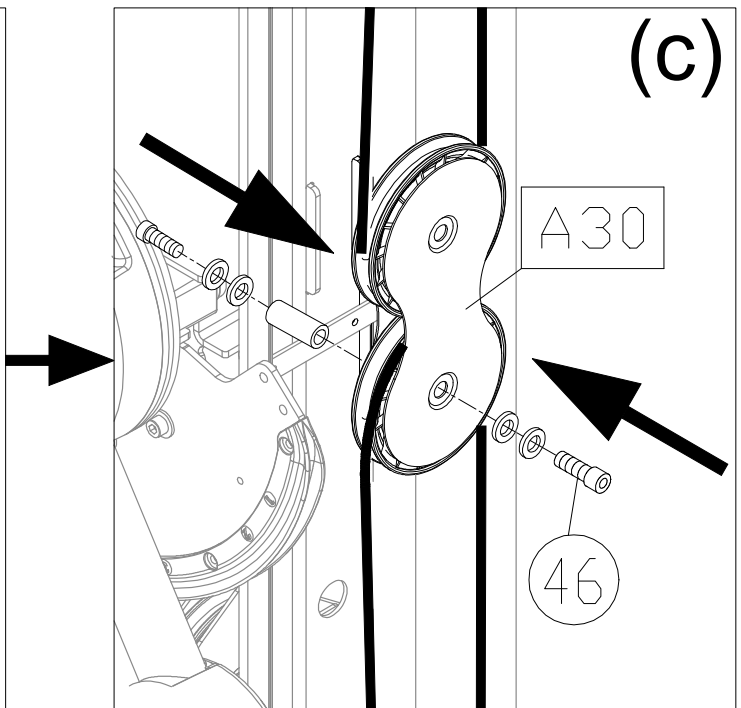
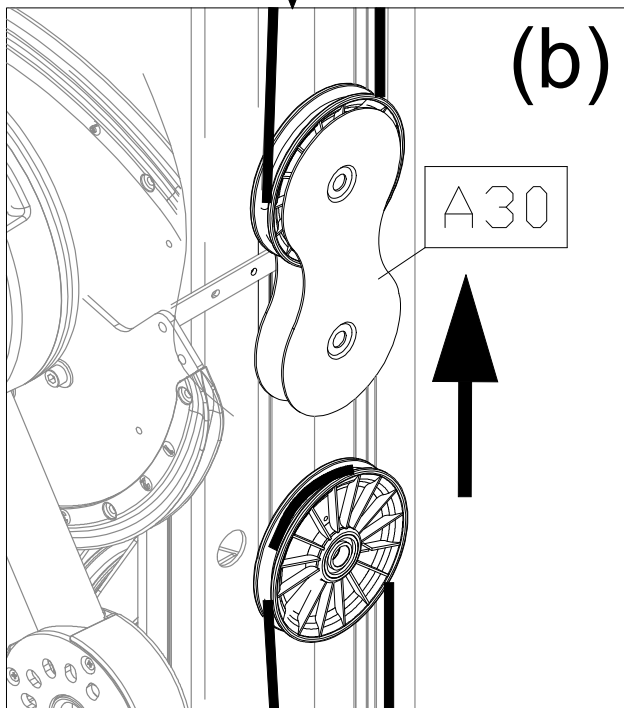
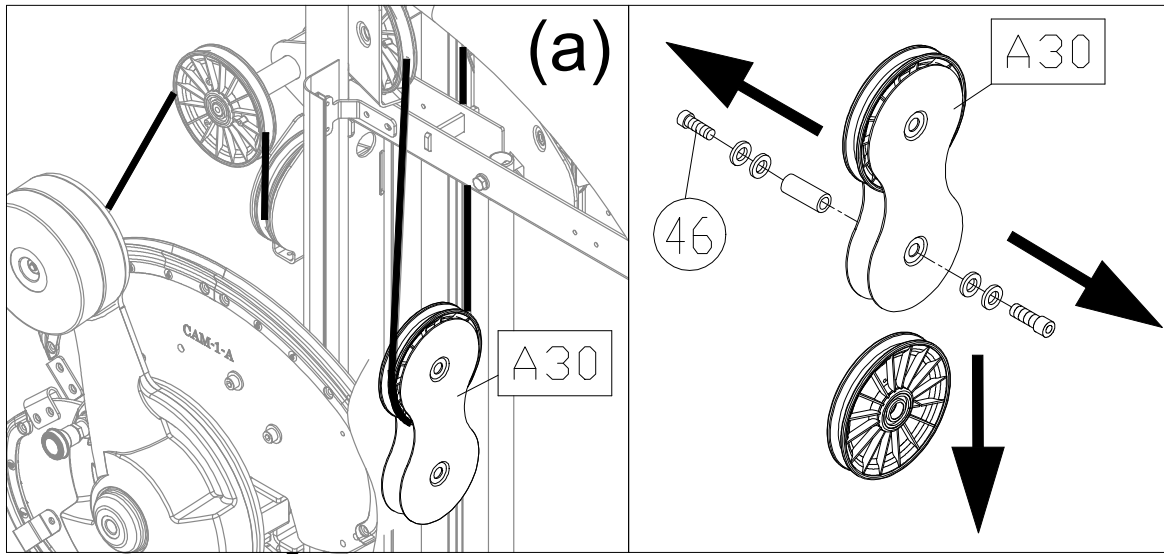

STEP 7 Finger Guard Installation

- (a) Remove screws (48) (60) from the CAM (A20).
- (b) Secure the finger guard (A21) with screws (48).
- (c) Secure the finger guard (A38) with screws (60).

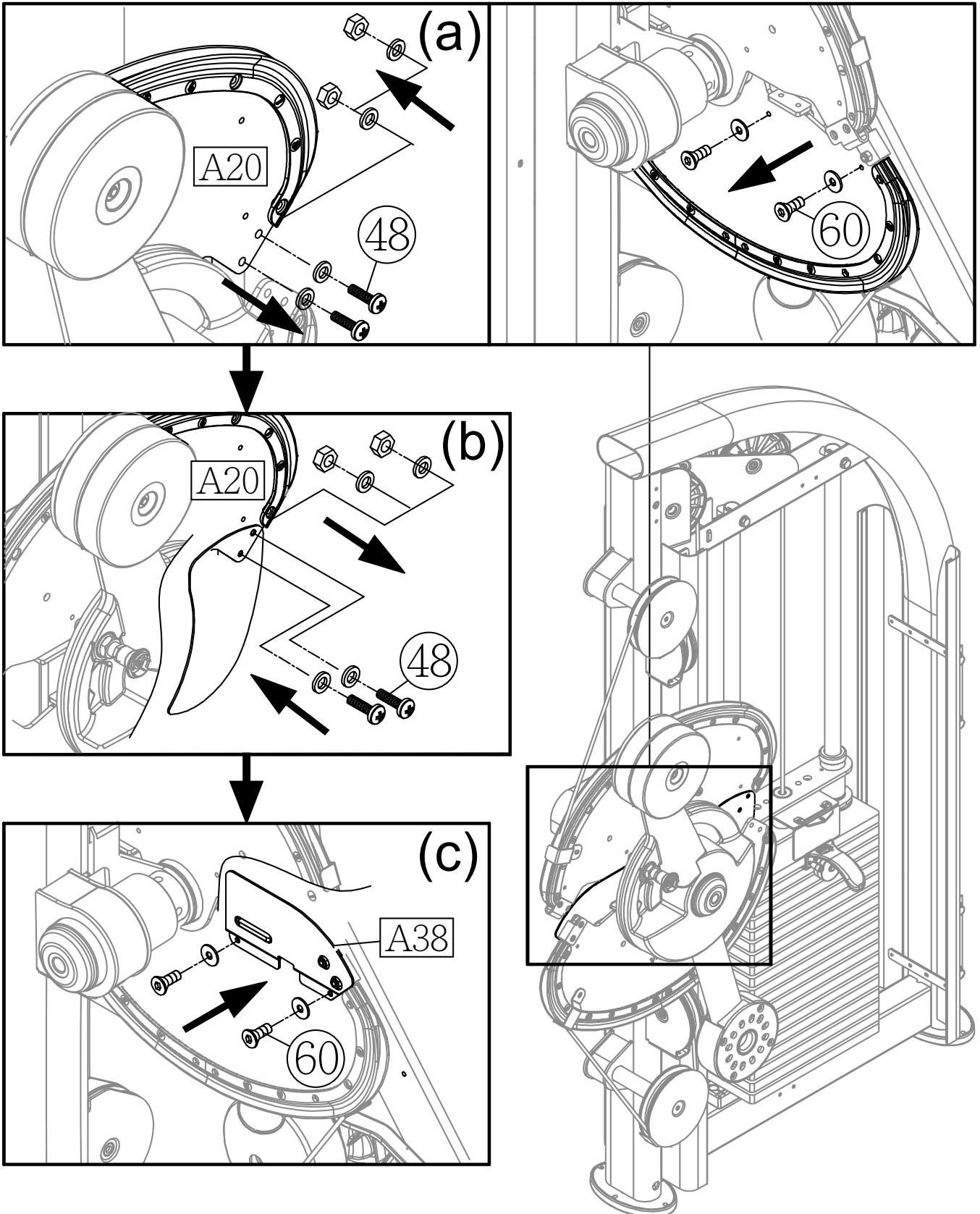

STEP 8 Cylindrical Cushion Arm Installation

- (a) First, remove screws (52) from the cylindrical cushion arm (A29).
- (b) Insert the cylindrical cushion arm (A29) onto the CAM (A20). Secure it in place with screws (52) and then insert the soft cap (20) into the CAM (A20) as shown.

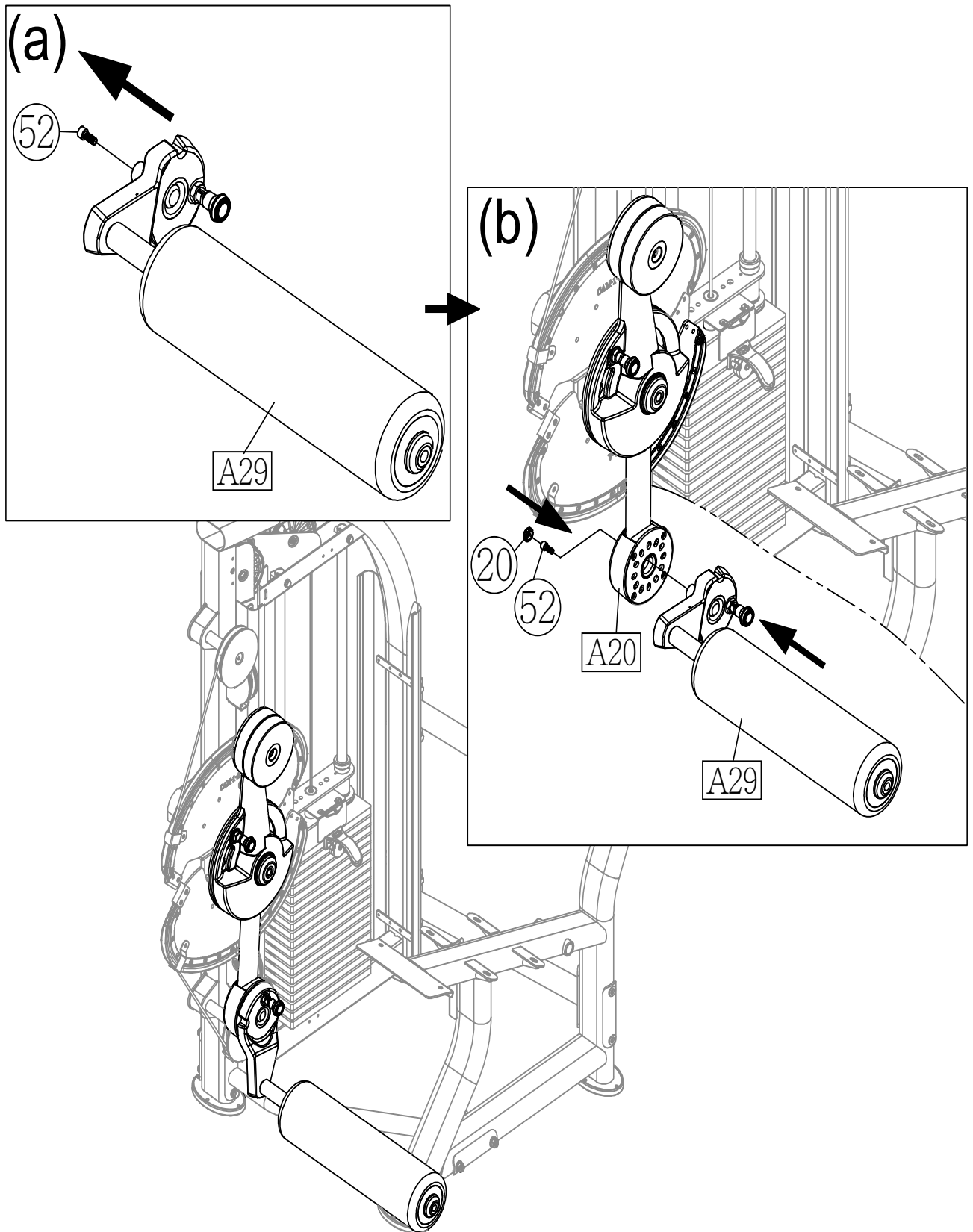

STEP 9 Upper Cable Adjustment

Insert the stack fork (A6) into the gap under the lowest weight plate and then adjust the nut at area C until the upper stack carriage moves slightly.

The gap between the (X) and (Y) nut must be within 40mm (1.6") and the (X) nut must be secured to a depth of 20mm. If the gap exceeds the 40mm limit, the cable needs to be adjusted to the proper length to avoid it's come off.

To adjust the cable, first insert an open end wrench into (Z) hole. Loosen (Y) nut and then adjust (X) nut. If the cable is too long, adjust (X) nut downward. If too short, adjust (X) nut upward. After adjusting (X) nut, tighten (Y) nut against the weight stack to secure this position.

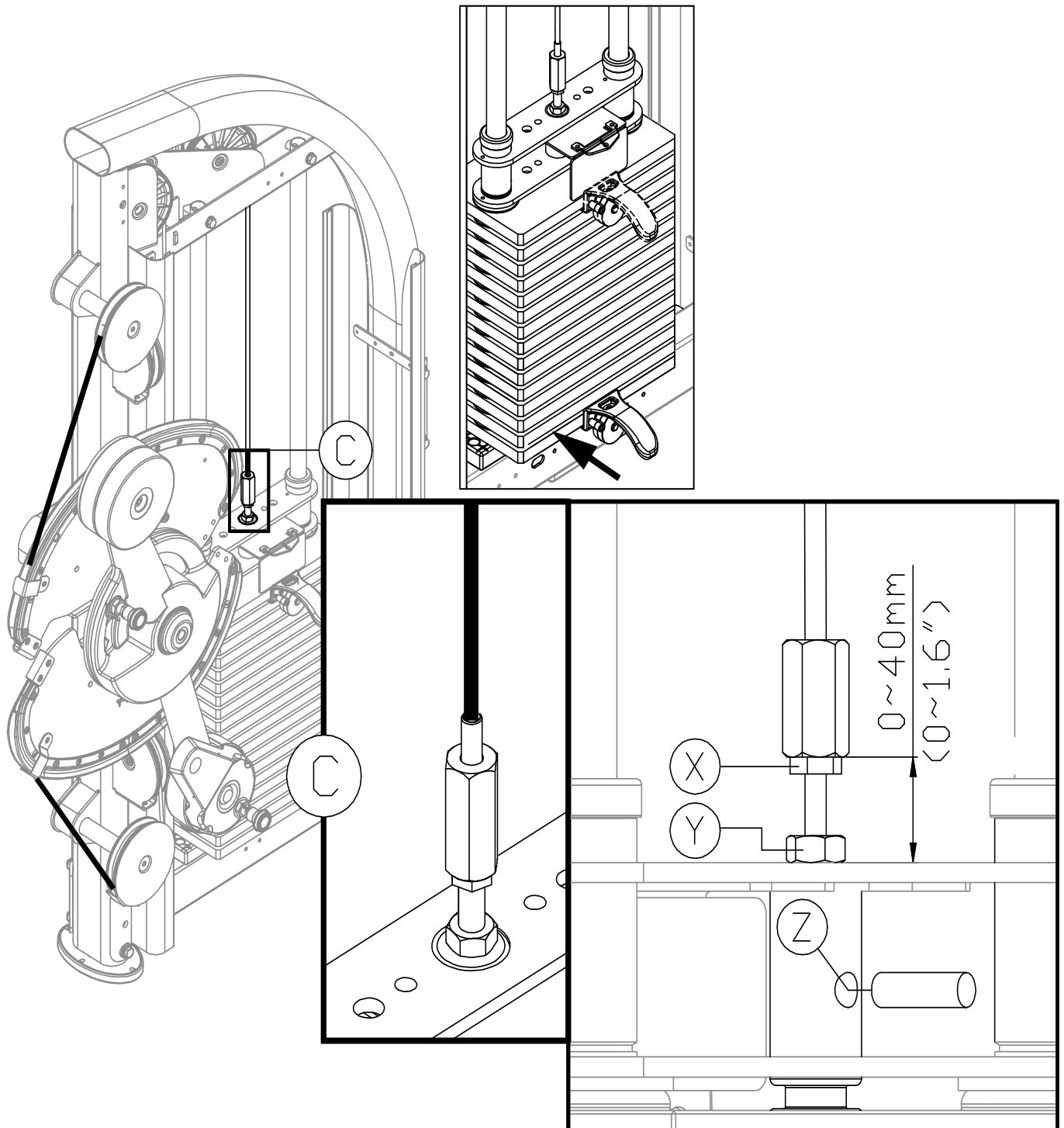

STEP 10 Lower Cable Adjustment

Insert the stack fork (A6) into the gap under the lowest weight plate and then adjust the nut at area D until the upper stack carriage moves slightly.

To adjust the cable, first insert an open end wrench into (Z) hole. Loosen (Y) nut and then adjust (X) nut. If the cable is too long, adjust (X) nut downward. If too short, adjust (X) nut upward. After adjusting (X) nut, tighten (Y) nut against the weight stack to secure this position.

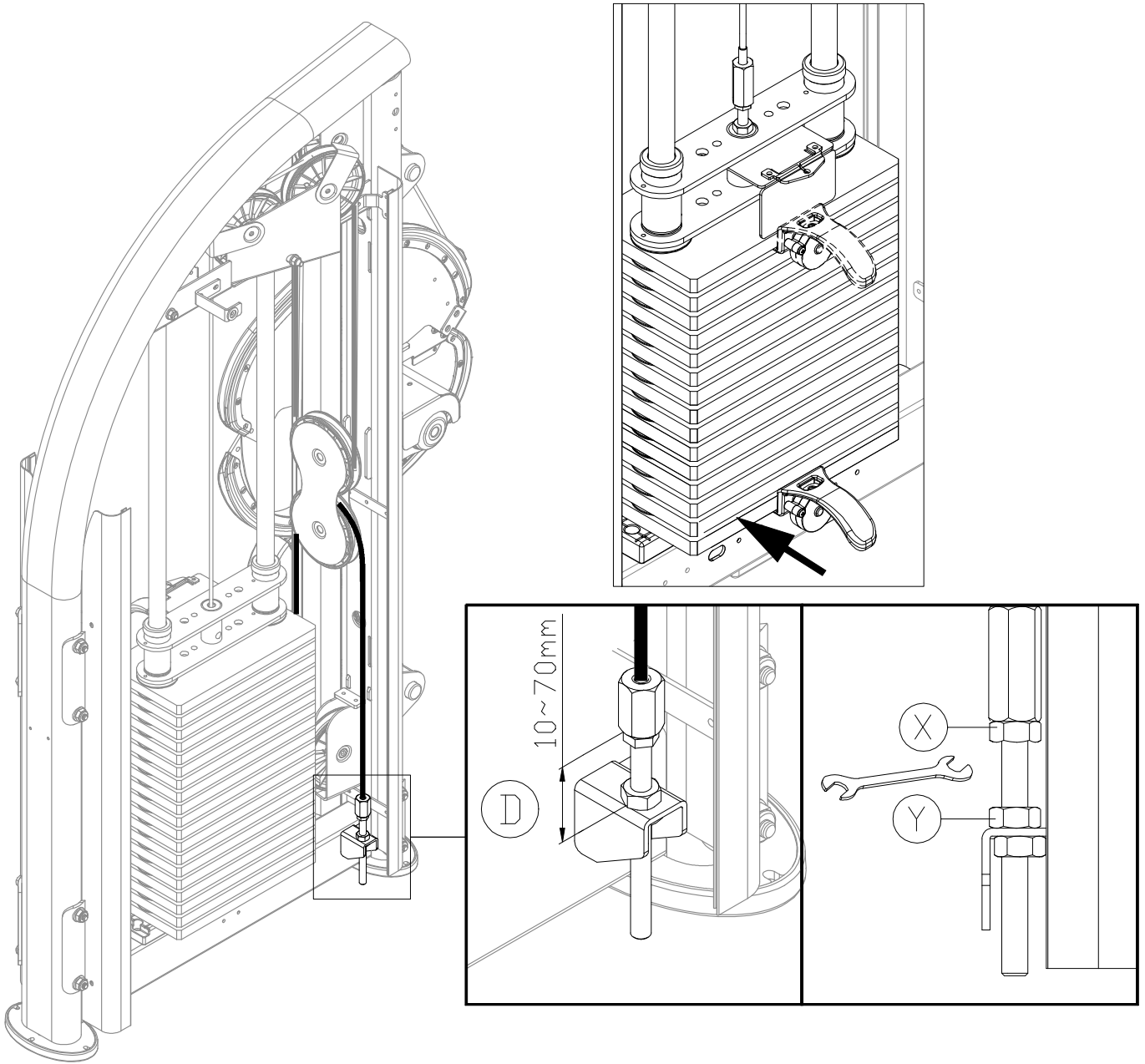

STEP 11 Upper Cushion Arm Installation

- (a) Remove screws (49) from the seat frame (A26).
- (b) Insert the upper cushion arm (A24) onto the axle of the seat frame (A26).
(Note: The whole arm must be within the set mount stopper range (B) as shown.)
- (c) Remove screws (51) and the axle cover (50) from the upper cushion arm (A24).
- (d) Put the cylindrical cushion (A23) in place on the upper cushion arm, and then secure it with the axle cover (50) and screws (51). Finally, put the round sticker (19) in place as shown.

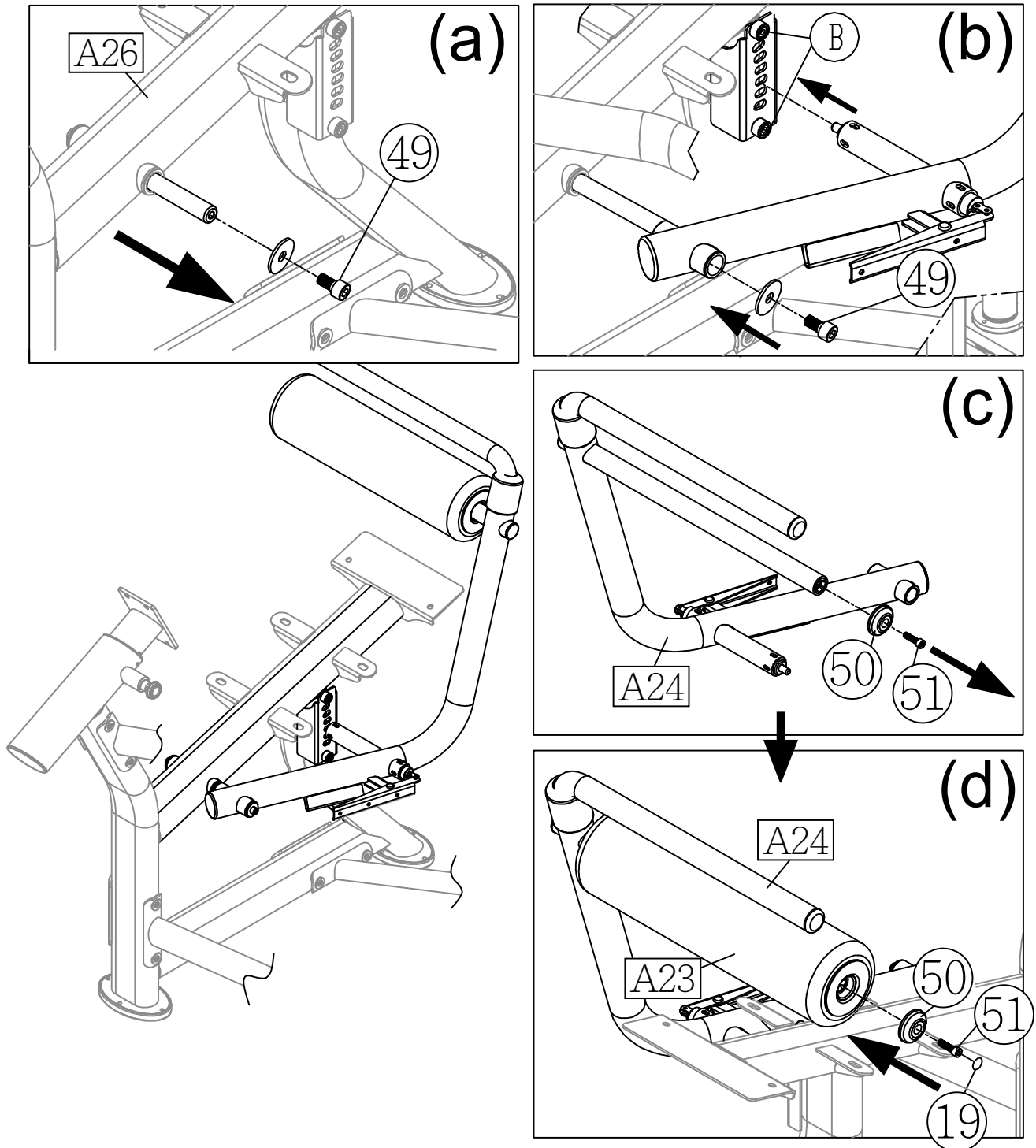

STEP 12 Seat Bottom and Seat Back Installation

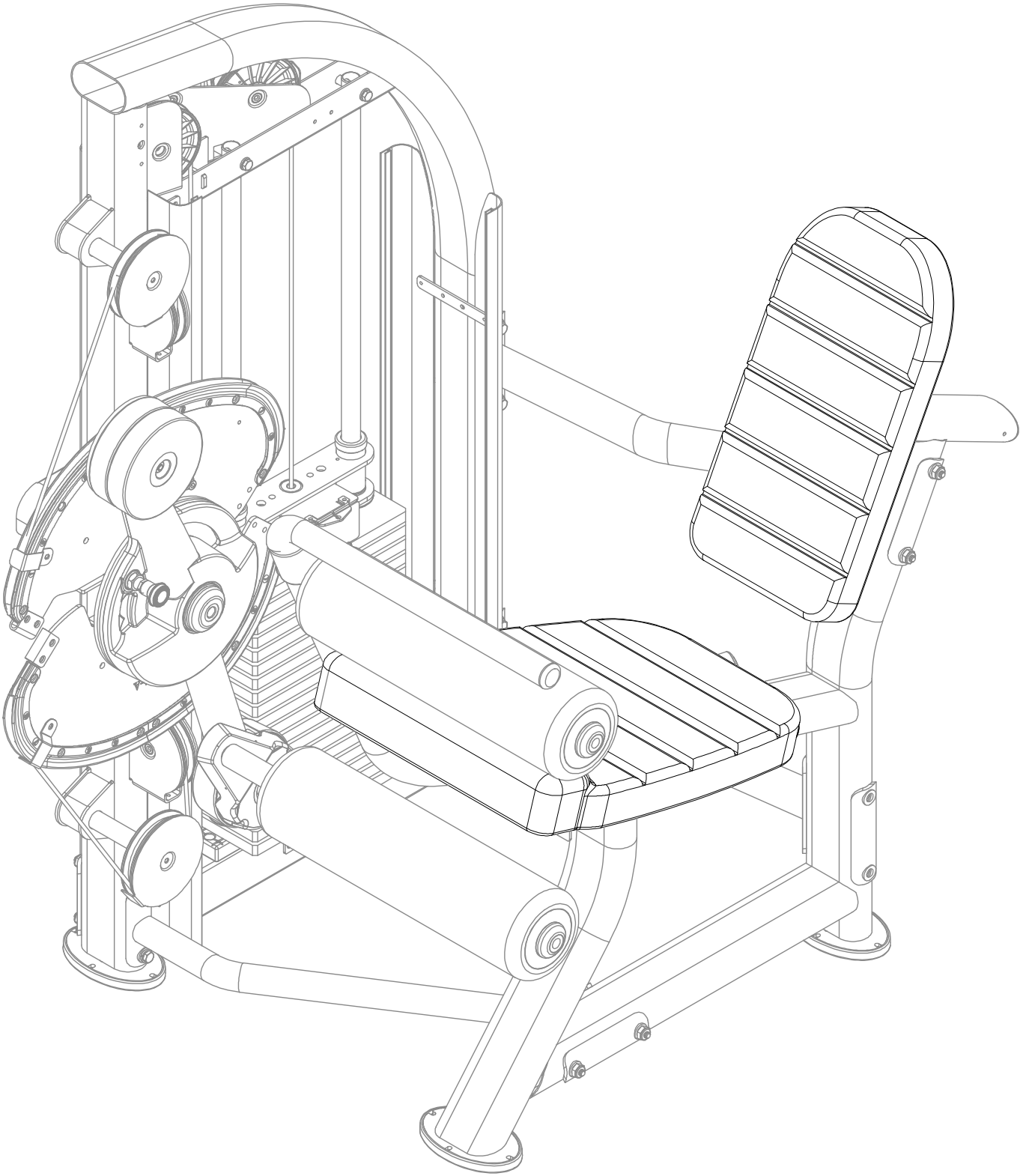

STEP 12 Seat Bottom and Seat Back Installation (CONT.)

- (a) First, remove screws (53) from the seat bottom (A28) and then remove screws (53) and the seat back plate (54) from the seat back (A25). Finally, remove screws (55) from the seat back mount as shown.
- (b) Use screws (53) to secure the seat bottom (A28) to the seat frame (A26).
- (c) Use screws (55) to secure the seat back plate (54) to the seat back mount and then secure the seat back (A25) to the seat back plate (54) with screws (53) as shown.

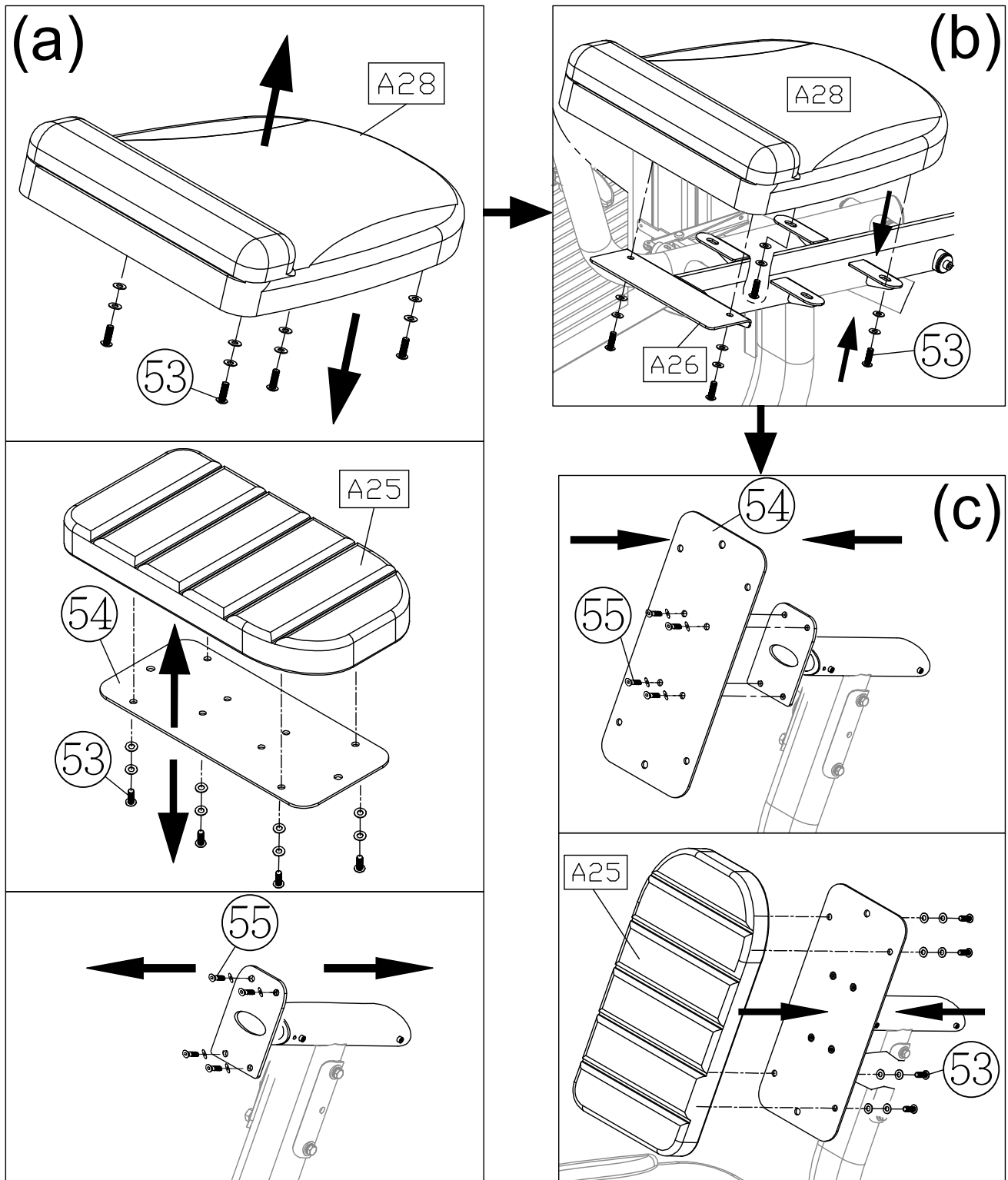

STEP 13 Covers Installation

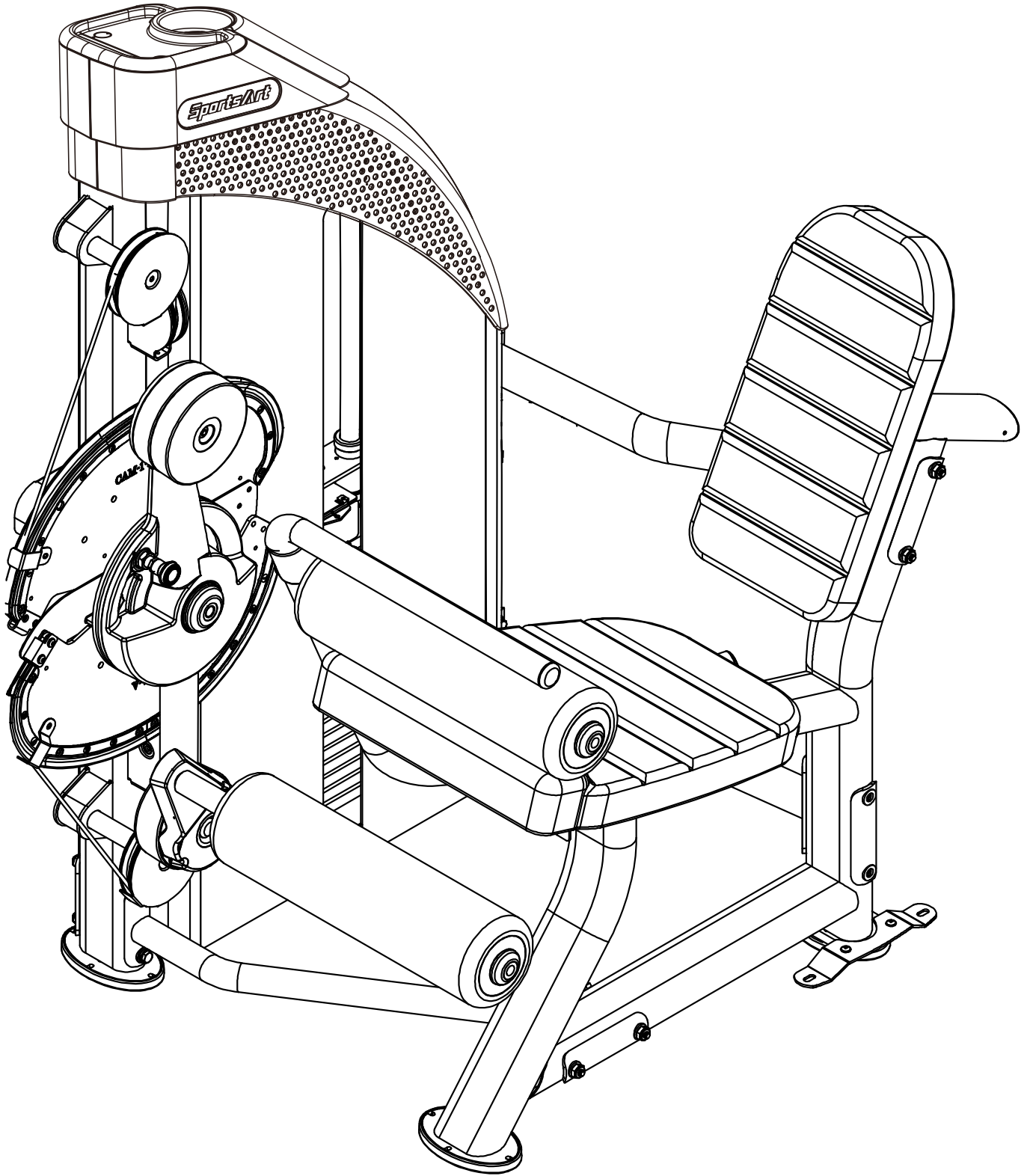

STEP 13 Covers Installation (CONT.)

Follow instructions (a) through (g) to install the front and rear covers.

(a) Remove screws (56) from the main frame.

(b) Install the square snap bushings (17) to the anchor brackets of shroud (square hole) (A8-1). Secure the anchor brackets of shroud (square hole) (A8-1) with the square snap bushings (17) to the front and back of the upper crossmember assembly of weight stack tower with screws (61). Secure the anchor brackets of shroud (tapped hole) (A8-2) to the front and back of the lower crossmember assembly of weight stack tower with screws (61).

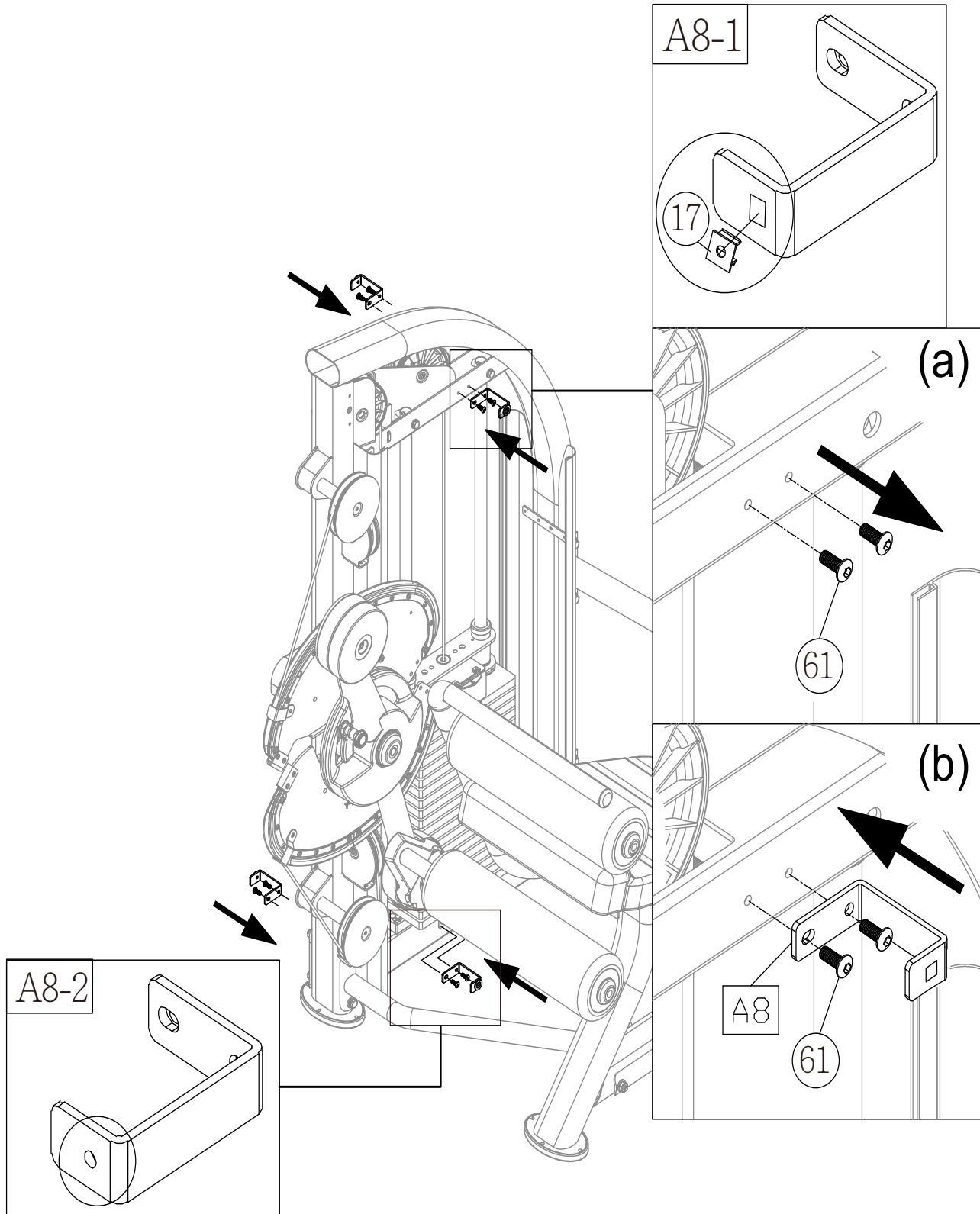

STEP 13 Covers Installation (CONT.)

- (c) Take out the stack fork (A6) and place it on the upper stack carriage set (32) as shown to avoid damaging to the cover.
- (d) Slide the front cover (A13) from the top down into the cover support plates' grooves.
- (e) Secure the lower shroud with the screw (65).
- (f) Put the stack fork (A6) back in place.

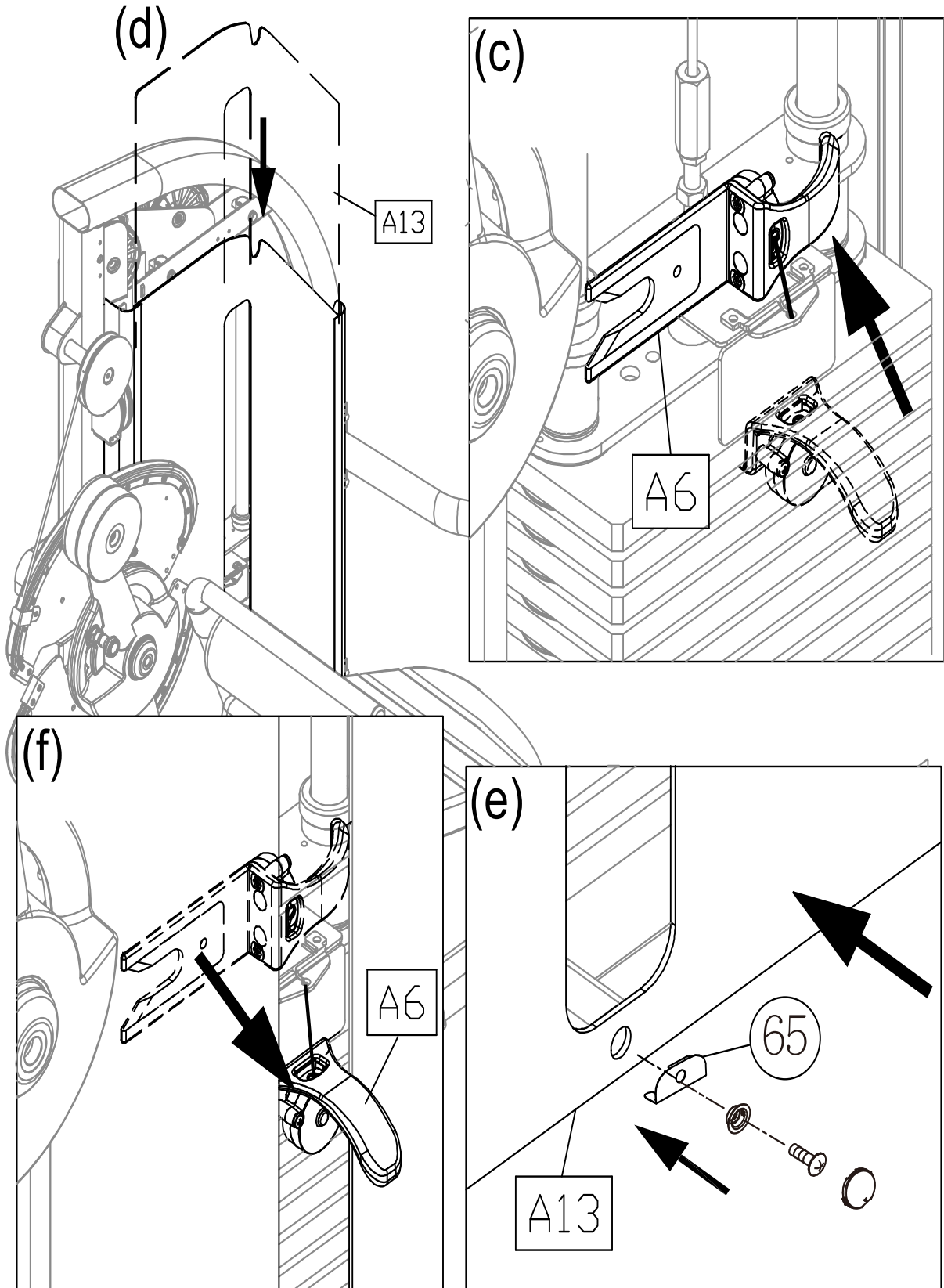

STEP 13 Covers Installation (CONT.)

- (g) Slide the rear cover (A12) from top down into the cover support plates' grooves and then secure the assembly with screw (65) as shown.

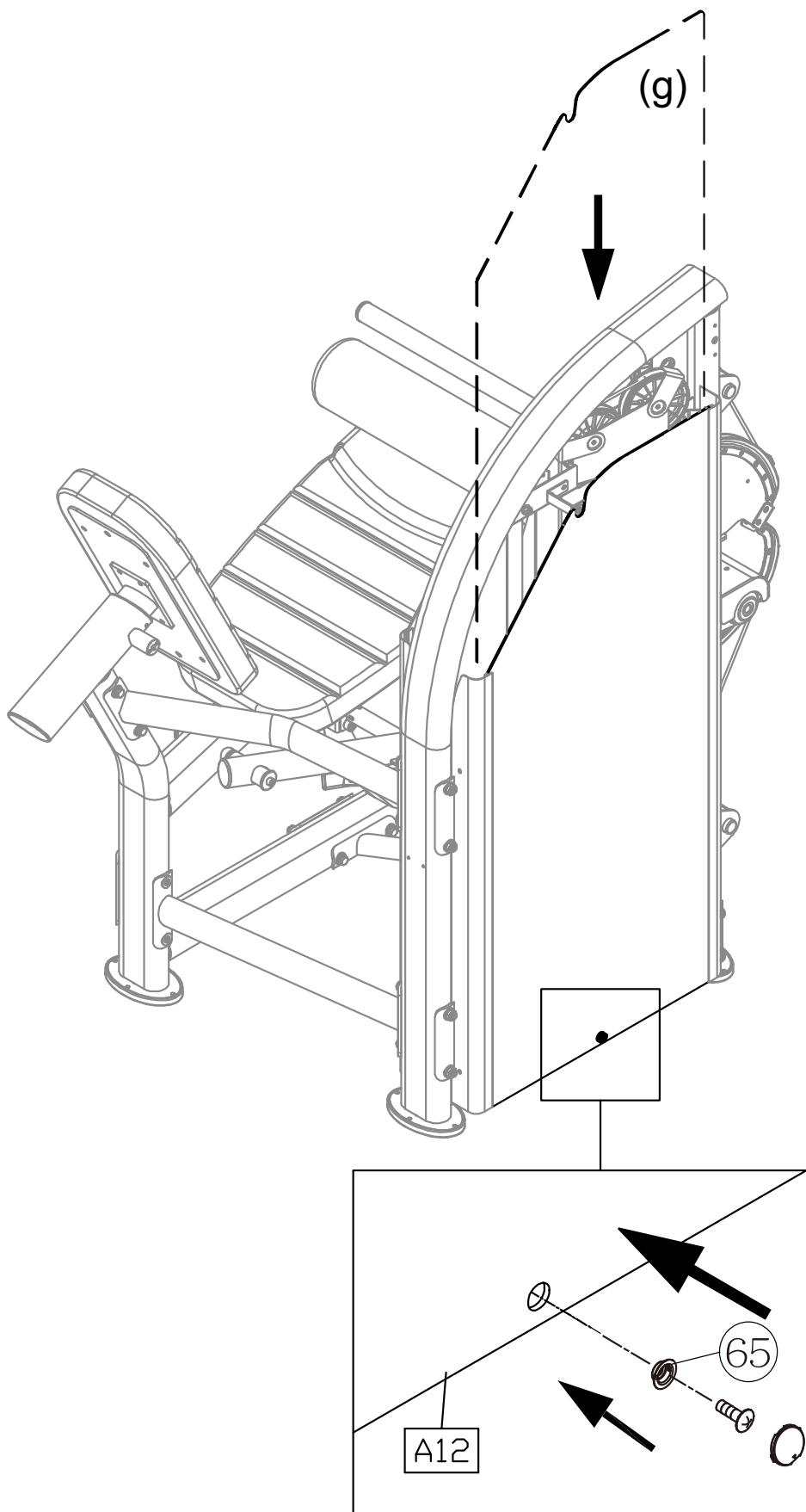

STEP 14 Install Plastic Cover

- (a) Install the square snap bushing (17) and fastener (73) to the anchor bracket (A51) and remove the screws (66) on the main frame. Secure the anchor bracket (A51) to the main frame with the screws (66).
- (b) Secure the left/right perforated boards (A1) to the main frame with the screws (70).
- (c) Assemble the right side cover (A2) and the front cover A (A27) together before installing to the main frame.
- (d) Assemble the left side cover (A2) and the front cover A (A27) together and then embed the top cover (A50), which is the water bottle holder, at an oblique angle.
- (e) Secure the top cover (A50) to the main frame with the screws (71) and then install the round screw caps (72).

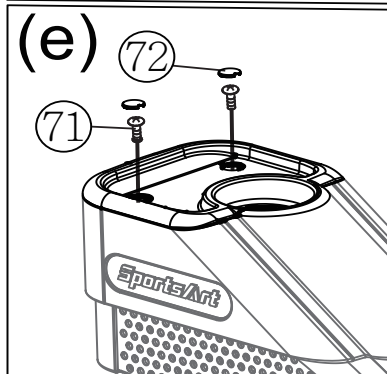
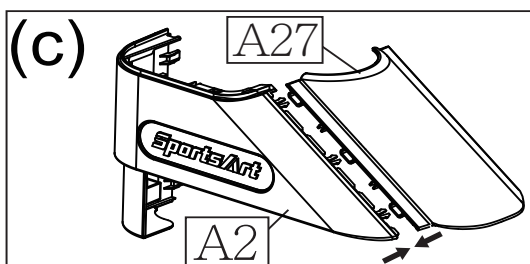
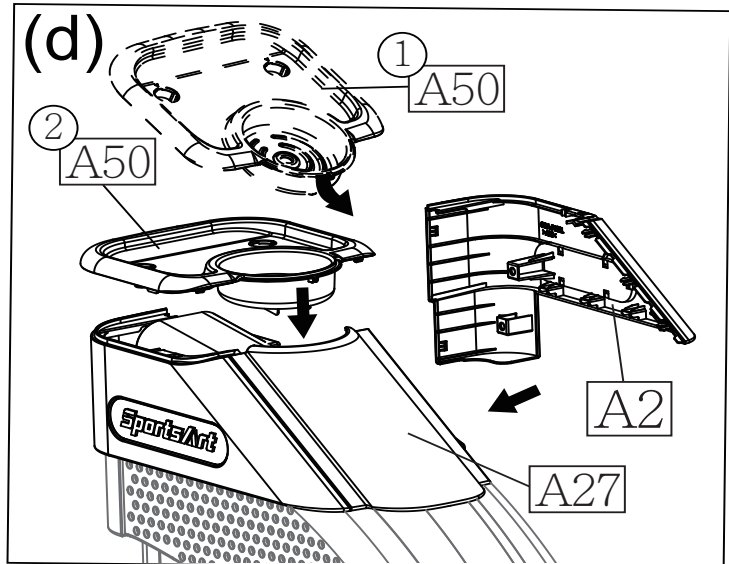
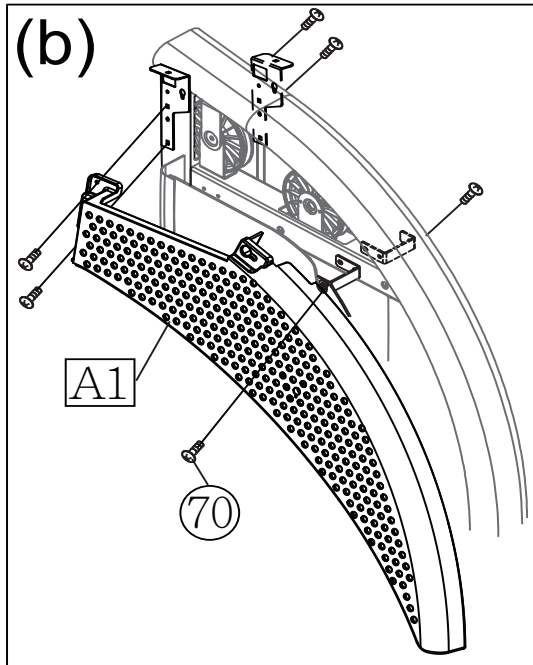
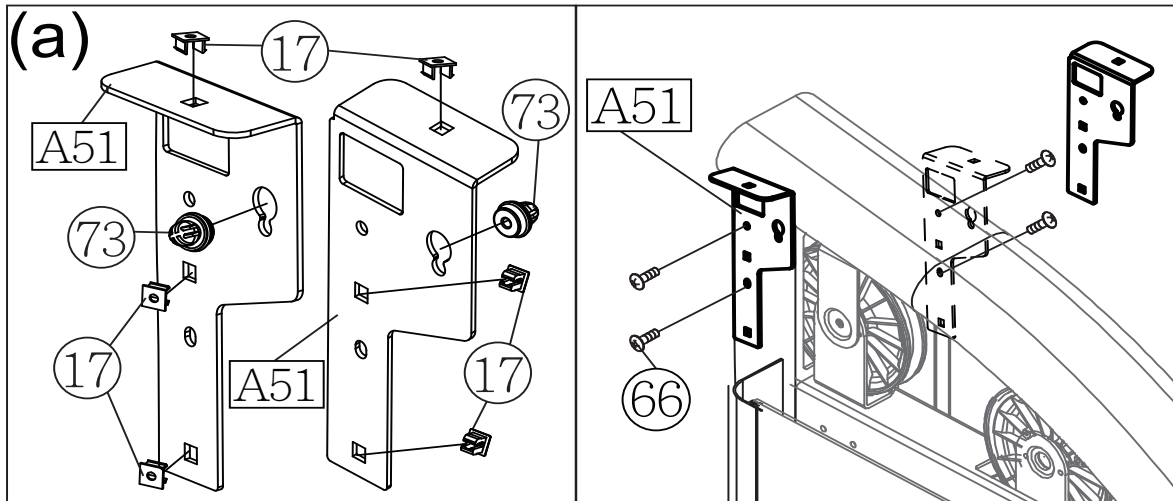

STEP 15 Install Cap Nut

Install the cap nuts to the corresponding positions according to the following numbers.

*The cap nuts in the following table are for reference only. The provided cap nuts will depend upon the needs of the different devices.

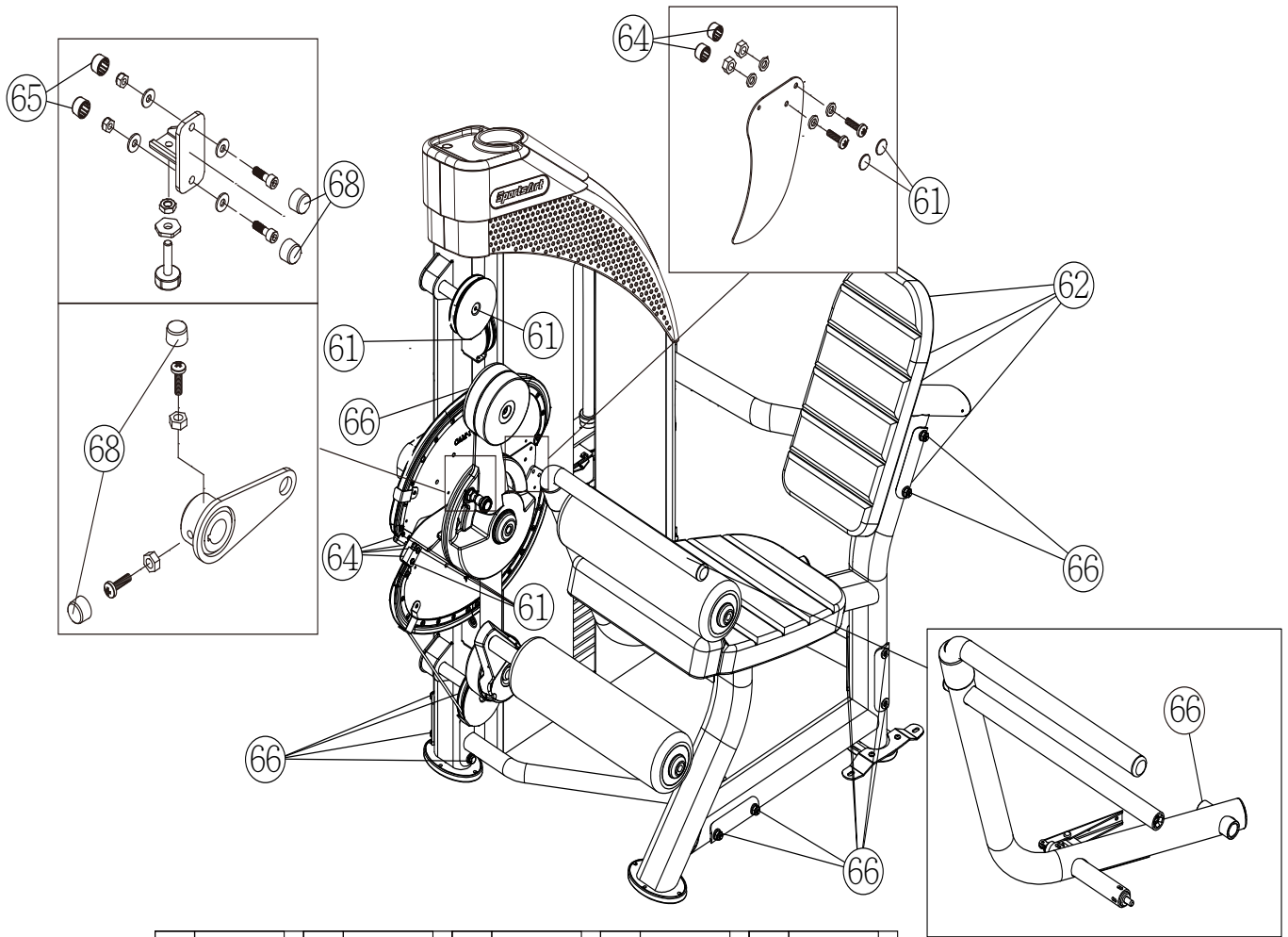

60 GBA-P019	61 GBA-P024	62 GBA-P014	63 GFA-P136	64 GBA-P018
65 GBA-P017	66 GBA-P016	67 TAO-P096A	68 GFA-P137	69 GFA-P138

STEP 16 Secure the Product

- (a) Remove screws (56) from the floor fixing bracket (A15).
- (b) Insert the U clip (A16) onto the machine (Make sure the U clip with the correct side downward as shown below), and then secure the floor fixing bracket (A15) with screws (56).
- (c) Secure the floor fixing bracket to the floor with the floor fixing bolt, nut and washer as shown to make sure the machine is firmly fixed to the floor when operating.
(Note: The screw hole of floor fixing bracket is $\varnothing 9\text{mm}$, please make sure using the suitable floor fixing bolt and drilling the proper hole on the floor.)

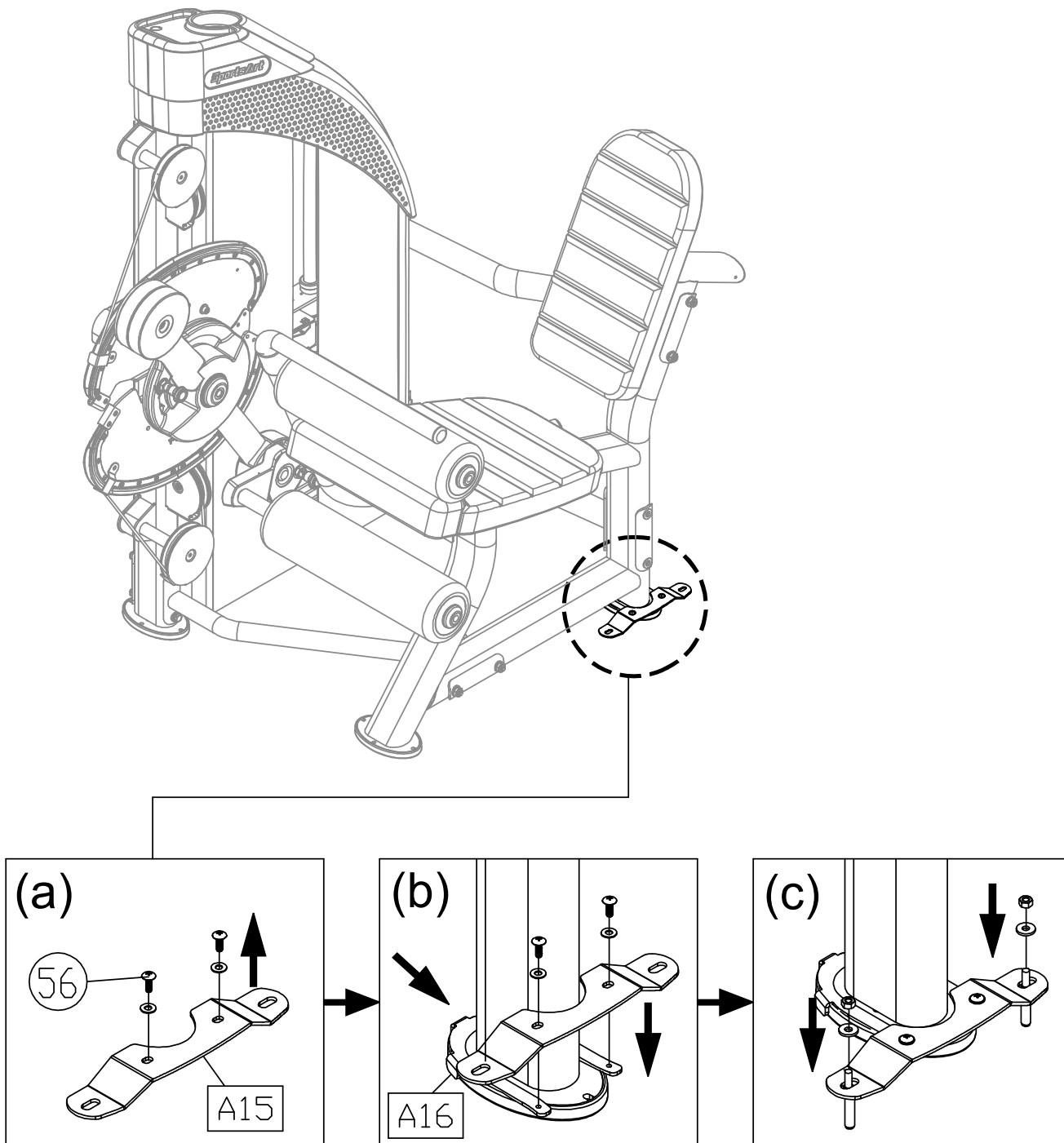

STEP 17 Level the Product

If the product is installed on an uneven surface to cause the instability of the product, place the support spacer under the foot pad to make sure its stability.

(A few support spacers are provided in the packaging of this product.)

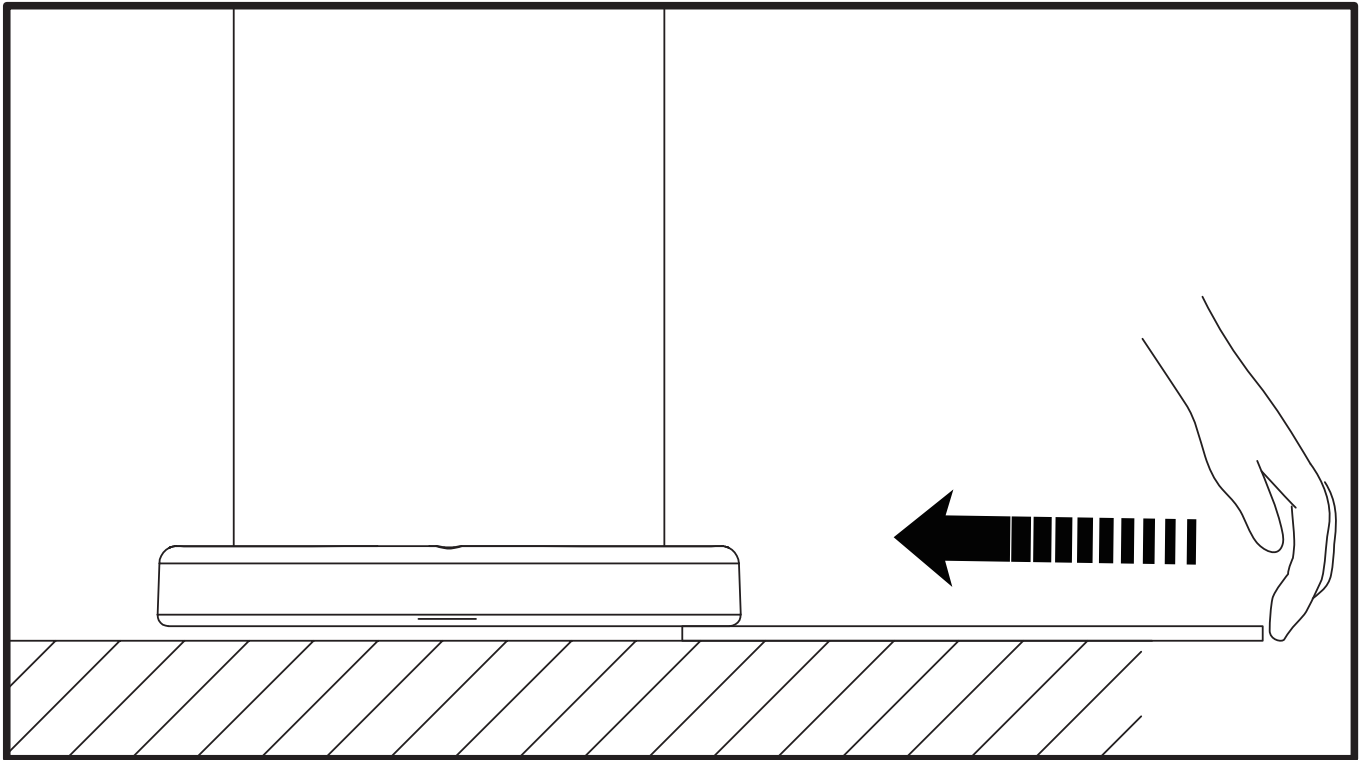

STEP 18 Stack Fork Inspections

- * Please follow operating instructions on the product sticker to test operation and confirm that the equipment is working properly.
- * Insert the stack fork to make sure that every weight plate can be engaged easily.
- * Insert the stack fork at the heaviest weight setting at which you can safely operate the equipment.
- * Exercise to lift the stack several times, and then inspect the cable for proper tightness. If necessary, make adjustments according to the instructions “Cable adjustment” of this manual.
- * Ensure that anyone who is not operator does not near the equipment when testing.

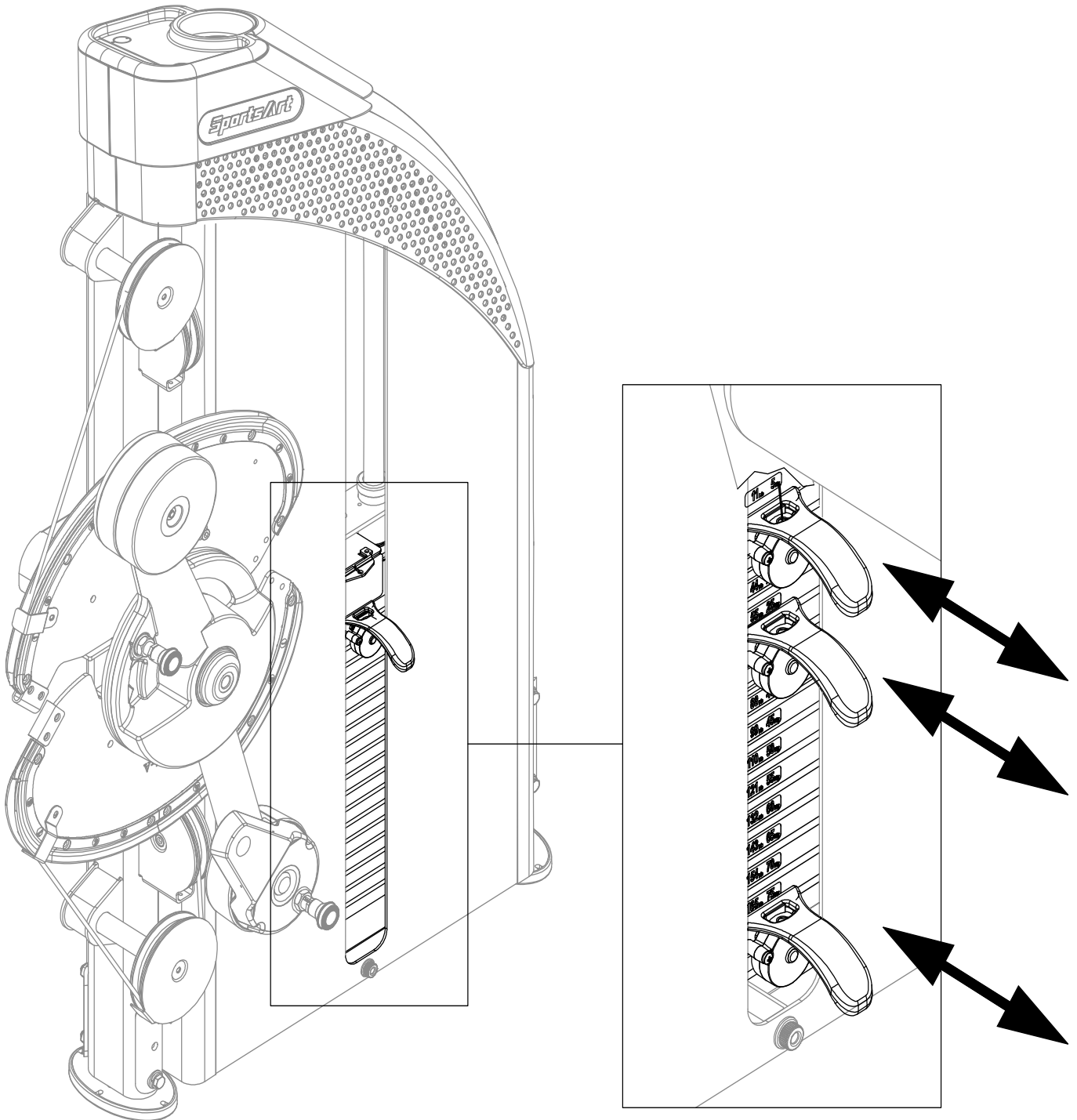

STEP 19 Unit Inspection

After completing the assembly or regular maintenance, please follow instructions (a) through (c) below to inspect the unit. If the unit is disassembled or has been damaged in any way, it might cause injuries or cause the unit to fail.

- (a) Make sure the unit is steady and on a level surface. If the unit is not steady, make adjustments according to the instructions “Level the Unit” of this manual.
- (b) Make sure all parts are assembled and all fasteners are tightened.
- (c) Please follow operating instructions to test operation and confirm that the equipment is working properly. (Please refer to “Operate the Product” of this manual.)

5. OPERATION INSTRUCTION

OPERATION **Operating the Product**

- * Pull out the knob to adjust the cylindrical cushion arm position. You can rotate and secure the cylindrical cushion arm as desired for use within a 360 degree range. When released, the knob automatically engages to secure the position.

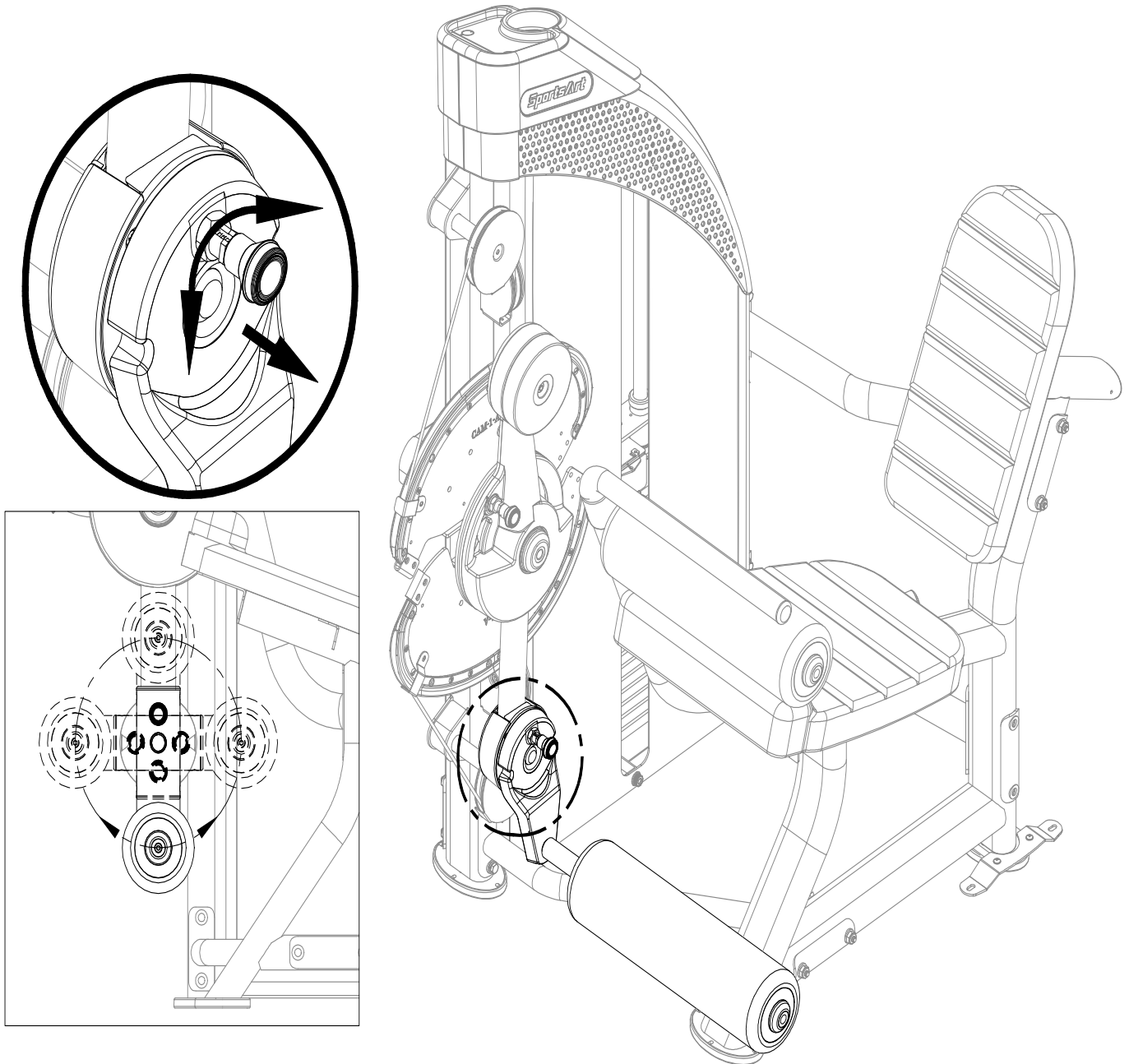

OPERATION Operating the Product (CONT.)

- * Pull out the knob on the rotator arm of CAM. Place the rotator as desired for use. When released, the knob automatically engages to secure the position.

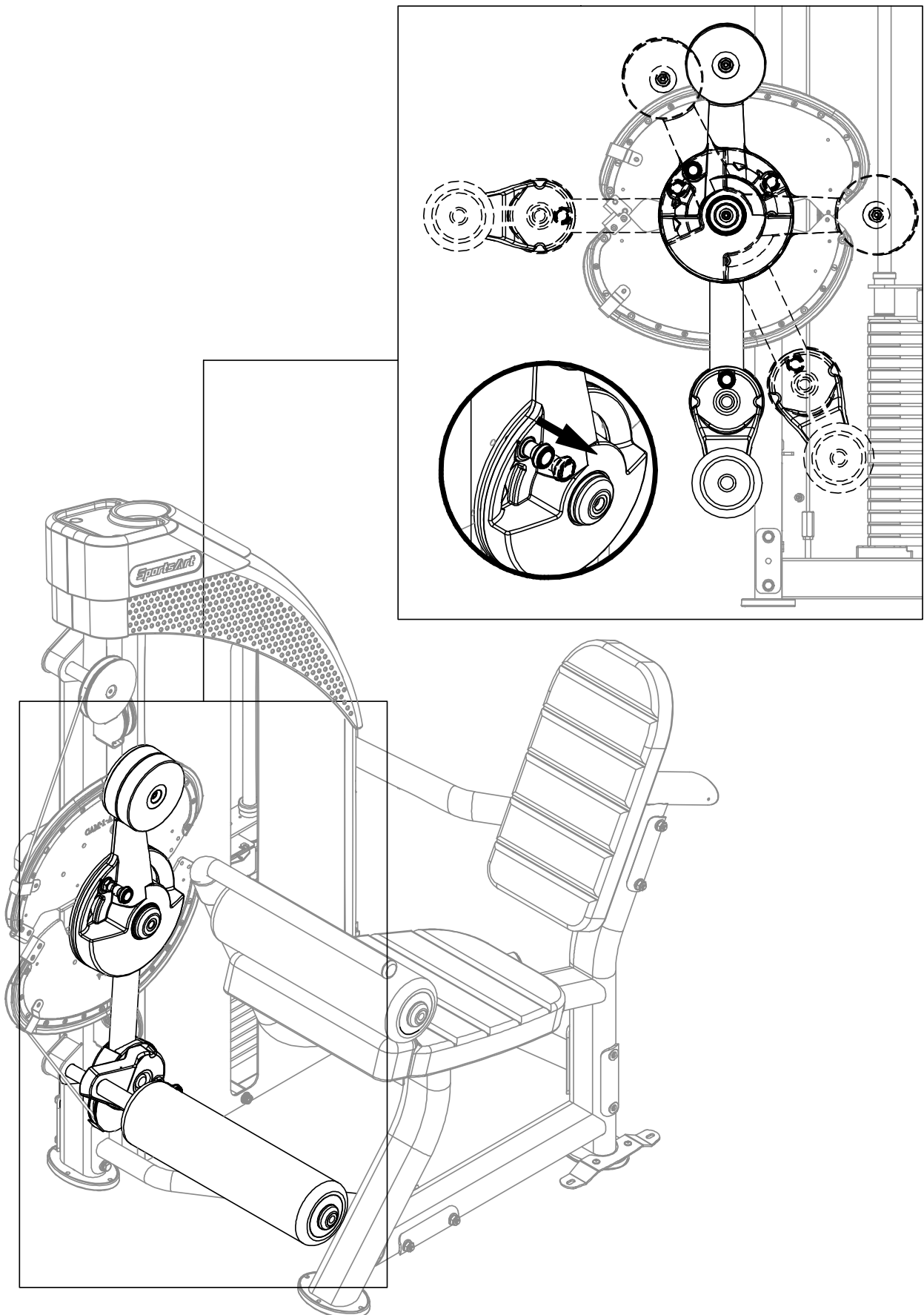

OPERATION Operating the Product (CONT.)

* With your left hand on the handle and your right hand on the release lever, adjust the cushion height.

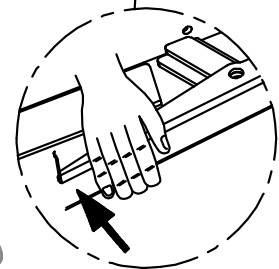
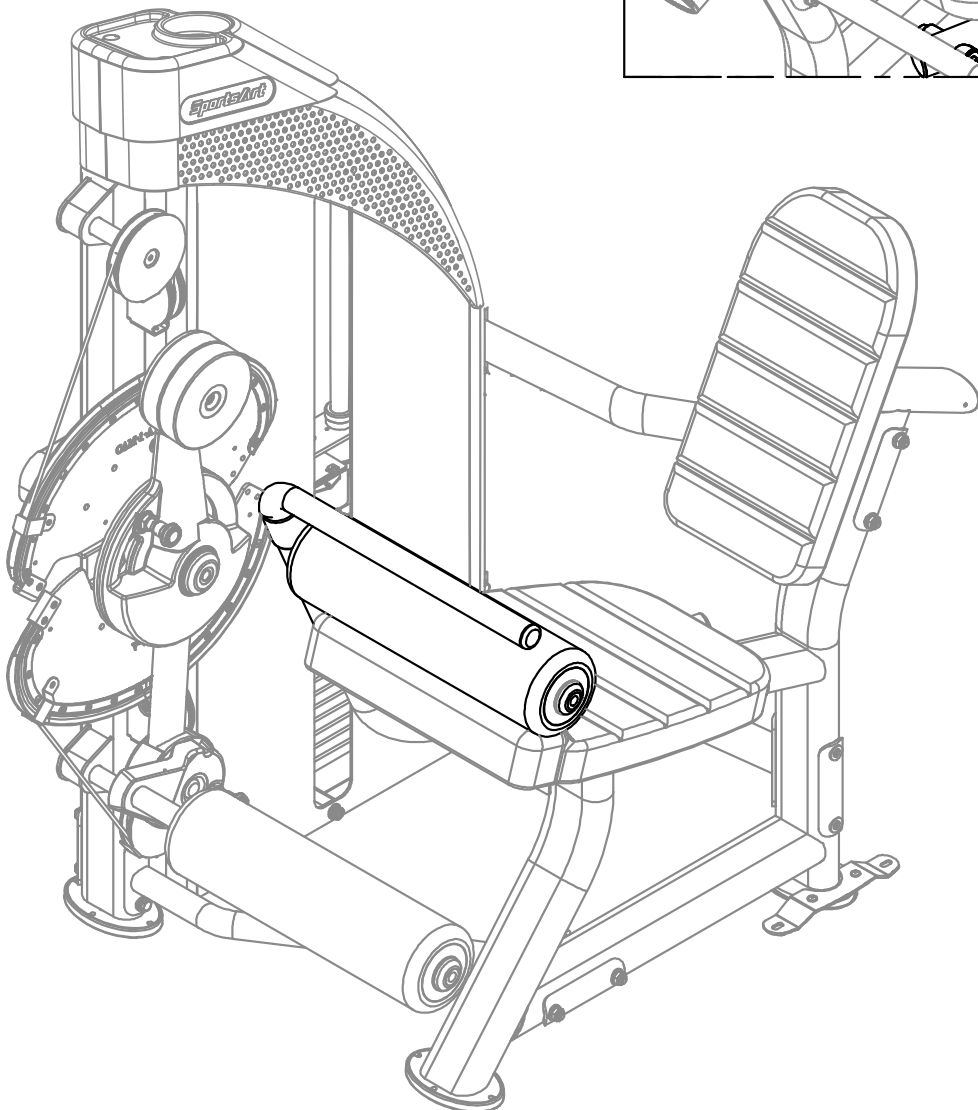
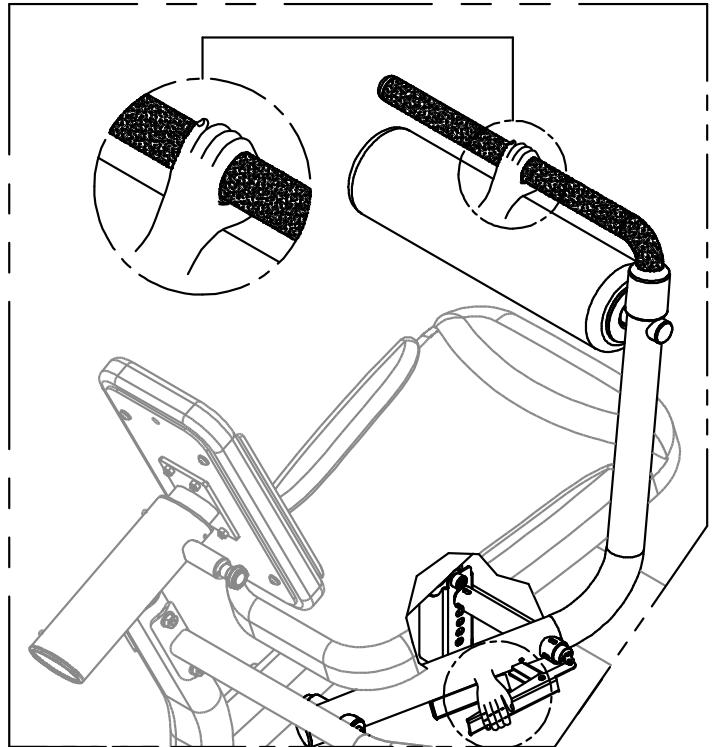
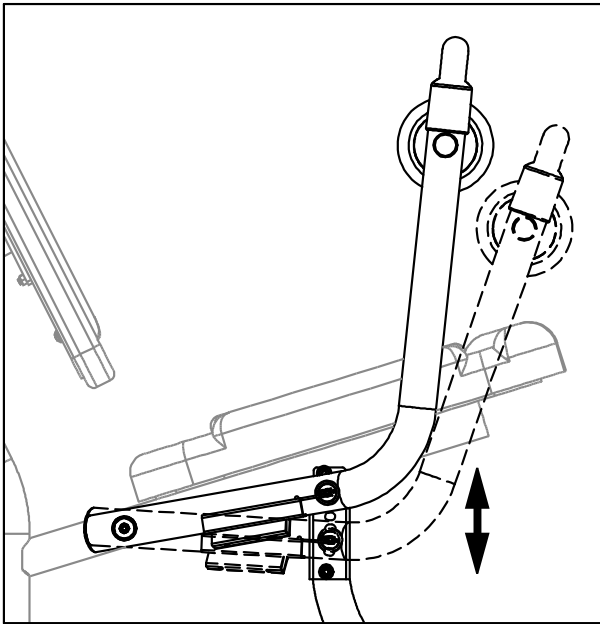

OPERATION Operating the Product (CONT.)

* To move the seat back position toward yourself, simply pull it. To move the seat back away from yourself, pull the knob and press the seat back.

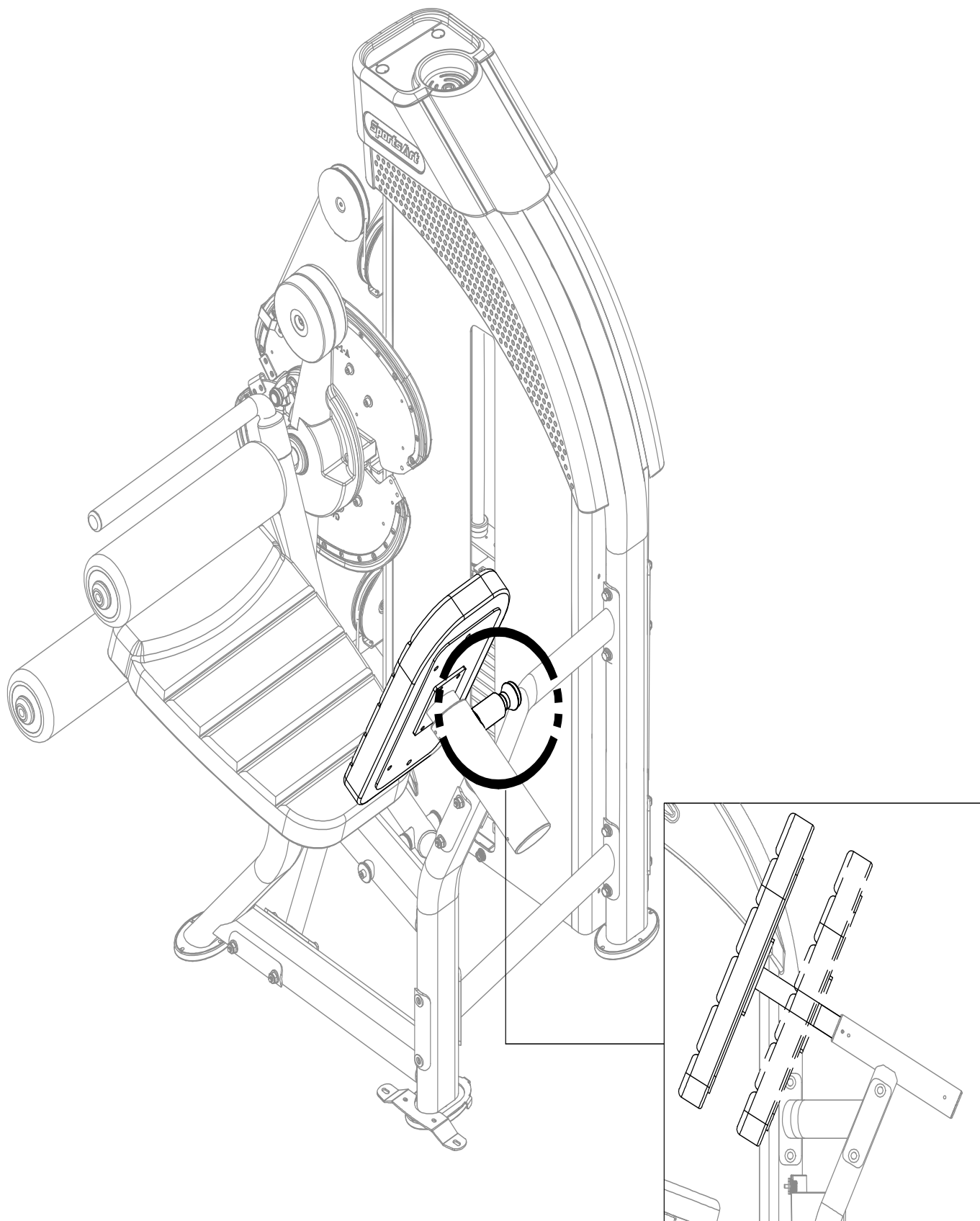

OPERATION Exercising Instructions

- (a) Select the appropriate weight plates according to your recommended exercise level.
- (b) Adjust the seat back and the cylindrical cushion to the most comfortable position and make sure the knob is engaged to secure the position.
- (c) Perform the exercise in a controlled manner. Inhale when pushing up against resistance and exhale when returning to original position.
- * Please exercise within the range of your skill and training. DO NOT work to exhaustion.
- * All users operate this machine must be supervised under coaches instructions at all times in order for safety.

Please follow the operating instructions as below to test operation.

- (a) Please follow operating instructions on the product sticker to test operation and make sure the equipment is working properly.
- (b) Insert the stack fork at the heaviest weight setting at which you can safely operate the equipment. Exercise to lift the stack several times. Then inspect the cable for proper tightness. If necessary, make adjustments according to the instructions in this manual.

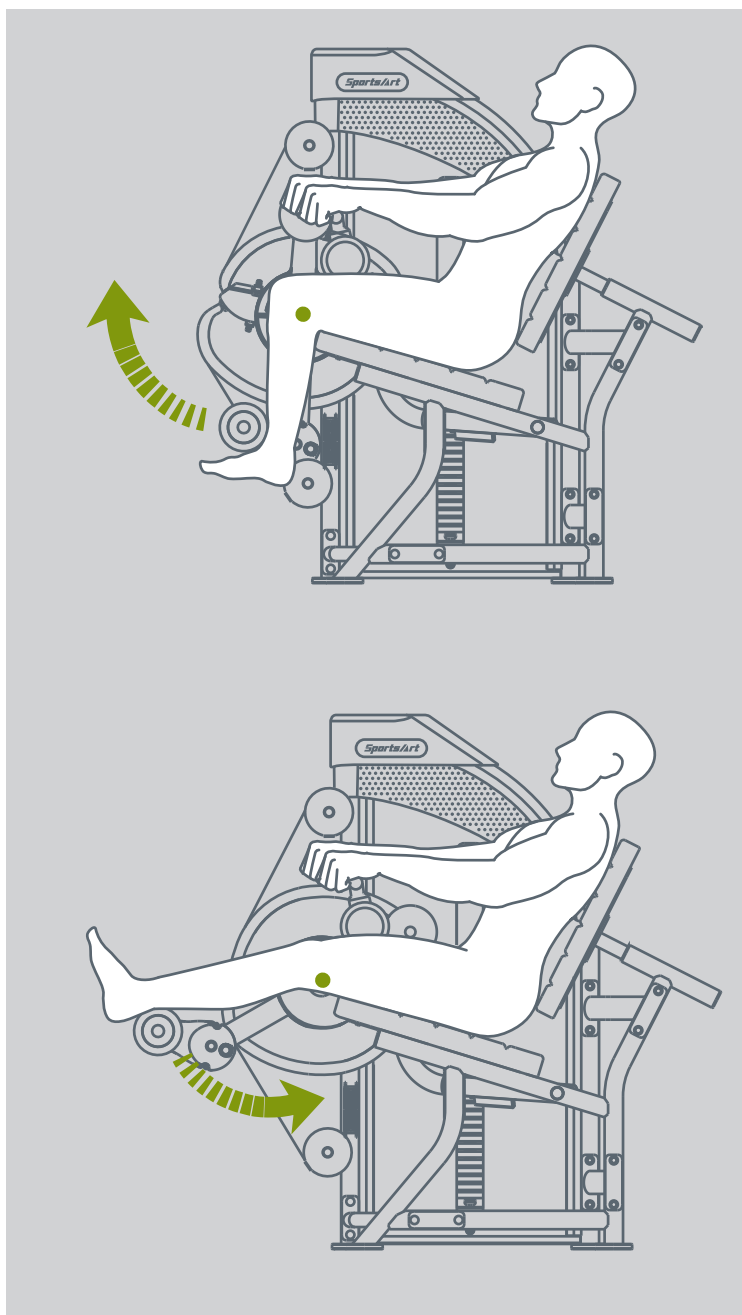

OPERATION Safety Operating Area

- (a) Safety clearance required as shown below. Do not allow people to be near this area when operating.
- (b) Noise emission under load is higher than without load.
- (c) Over exercising or improper workout position may result in serious injury.
- (d) This product is intended for exercise legs.

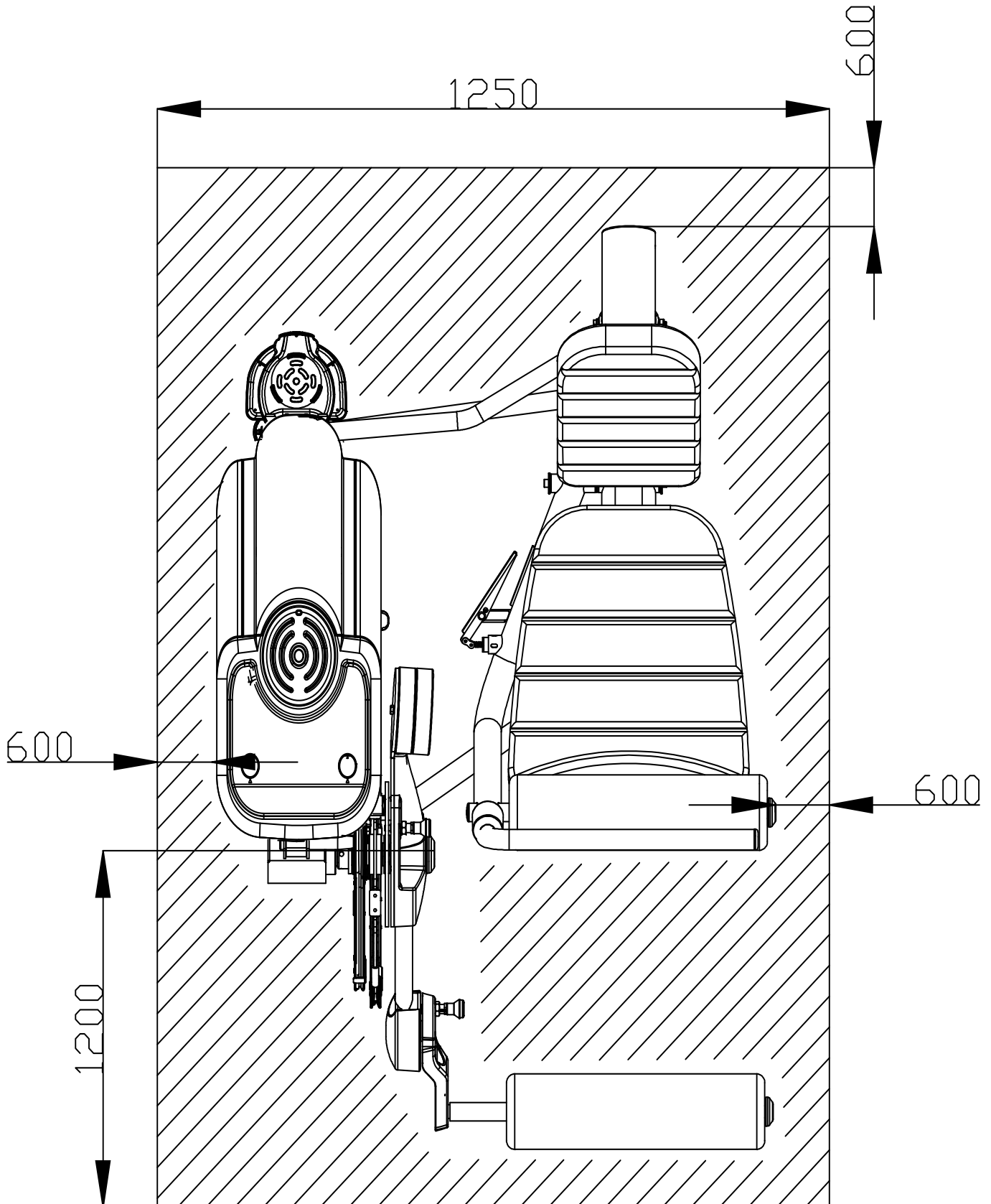

6. MAINTENANCE

This section covers maintenance topics and includes a maintenance schedule, task list, and log.

MAINTENANCE Safety Precautions

- Please follow standard safety precautions when servicing this product.
- Do NOT use a water damp towel to clean the product and do perform the following maintenances.
- Do NOT use cleaners with alcohol, ammonia, or other damaging chemicals. The use of such chemicals can damage the product and void the warranty. Never spray or pour any liquid directly onto the product. Doing so can damage components and void the warranty.
- Use a clean, lint-free towel, dampened with a mixture of Simple Green® all-purpose cleaner, to thoroughly clean the handlebar and the console.
- This product has moving parts that can be hazardous. Exercise caution when maintaining, operating, or moving this product.
- Do not use accessories or parts that are not specifically recommended by the manufacturer (SportsArt) . Such parts might cause injuries or cause the unit to fail and void the warranty. We are not responsible for any safety issue that arises due to the misuse of accessories or parts. At the same time, we will terminate the warranty terms of this equipment.
- Maintenance and repair must be performed by trained service personnel only. Improper maintenance would not only damage the machine, but may also present a danger to the exerciser.
- Keep this product out of use until maintenance is completed.

MAINTENANCE Guide Rod Cleaning and Lubricating

1. Apply lubricant to the guide rods every week. Procedure:
 - (a) Put some lubricant on a clean, lint-free cloth. Rub the lubricated cloth on the guide rods.
 - (b) Load the upper stack carriage set. Exercise to test operation.
 - (c) Repeat steps (a) and (b) 2-3 times. (Note: the cloth should be lint-free.)
2. After lubricating the guide rods, inspect cable tightness. Refer to the manual, and adjust it if necessary.

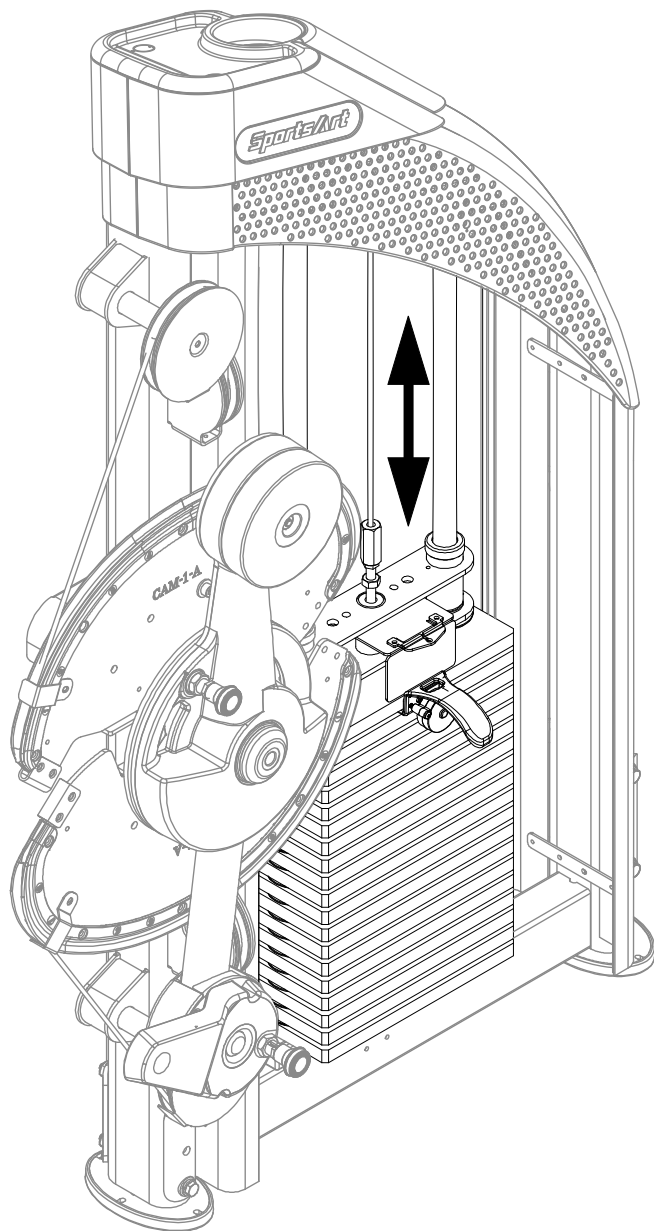
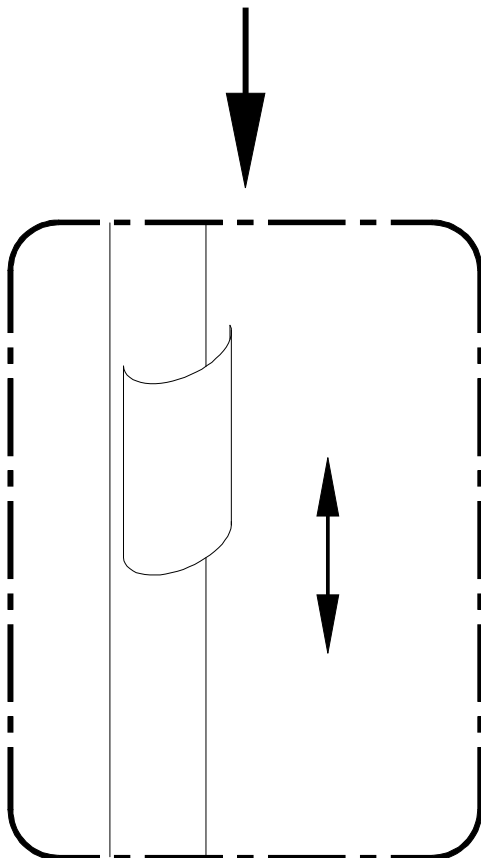
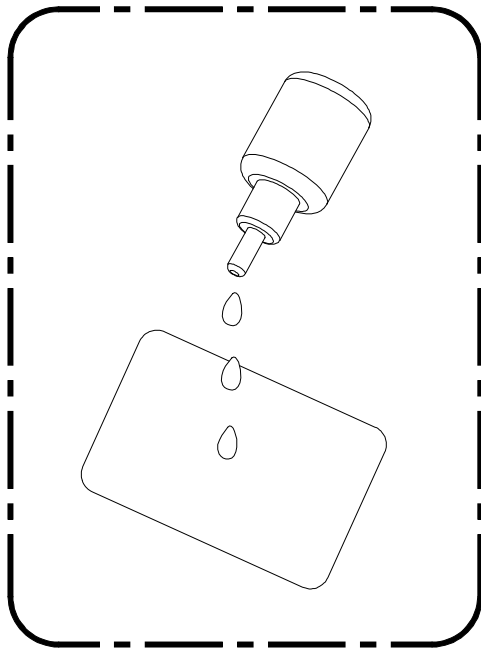

MAINTENANCE Schedule

If there is a need for maintenance of components, please visit the SportsArt website.

cleaning requirements

1.directive 93/42/CEE

2.directive biocide 98/8/CEE

The disinfectant has to be in compliance with Medical Device Directive 93/42/EEC (MDD) and Biocidal Products Directive 98/8/EC (BPD).

It is suited for sensitive synthetic surfaces such as synthetic leather, polycarbonate (PC), acrylic glass and polysulfone, and for the keyboards and control panels.

	Area	Day	Week	Month	Quarter	Year	Notes
1	Exterior	●					Clean.
2	Screws	●					Inspect for looseness and secure if necessary.
3	Test	●					Check for proper equipment operation.
4	Cushions	●					Use dampened cloth to clean.
5	Cable		●				Check for damage or wear. Replace it if necessary.
6	Guide Rod		●				Clean and lubricate.

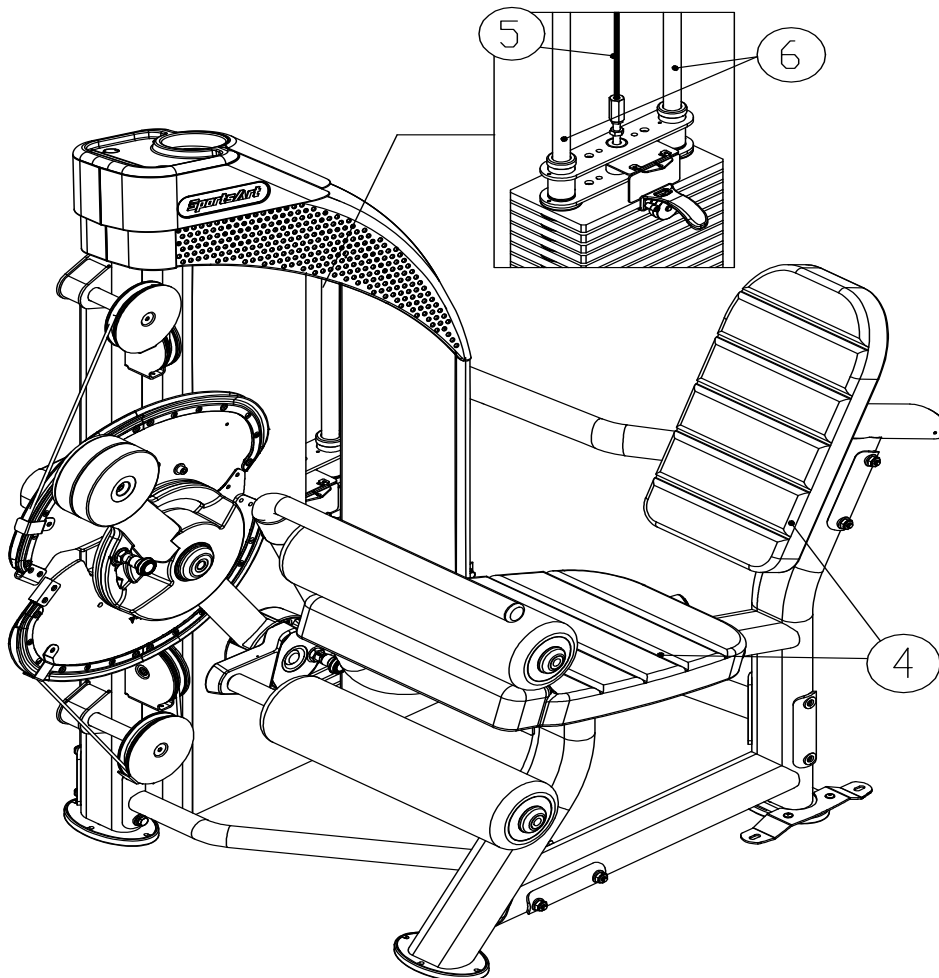

MAINTENANCE Task List

Like cars, fitness products require maintenance. Regular maintenance extends product life, and failure to maintain products can void the manufacturer's warranty. Copy the maintenance log sheet, and record maintenance work for each fitness product.

Daily tasks

1. Use a clean, lint-free towel to wipe down the product exterior.
2. Inspect all screws. Secure if necessary.
3. Make sure the machine is working properly.
4. Wipe all cushions clean with a damp cloth.

Weekly tasks

1. Check the cable for damage or tear.
2. Clean and lubricate the guide rods.

Caution

- Please follow standard safety precautions when servicing this product.
- Do NOT use cleaners with alcohol, ammonia, or other damaging chemicals. The use of such chemicals can damage the product and void the warranty. Never spray or pour any liquid directly onto the product. Doing so can damage components and void the warranty.

MAINTENANCE One-Year Maintenance Log

Facility: _____ Supervisor: _____

Product model number: _____ Serial number: _____

Start date: _____ End date: _____

Daily Tasks	Weeks 1-7	Weeks 8-14	Weeks 15-21	Week 22-28
Completed	<input type="checkbox"/>	<input type="checkbox"/>	<input type="checkbox"/>	<input type="checkbox"/>

Daily Tasks	Week 29-35	Week 36-42	Week 43-49	Week 50-52
Completed	<input type="checkbox"/>	<input type="checkbox"/>	<input type="checkbox"/>	<input type="checkbox"/>

Weekly Tasks	Weeks 1-7	Weeks 8-14	Weeks 15-21	Weeks 22-28
Completed	<input type="checkbox"/>	<input type="checkbox"/>	<input type="checkbox"/>	<input type="checkbox"/>

Weekly Tasks	Weeks 29-35	Weeks 35-42	Weeks 43-49	Weeks 50-52
Completed	<input type="checkbox"/>	<input type="checkbox"/>	<input type="checkbox"/>	<input type="checkbox"/>

Monthly tasks	1	2	3	4	5	6	7	8	9	10	11	12
Completed	<input type="checkbox"/>	<input type="checkbox"/>	<input type="checkbox"/>	<input type="checkbox"/>	<input type="checkbox"/>	<input type="checkbox"/>	<input type="checkbox"/>	<input type="checkbox"/>	<input type="checkbox"/>	<input type="checkbox"/>	<input type="checkbox"/>	<input type="checkbox"/>

Quarterly Tasks	Quarter 1	Quarter 2	Quarter 3	Quarter 4
Completed	<input type="checkbox"/>	<input type="checkbox"/>	<input type="checkbox"/>	<input type="checkbox"/>

Yearly Tasks	Year 1
Completed	<input type="checkbox"/>

Notes: _____

7. CONSIGNES DE SÉCURITÉ IMPORTANTES

Le produit SportsArt a été conçu et fabriqué afin d'assurer une sécurité optimale. Cependant certaines précautions s'appliquent chaque fois que vous utilisez votre produit.

- Lisez entièrement le manuel avant l'assemblage et l'utilisation. Veuillez aussi noter les consignes de sécurité suivantes:
- Veuillez lire attentivement les instructions et installer le produit selon les instructions.
- Assemblez et faites fonctionner le produit sur une surface solide et plane; NE PAS l'utiliser à l'extérieur ou près de l'eau.
- En aucun cas, ne laissez des enfants à proximité ou sur le produit.
- Vérifiez le tapis de course avant chaque utilisation. Assurez-vous que toutes les pièces sont assemblées et que tous les éléments de fixation sont serrés. NE PAS utiliser le produit si l'appareil est démonté de quelque façon.
- Gardez vos mains loin des pièces mobiles.
- Portez des vêtements d'entraînement appropriés; NE PORTEZ PAS de vêtements amples. NE PORTEZ PAS de chaussures à semelles en cuir ou à talons hauts. Attachez les cheveux longs.
- Soyez prudent lors du montage et démontage de l'appareil.
- NE PAS utiliser d'accessoire non spécifiquement recommandé par le fabricant. Car cela pourraient provoquer des blessures ou entraîner une panne de l'appareil.
- Débranchez l'appareil de la prise avant l'entretien ou la suppression de toute pièce.
- Une surveillance étroite est nécessaire quand le produit est utilisé par ou à proximité d'enfants, de malades ou de personnes handicapées.
- Utilisez ce produit uniquement pour l'usage prévu dans ce manuel.
- La limite de poids de l'utilisateur pour le produit est de 227 kg, 500 lb.
- Ce produit n'est pas destiné à être utilisé par des personnes (y compris des enfants) dont les capacités physiques, sensorielles ou mentales sont réduites ou qui ne disposent pas de l'expérience ou du savoir nécessaires, sauf si celles-ci ont au préalable été formées eu égard à l'utilisation de produit par une personne responsable de leur sécurité.
- Les enfants doivent être encadrés afin d'empêcher qu'ils ne jouent avec le produit.

ATTENTION

Si vous ressentez une douleur ou si vous avez une sensation anormale, ARRÊTEZ VOTRE ENTRAÎNEMENT et consultez immédiatement votre médecin. Entraînez-vous à votre niveau d'exercice recommandé. NE PAS s'entraîner jusqu'à l'épuisement. Avant de commencer un programme d'exercice, vous devriez consulter votre médecin. Il est recommandé de faire un examen physique complet. Dans ce manuel, les mots "gauche" et "droit" sont utilisés en référence aux pièces et au produit. Comme tels, les mots "gauche" et "droit" font respectivement référence aux côtés gauche et droit de l'exerciseur. De même pour plus de concision, le mot «vis» est utilisé dans certains cas où des rondelles, des vis et autres matériels sont associés.

DF-300 Leg Extension / Leg Curl

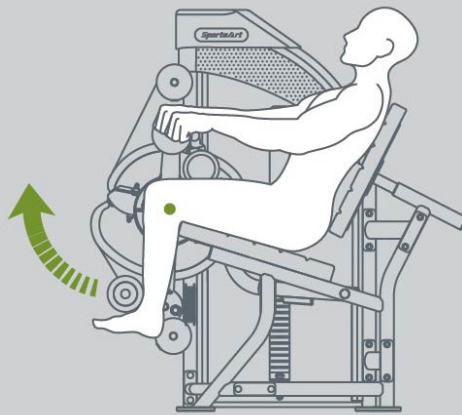

Leg Extension

- 1 Select a weight that enables you to perform the exercise properly.
- 2 Adjust rotator arm to bottom position for leg extension.
- 3 Adjust back support so knees are aligned with the pivot point.
- 4 Position lower roller pad against the shins. Place back against back pad.
- 5 Grasp handles and extend legs in a controlled motion. Exhale when pushing against resistance.

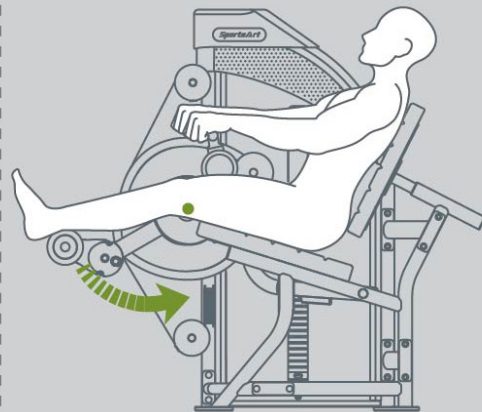

Leg Curl

- 1 Select a weight that enables you to perform the exercise properly.
- 2 Adjust rotator arm to top position for leg curl.
- 3 Adjust back support so knees are aligned with the pivot point.
- 4 Place upper roller pad securely against your thighs.
- 5 Grasp handles and curl legs beneath your body in a controlled motion. Exhale when pushing against resistance.

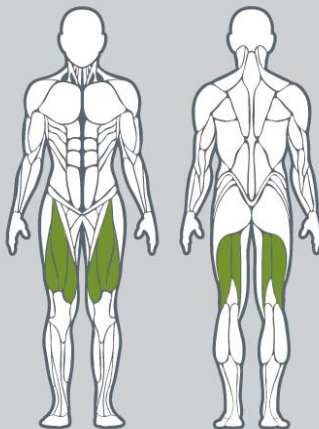

www.gosportsart.com

CAUTION

Do not use this machine if you are unfamiliar or do not know how to operate it. Do not allow people near this machine when in use. Keep clear of parts not intended for contact during exercise. For your safety, exhale while you exert force. Never allow unattended children on or near fitness equipment.

Your Authorized Distributor