

DF-307 OWNER'S MANUAL CONTENTS

1. INTRODUCTION	2
2. SAFETY PRECAUTIONS	3
3. LIST OF PARTS	4
4. ASSEMBLE THE PRODUCT	7
STEP 1 Cover Support Plate, Connector and Front Support Installation.....	7
STEP 2 Weight Stack Installation	10
STEP 3 Cable Adjustment	13
STEP 4 Apply the Weight Stack Sticker	15
STEP 5 Seat Bottom Installation	16
STEP 6 Rear Cover Installation	17
STEP 7 Install Plastic Cover	19
STEP 8 Handles Installation	20
STEP 9 Storage Tray Installation	21
STEP 10 Install Cap Nut	22
STEP 11 Secure the Product	23
STEP 12 Stack Fork Inspections	24
STEP 13 Unit Inspection	25
5. OPERATION INSTRUCTION	26
OPERATION Operating the Product	26
OPERATION Exercising Instructions	27
OPERATION Safety Operating Area	28
6. MAINTENANCE	29
MAINTENANCE Safety Precautions	29
MAINTENANCE Guide Rod Cleaning and Lubricating	30
MAINTENANCE Schedule	31
MAINTENANCE Task List	32
MAINTENANCE One-Year Maintenance Log	33
7. CONSIGNES DE SÉCURITÉ IMPORTANTES	34
8. APPENDIXES	35
APPENDIXES Exploded Diagram	35

1. INTRODUCTION

Congratulations on the purchase of a high quality SportsArt product, the DF-307 Assisted Chin and Dip machine. Constructed of high quality materials and designed for years of reliable performance, this product was made for full commercial use.

Before this product is assembled or operated, we recommend that you familiarize yourself with this manual. Understanding the correct assembly and operation of this product will help ensure that exercisers obtain their fitness goals safely and successfully.

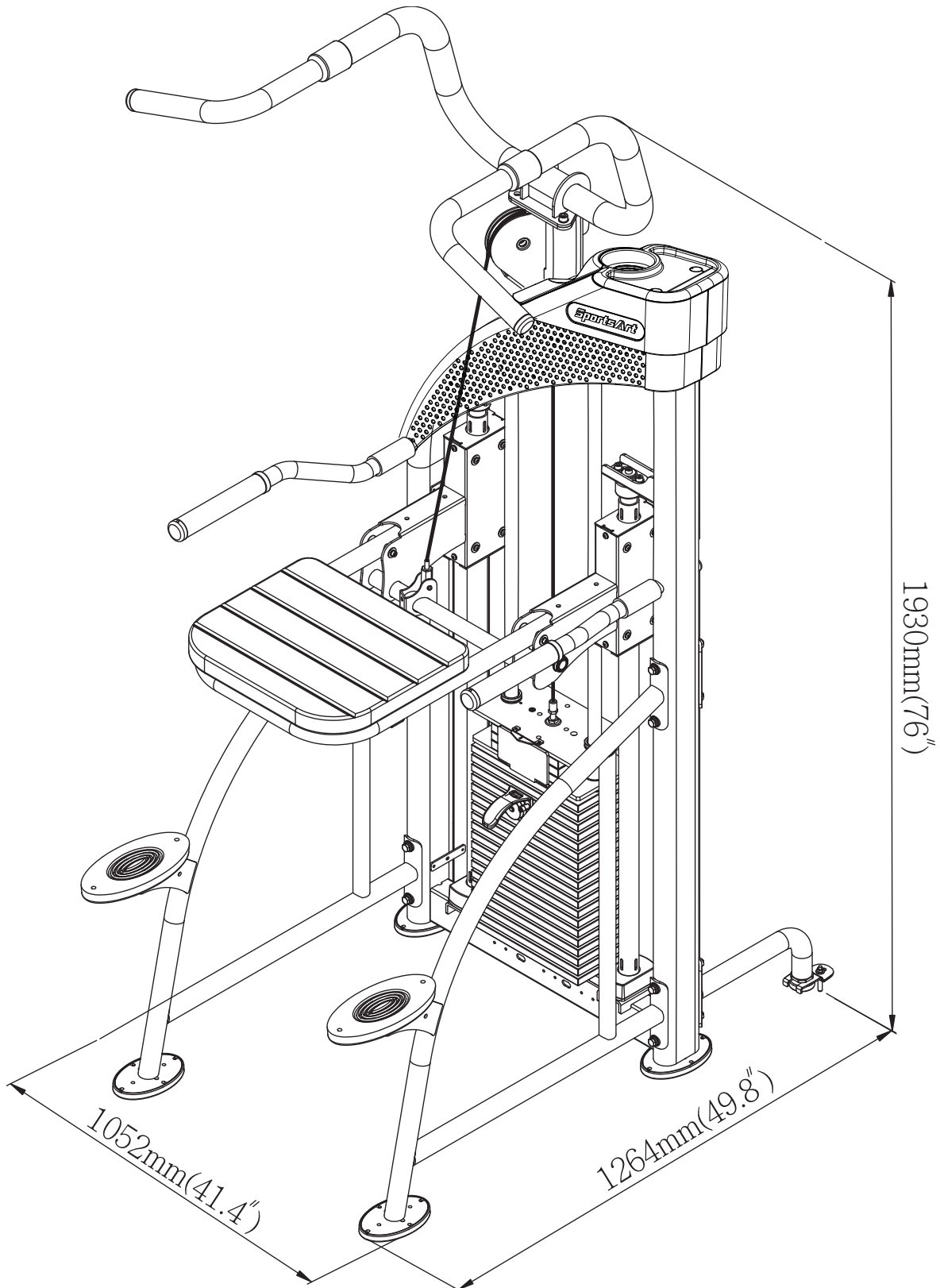

2. SAFETY PRECAUTIONS

This product was designed and built for optimum safety. However certain precautions apply during the use of this product. Please note the following safety precautions:

- Please read the entire manual before assembly and operation. Make sure the product is installed and operated as instructed in this manual.
- Assemble and operate the product on a solid, level surface. Do not use outdoors or near water, including pools and saunas.
- Check the product before every use. Make sure all parts are assembled, and all fasteners are tightened. Do not use the product if it is disassembled in any way.
- Wear proper workout clothing. Do not wear loose clothing. Do not wear shoes with leather soles or high heels. Tie all long hair back. Do not go barefoot on this product.
- Keep away from moving parts. Moving parts may or may not stop immediately if an object becomes caught or impedes normal motion.
- Use this product only for its intended purpose as described in this manual.
- Be careful when mounting and dismounting the unit.
- Never operate this product if it has been damaged in any way. If it is not working properly, or has been dropped or damaged, contact a service technician for repairs.
- Do not use accessories or parts that are not specifically recommended by the manufacturer (SportsArt). Such parts might cause injuries or cause the unit to fail and void the warranty. We are not responsible for any safety issue that arises due to the misuse of accessories or parts. At the same time, we will terminate the warranty terms of this equipment.
- This product is not intended for use by persons (including children 14 or younger) with reduced physical, sensory, or mental capabilities, or by people who are otherwise deficient in product knowledge or experience. If such people use this product, they should be given training and be supervised at all times by someone responsible for their safety.
- Contact your SportsArt representatives on all materials damaged in shipment. (Note: Shipping damages are the responsibility of the carrier.)
- Unpack and verify contents of boxes according to the list of parts to check if any parts are missing.
- Children 14 or younger should be supervised to ensure that they do not play on or near the product.
- The user weight limit for this product is 227 kg, 500 lb.
- Maintenance and repair must be performed by trained service personnel only. Improper maintenance would not only damage the machine, but may also present a danger to the exerciser.
- Over exercise may result in serious injury or death
- Warning that any of the adjustment devices that could interfere with the user's movement should not be left projecting.

CAUTION: If you feel any pain or any abnormal sensations, **STOP YOUR WORKOUT** and consult your physician immediately. Work within your recommended exercise level. **DO NOT** work to exhaustion. Before beginning any exercise program, you should consult with your doctor. It is recommended that you undergo a complete physical examination.

*NOTE: Each machine provides a different resistance ratio of weight stack.

3. LIST OF PARTS

Box A

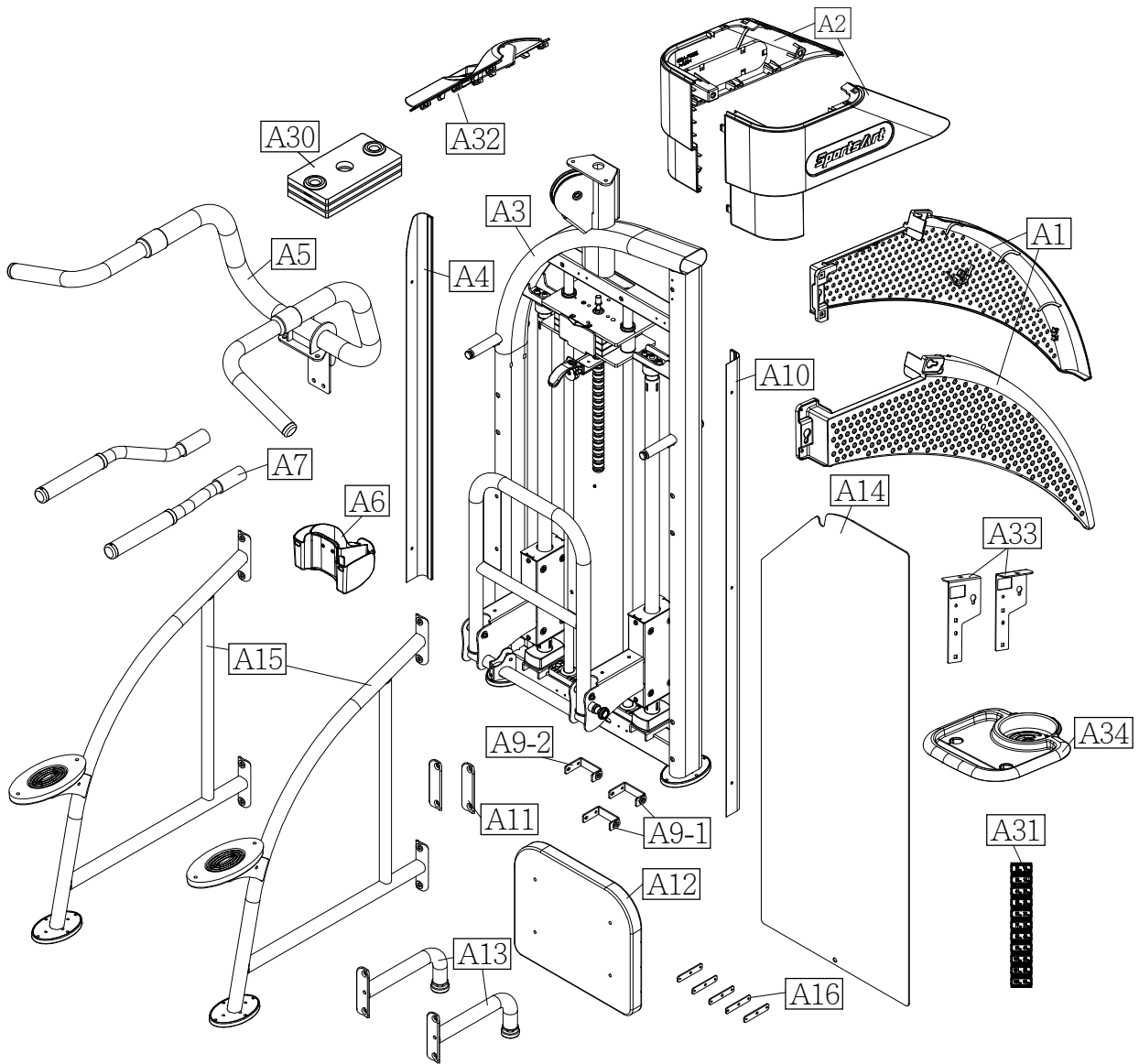

Box B

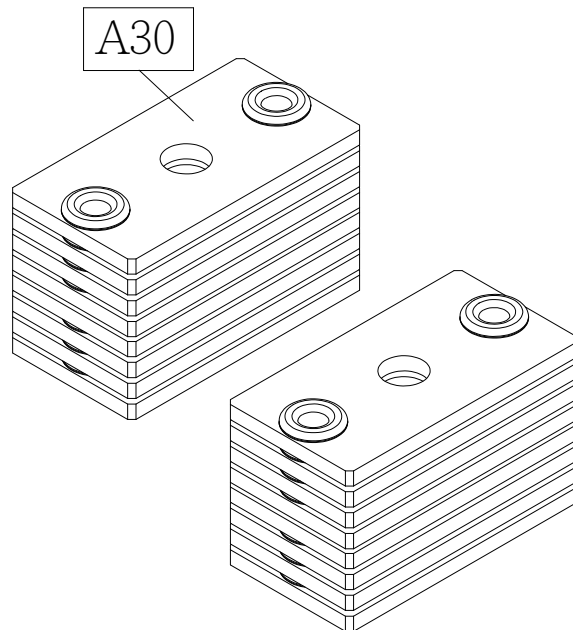

Box A - Main Frame Components					
No.	Name	Qty.	No.	Name	Qty.
A1	Left/right perforated boards	1	A11	Ø50 Connector	2
A2	Left/right side cover	1	A12	Knee cushion	1
A3	Main frame	1	A13	Rear support	2
A4	Cover support plate B-2	1	A14	Rear cover	1
A5	Top handle frame	1	A15	Front support	2
A6	Storage tray	1	A16	Bracket	5
A7	Right and left handles	2	A30	5kg/11lb weight plate	3
A8	Connector	1	A31	Weight plate sticker	1
A9-1	Anchor bracket of shroud (square hole)	2	A32	B Front cover B	1
A9-2	Anchor bracket of shroud (tapped hole)	1	A33	Anchor bracket	2
A10	Cover support plate A	1	A34	Top cover	1

Box C - Weight Plates Components					
No.	Name	Qty.	No.	Name	Qty.
A30	5kg/11lb weight plate	16			

Components in the Hardware Kit				
No.	Name	Qty.	Specification	Notes
12	Hex head screw	8	M10*P1.5*L130	
	Spring washer	8	M10	
	Washer	16	D16*d10.2*t1.0	
	Nylon hex lock nut	8	M10	
14	Screw socket	1 batch	SGN-07	
15	Mushroom top inner hex screw	12	M6*P1.0*L12	
16	Mushroom top Phillips screw	10	M5*L15	
17	Mushroom top Phillips screw	5	M5*P0.8*L8	
18	Round head inner hex screw	1	M6*P1.0*L12	
	Bushing	1	D19*7.8	
19	Flat washer	2	D27*d6.3*t3.0	
	Mushroom top inner hex screw	2	M5*L20	
20	Floor fixing bracket	1		
21	U bracket	1		
	L-shaped Allen wrench	1	(M5)	
	L-shaped Allen wrench	1	(M6)	

Components in the Hardware Kit			
No.	Name	Specification	Notes
	L-shaped Allen wrench	1	(M8)
	Open end wrench	2	(13*17)
	Phillips-head screw driver	1	
70	Phillips pan head sheet metal screw	6	M4*L12
71	Phillips Umbrella head sheet metal screws	2	M4*L14
72	Round screw cap	2	
73	Fastener	1 batch	
	Cap nut	1 batch	

Components on the Product			
No.	Name	Specification	Notes
22	Upper stack carriage set		
23	Hex bolt	M8*P1.25*L65	
	Washer	D17*d8.3*t2	
	PU tube	D12*d8*L51	
	Nylon hex lock nut	M8	
24	Guide rod		
25	Mushroom top inner hex screw	M6*P1.0*L12	
26	Mushroom top Phillips screw	M5*0.8*L8	
27	Mushroom top inner hex screw	M8*P1.25*L25	
	Spring washer	M8	
	Flat washer	D22*d8.2*t2	
28	Round head inner hex screw	M6*L8	
	Spring washer	M6*t1.5	
29	Round head inner hex screw	M10*P1.5*L15	
	Washer	D16*d10.2*t1.0	
	Spring washer	M10	
30	Round head inner hex screw	M10*L20	
	Spring washer	M10	
	Washer	D26*d10.3*t3.0	
65	Reinforcement plate		
	Anchor bracket		
	Umbrella hex screw	M6*P1.0*L20	
	Plastic cover		
66	Umbrella hex screw	M6*P1.0*L12	

4. ASSEMBLE THE PRODUCT

Follow instructions below to assemble this product. Note that in this manual the words “left” and “right” are used to refer to the product and its parts. As such, these designations correspond to the “left” and “right” sides of a person in position to exercise on this product. Also, for brevity, the word “screws” or “nuts” is used where washers and other hardware may be involved.

STEP 1 Cover Support, Connector & Front Support Installation

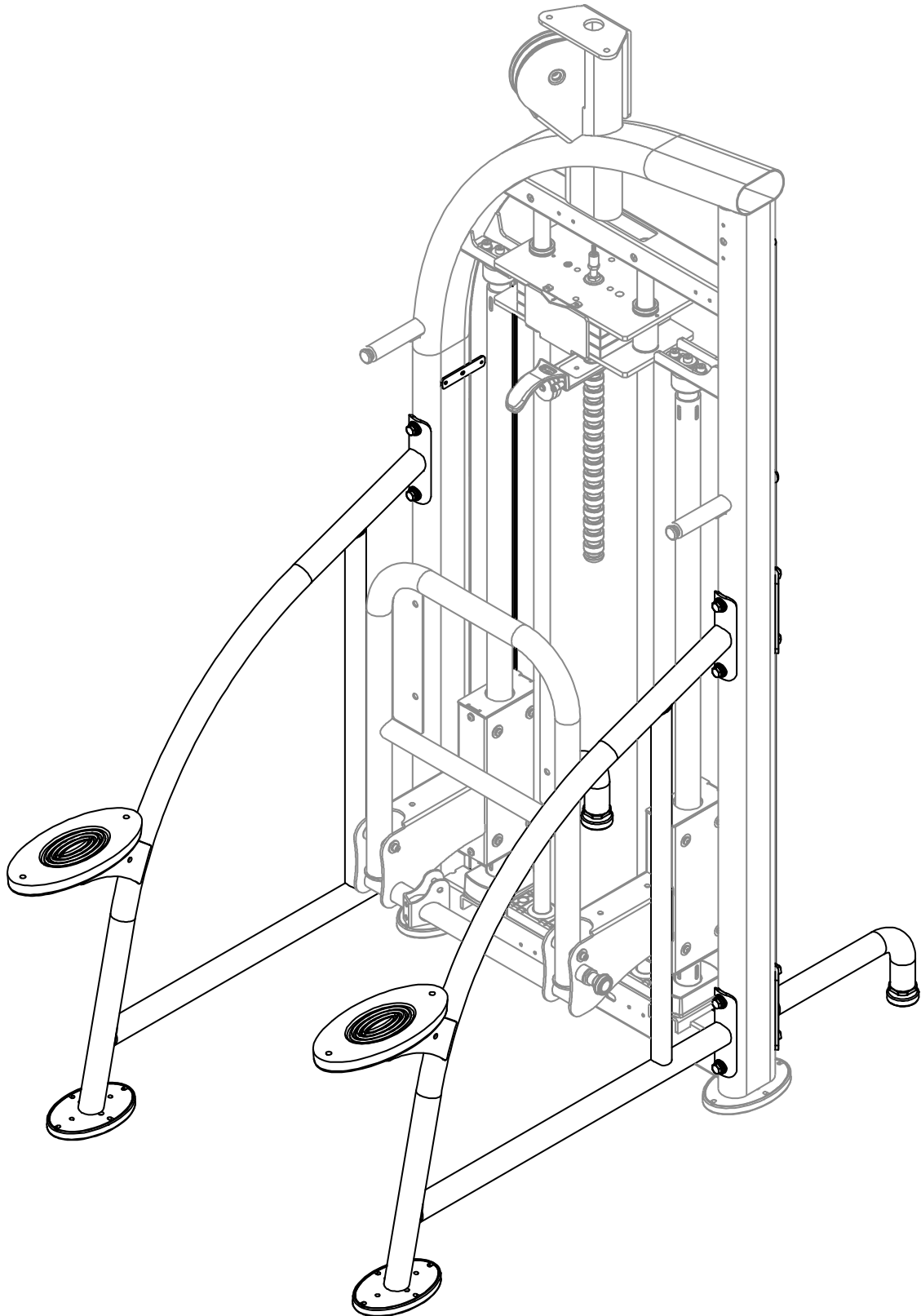

STEP 1 Cover Support, Connector & Front Support Installation (CONT.)

- * Do NOT cut the zip tie of seat frame when you lift the main frame up.
- * We recommend you to assemble the machine with at least two people.
- (a) Insert the screw sockets (14) into place in the main frame (A3) as shown, and then use screws (16) to secure the brackets (A16) in place. *(Note: The prominent side of bracket (A16) must be secured in back of main frame.)*
- (b) Secure the plate slots (A10) to the straight frame of the weight stack tower (A3) with the screws (17) and then cover the cap nuts (60). The plate slots (A4) are secured of the curved frame, respectively

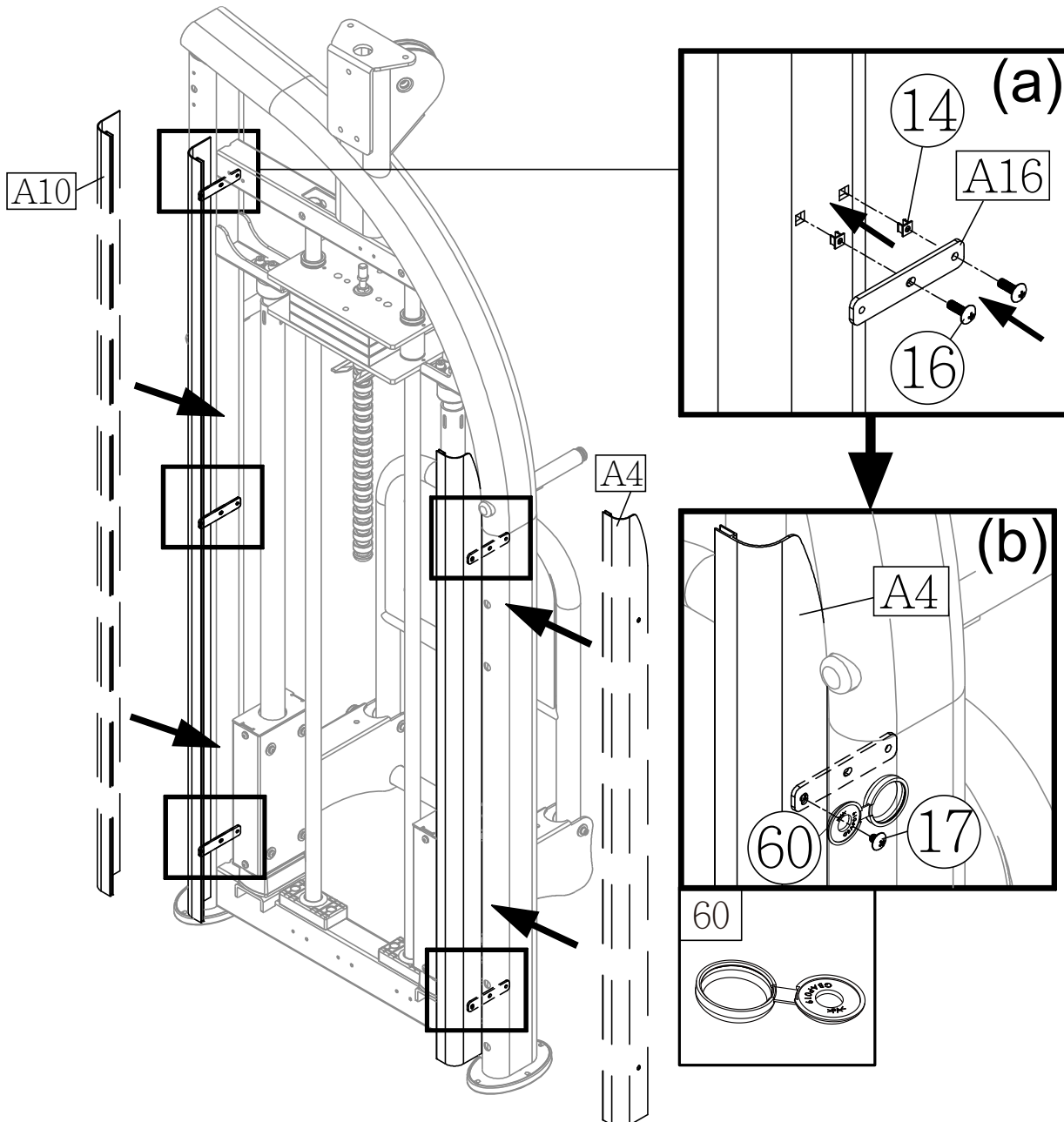

STEP 1 Cover Support, Connector & Front Support Installation (CONT.)

(c) Use the connector (A11) to connect the front support (A15) and secure with screws (12) at area A as shown and then secure the rear support (A13) to the front support (A15) with screws (12) at area B as shown.

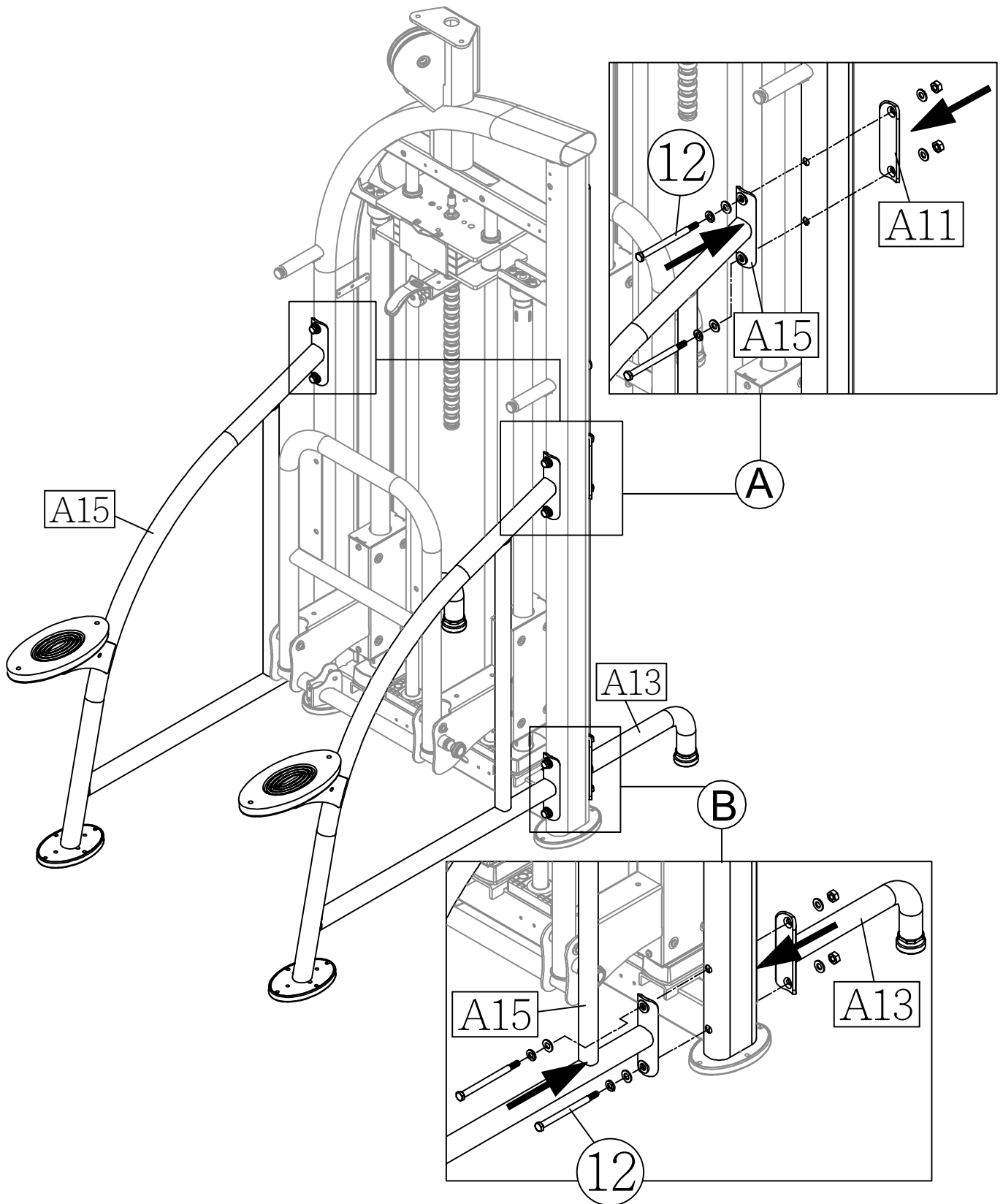

STEP 2 Weight Stack Installation

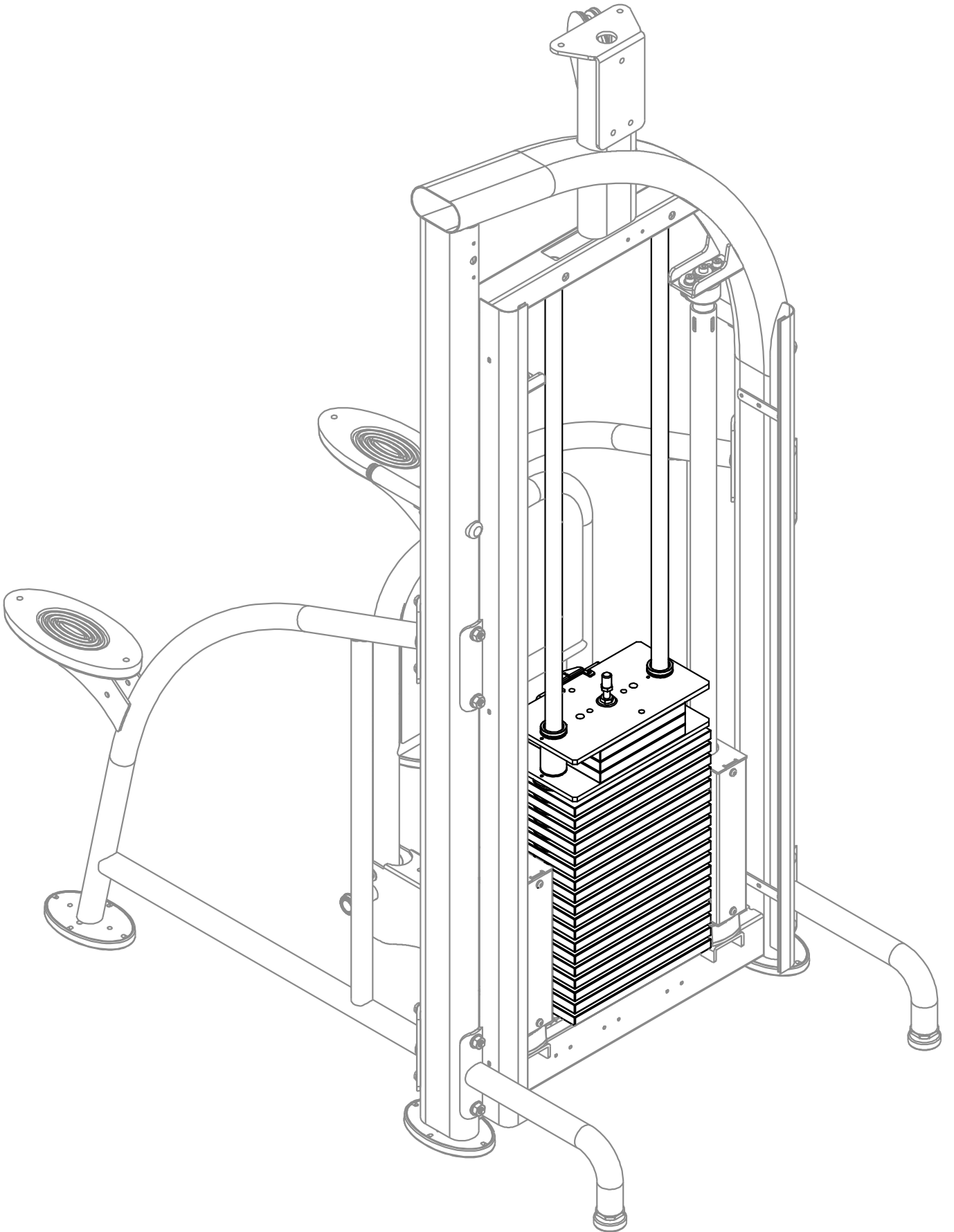

STEP 2 Weight Stack Installation (CONT.)

- (a) Hold the upper stack carriage set (22), and then cut the zip tie. Gently lower the upper stack carriage set (22) into place as shown.
- (b) Remove screws (23). Set the guide rod (24) downward into place as shown.
- (c) Tilt the guide rod (24) backward and then lift the upper stack carriage set (22) off the guide rods as shown. Carefully set the upper stack carriage set (22) aside and Do NOT give a strong pull at the cable.

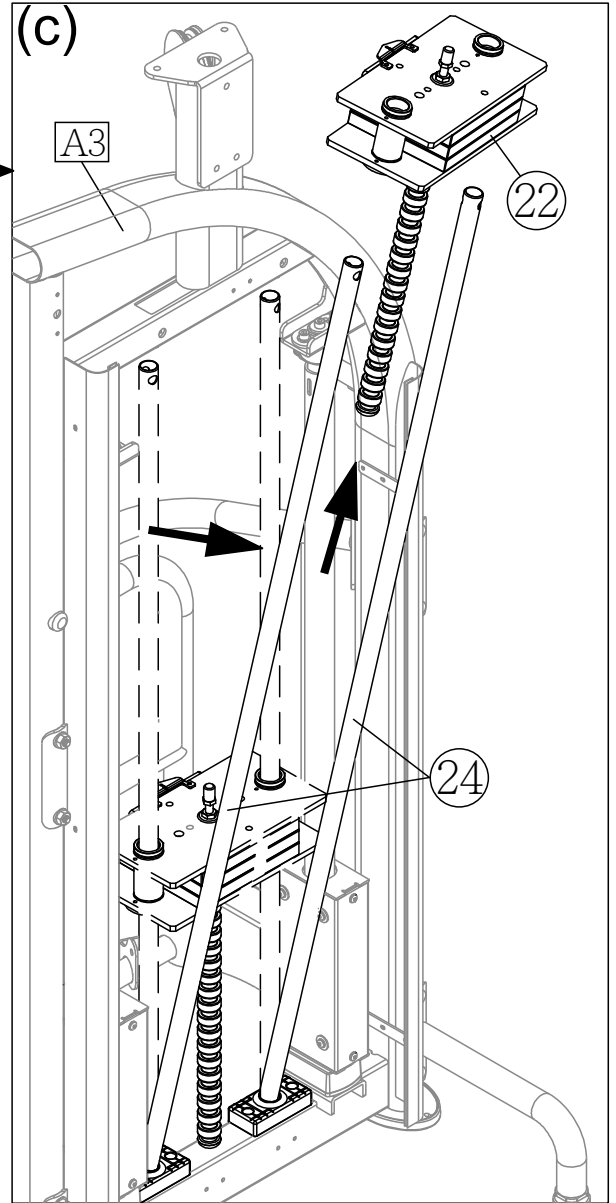
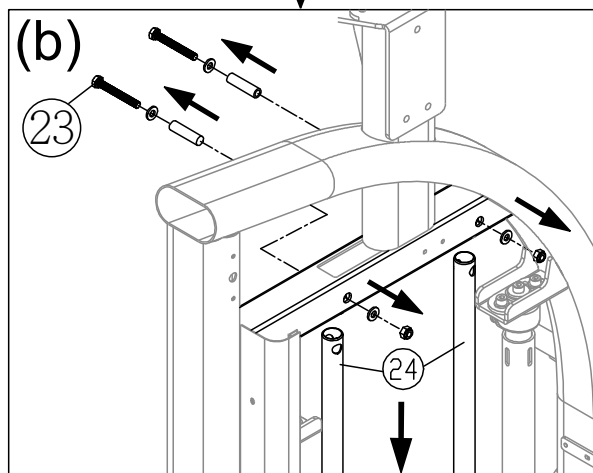
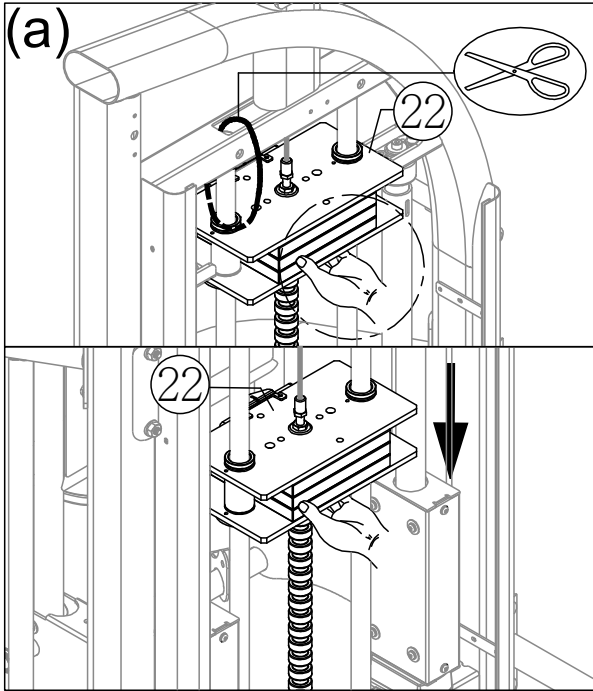

STEP 2 Weight Stack Installation (CONT.)

(d) Insert and lower the (5 kg/11lb) weight plates (A30) into place on the guide rods (24) one at a time. Once complete, slide down the upper stack carriage set (22) on top of the weight stack. (Note: The convex side of weight plate should face up and the stack fork (A7) points toward the front.)

*Install the cap nuts on the screws.

(e) Tilt the guide rods (24) back into place and then lift them up to their mounting position, and then secure the assembly with screws (23).

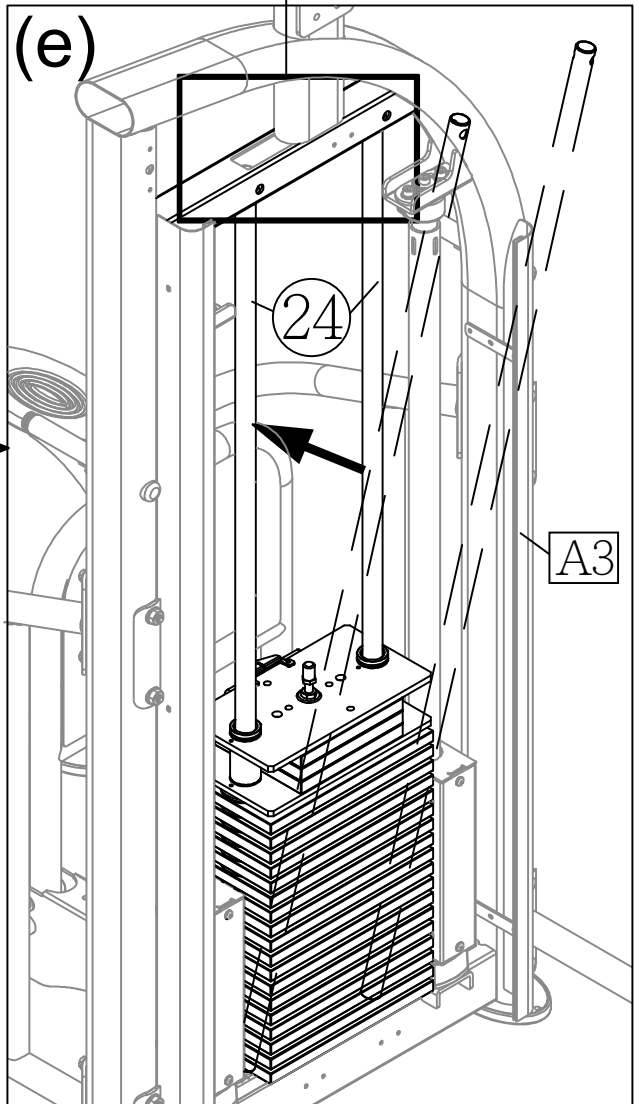
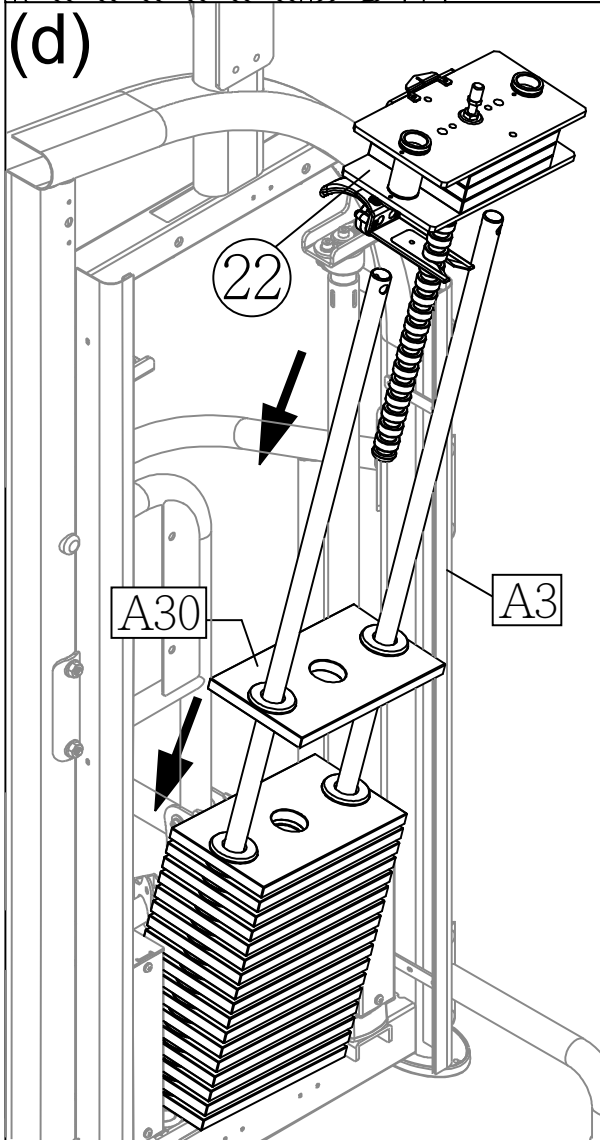
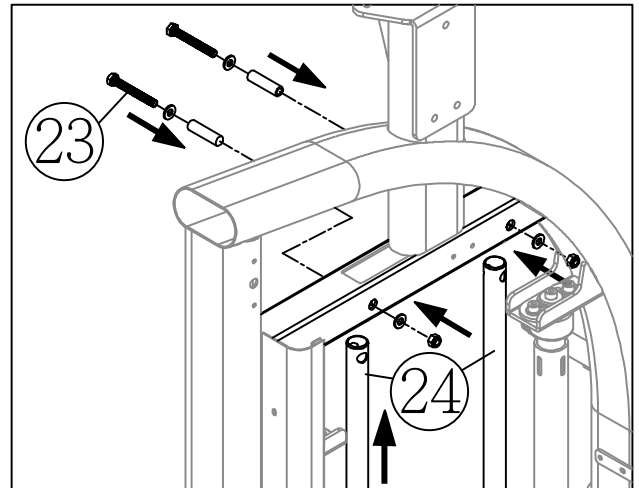
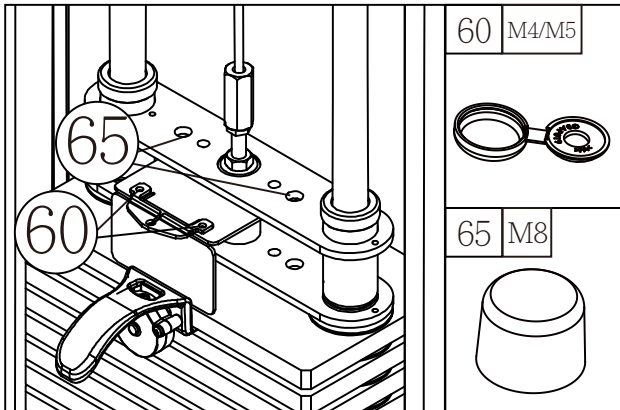

STEP 3 Cable Adjustment

Hold the crossbar of the seat, and then cut the zip tie. Let the seat rise slowly up into place.

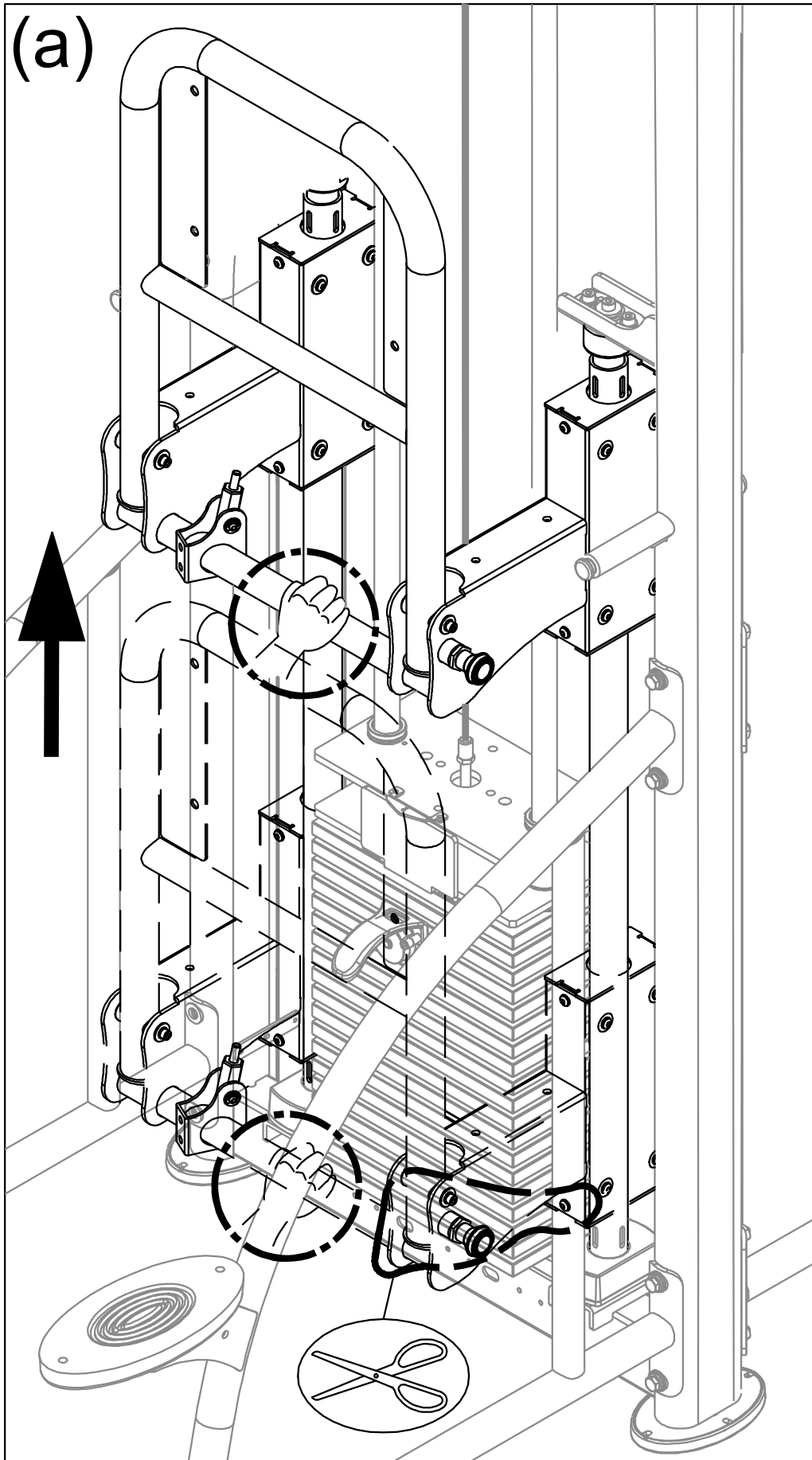

STEP 3 Cable Adjustment (CONT.)

Check the cable at C. It should not be larger than the dimension shown in the figure, or there will be the safety issue.

To adjust the cable, first insert the (Z) rod and loosen the (Y) nut, and then adjust the (X) nut. If the cable is too long, adjust the (X) nut downward. If too short, adjust the (X) nut upward. After adjusting the (X) nut, tighten the (Y) nut against the weight stack to secure this position.

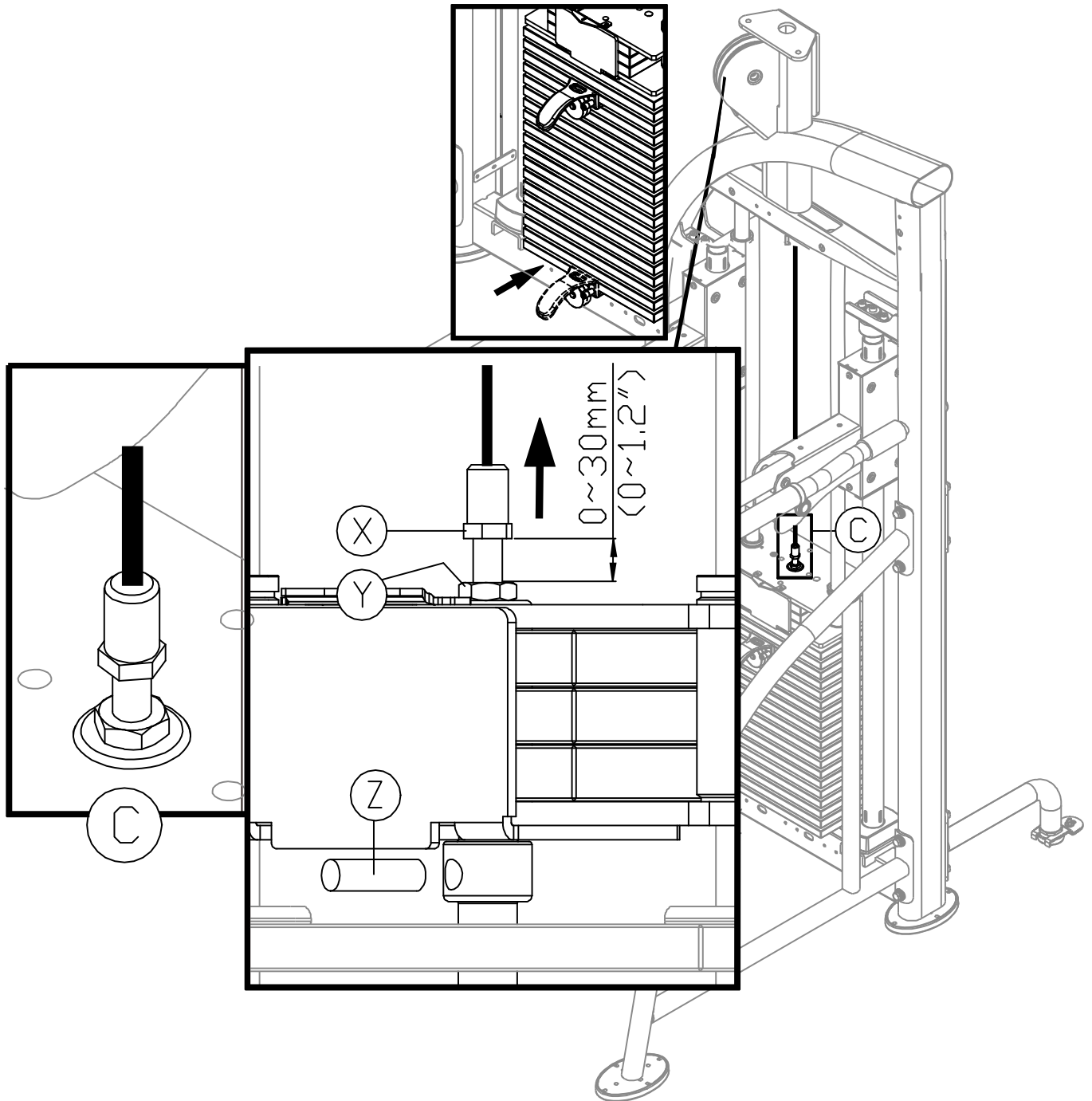

STEP 4 Apply the Weight Stack Sticker

Note: Before applying weight plate stickers, please wipe the area clean, and clean your hands before proceeding to the next step.

- (a) Align and tape the cardboard to the upper left corner of the weight plate (A40).
- (b) Peel off the top half of the weight plate sticker (A41) backing. Leave the clear outside margin in place on the sticker. Don't peel off the margin.
- (c) Press the numbered part of the sticker in place while you peel off the clear margin of the sticker.
- (d) Peel off the clear margin of the sticker.
- (e) Follow steps (b) ~ (d) to apply another weight plate sticker to the lower part of the weight stack.
When the stickers are in place, peel off the cardboard. Press the sticker in place to ensure good contact on the weight plate.

*If there are additional optional weight plates, use the optional weight plate stickers.

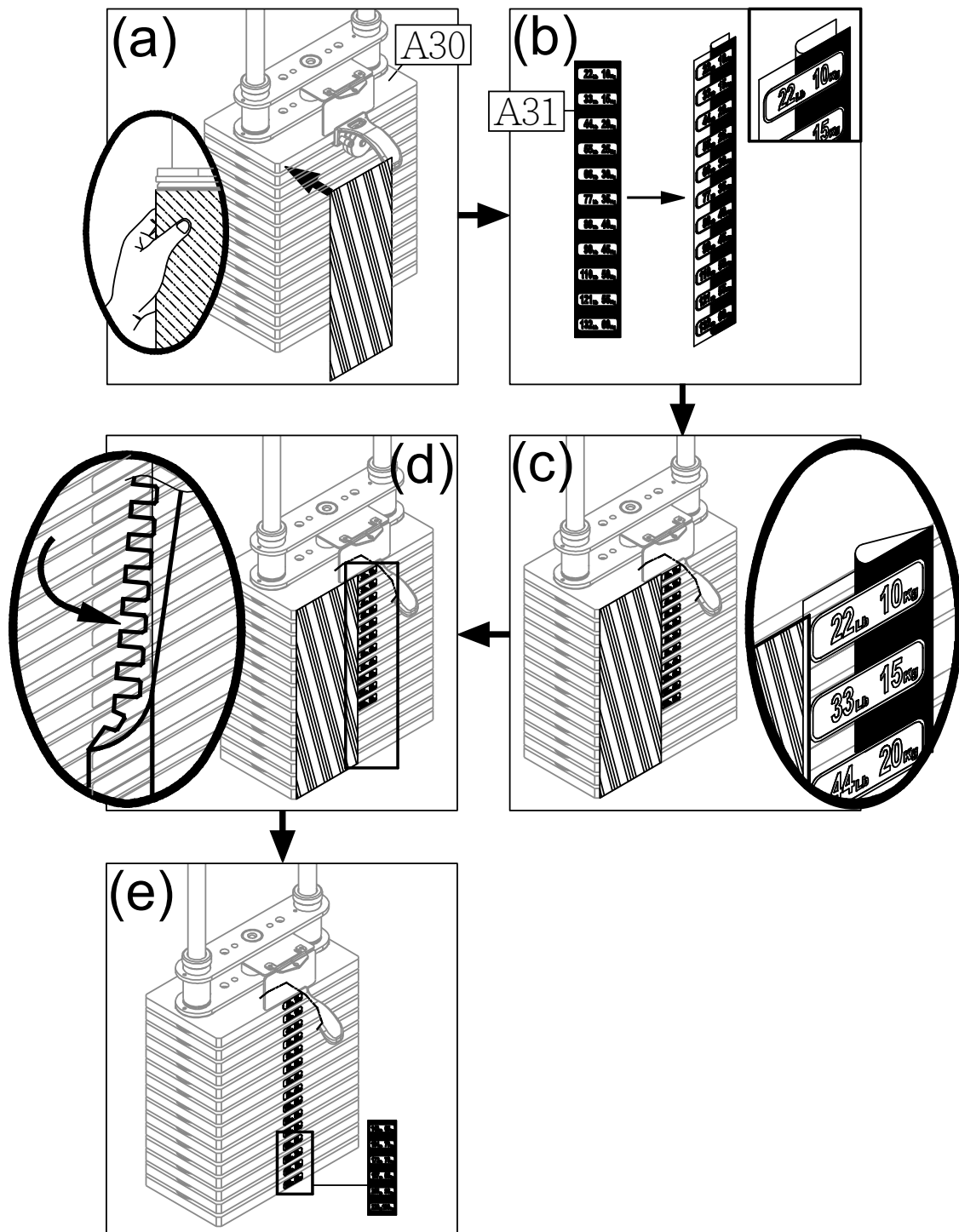

STEP 5 Seat Bottom Installation

- (a) Loosen and remove screws (27) from the knee cushion (A12).
- (b) Secure the knee cushion (A12) to the seat frame with screws (27) as shown.

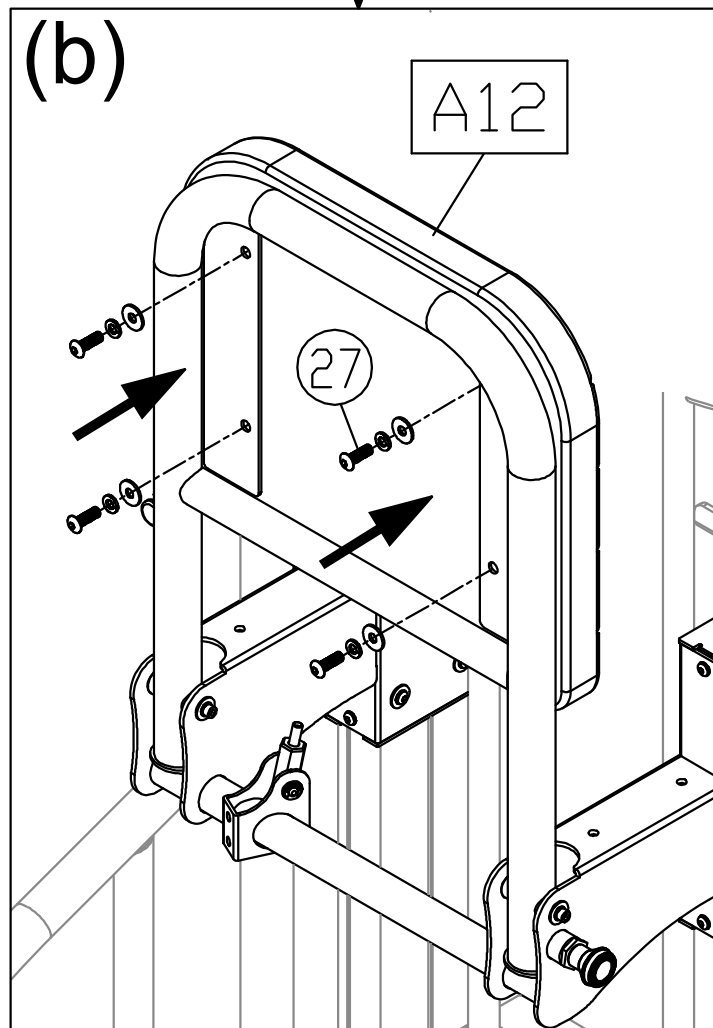
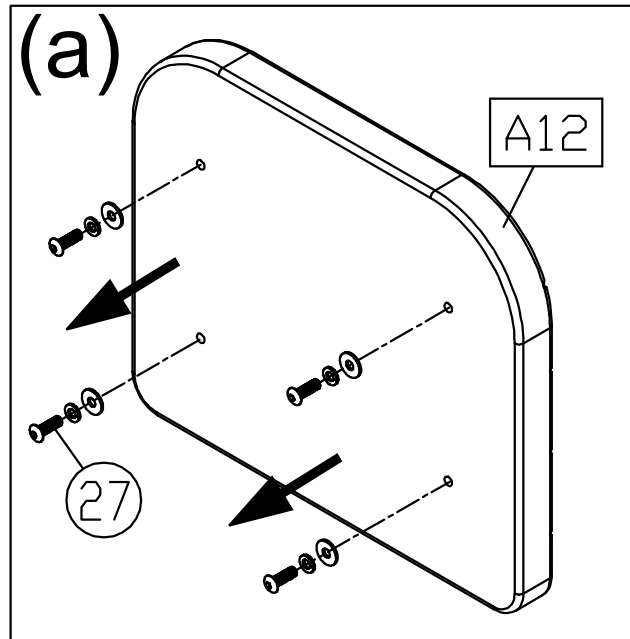

STEP 6 Rear Cover Installation

- (a) Loosen and remove screws (25) from the main frame (A3).
- (b) Install the square snap bushings (14) to the anchor brackets of shroud (square hole) (A9-1). Secure the anchor brackets of shroud (square hole) (A9-1) with the square snap bushings (14) to the front and back of the upper crossmember assembly of weight stack tower with screws (25). Secure the anchor brackets of shroud (tapped hole) (A9-2) to the front and back of the lower crossmember assembly of weight stack tower with screws (25).

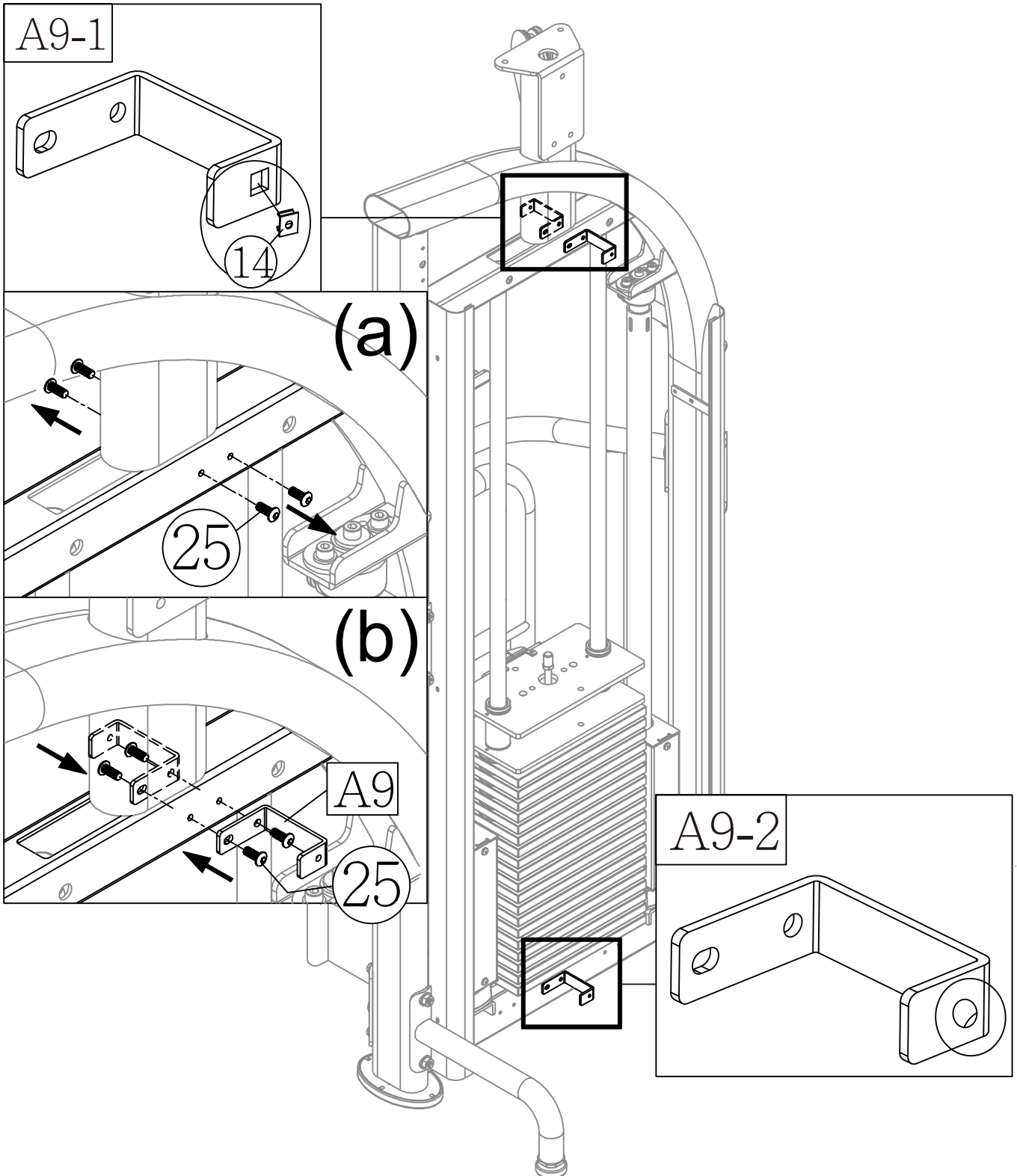

STEP 6 Rear Cover Installation (CONT.)

- (c) Slide the rear cover (A14) from the top down into the cover support plates' grooves (A4) (A10).
- (d) Secure the lower shroud with the screw (65).

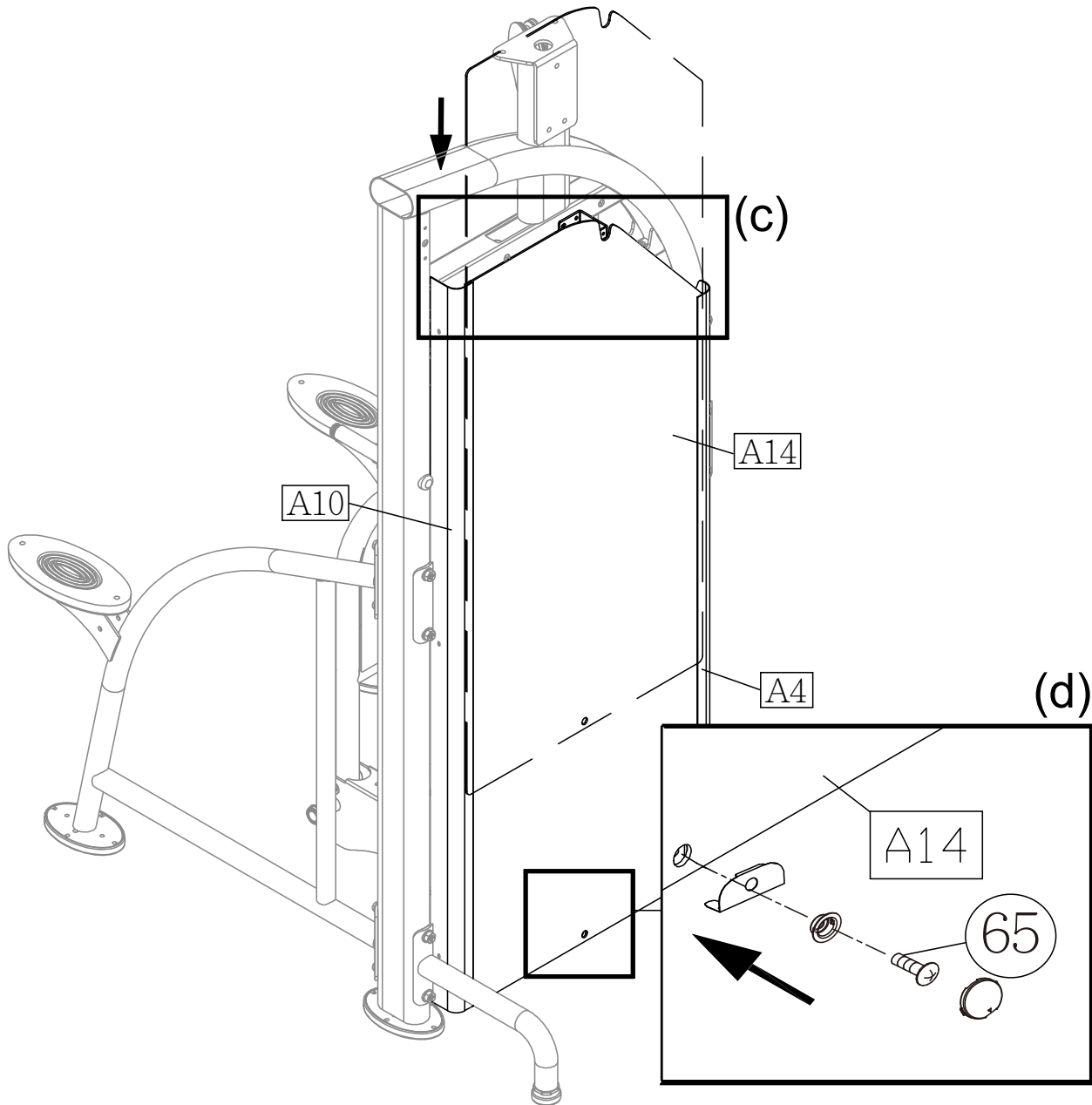

STEP 7 Install Plastic Cover

- (a) Install the square snap bushing (14) and fastener (73) to the anchor bracket (A33) and remove the screws (66) on the main frame. Secure the anchor bracket (A33) to the main frame with the screws (66).
- (b) Secure the left/right perforated boards (A1) to the main frame with the screws (70).
- (c) Install the front cover B (A32) to the main frame first. Assemble the left/right side cover (A2) and the front cover B (A32) together and then embed the top cover (A34), which is the water bottle holder, at an oblique angle. Loosen and remove screws (26) from the left/right perforated boards (A1), and then use screws (26) to secure the connector (A8) from down on the inner bracket of the top covers.
- (d) Secure the top cover (A34) to the main frame with the screws (71) and then install the round screw caps (72).

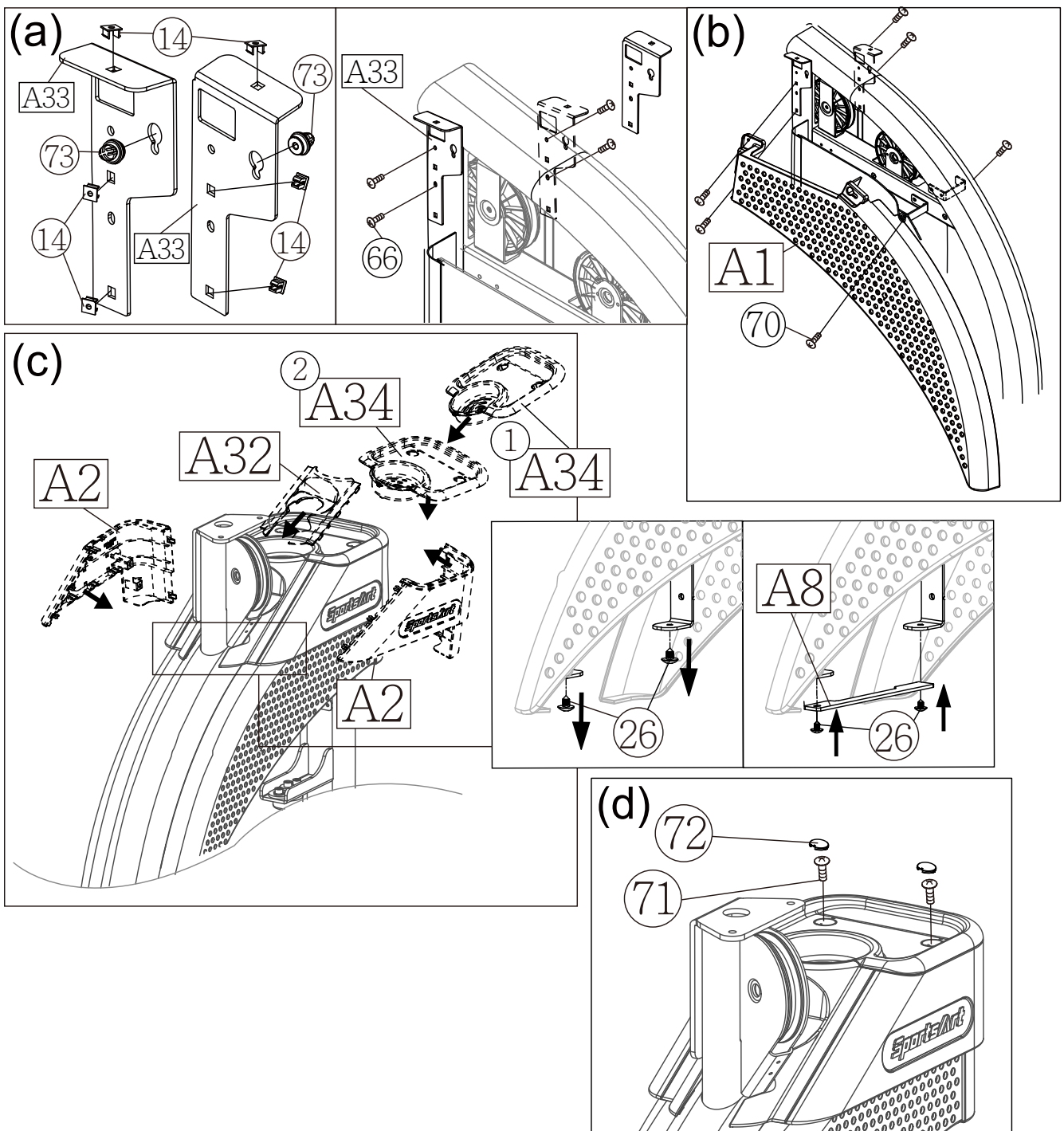

STEP 8 Handles Installation

- (a) Loosen and remove screws (28) from the right and left handles (A7).
- (b) Insert the right and left handles (A7) onto their mount stems on the main frame and secure them in place with screws (28) as shown.
- (c) Loosen and remove screws (29) (30) from the main frame (A3).
- (d) Put the top handle frame (A5) on the main frame (A3), and then align holes and secure the assembly with screws (29) (30).

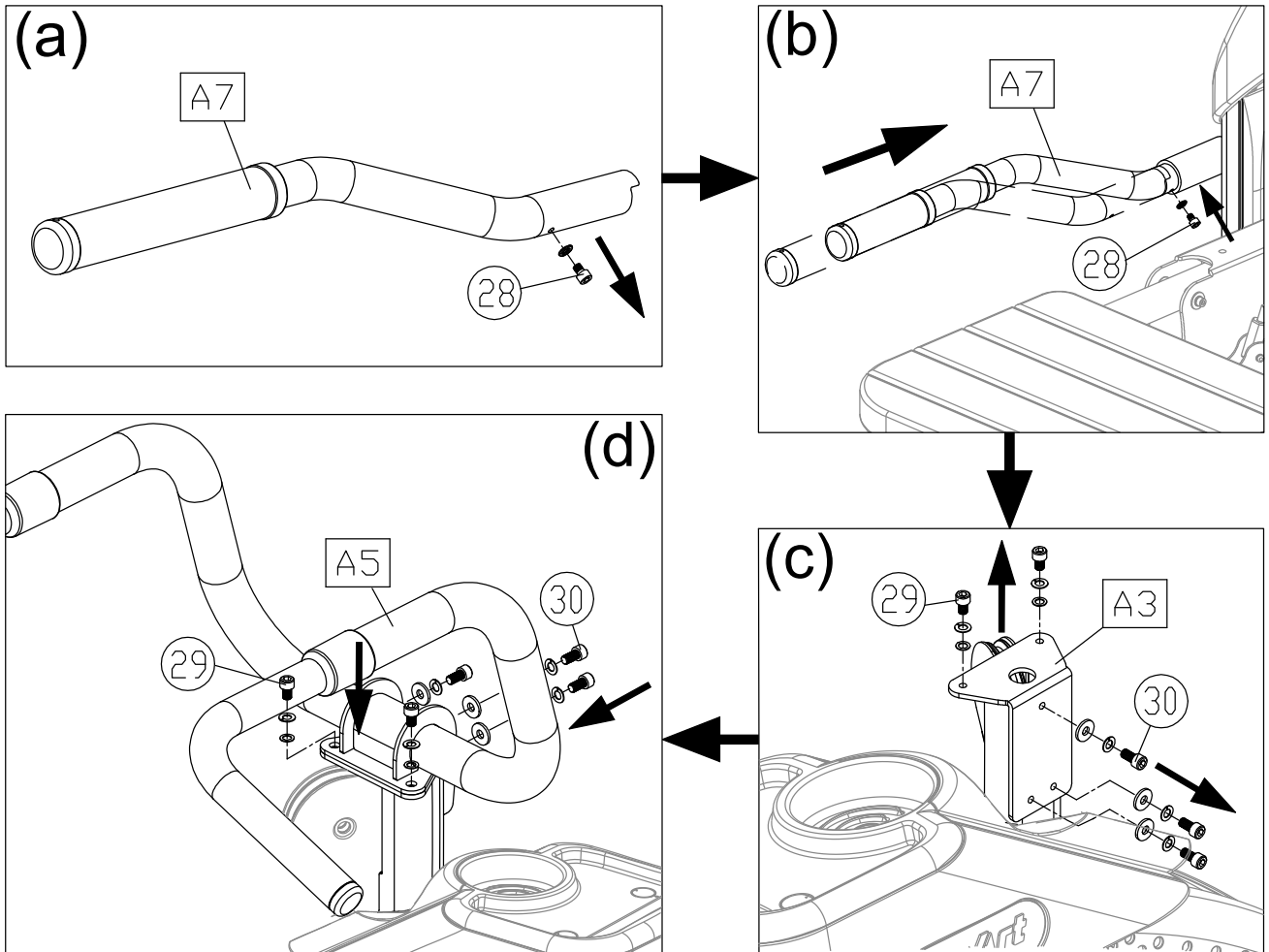

STEP 9 Storage Tray Installation

(a) Align the storage tray (A6) to the holes in the main frame, and then secure the storage tray with screws (19) as shown.

*Install the cap nuts on the screws.

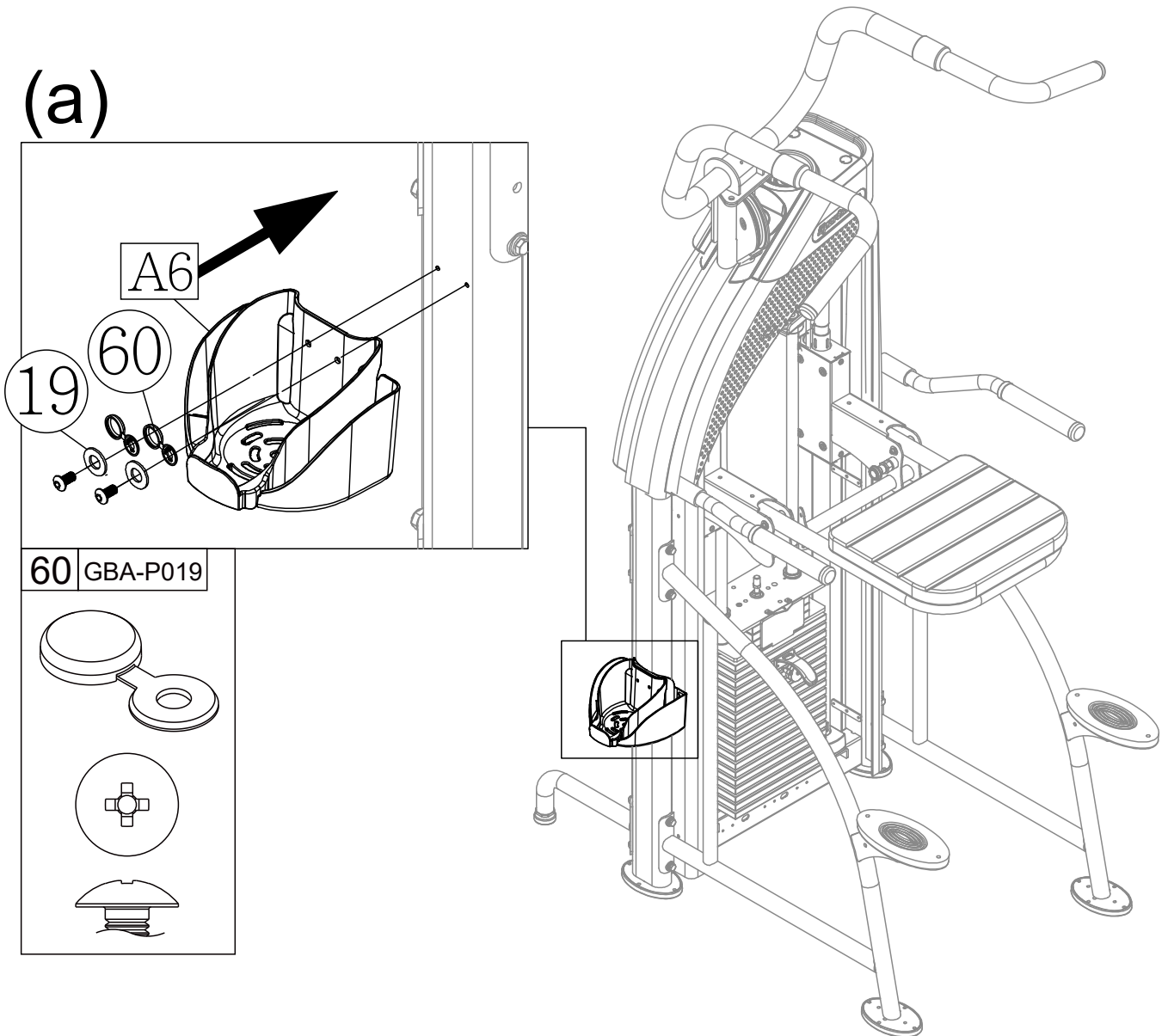

STEP 10 Install Cap Nut

Install the cap nuts to the corresponding positions according to the following numbers.

*The cap nuts in the following table are for reference only. The provided cap nuts will depend upon the needs of the different devices.

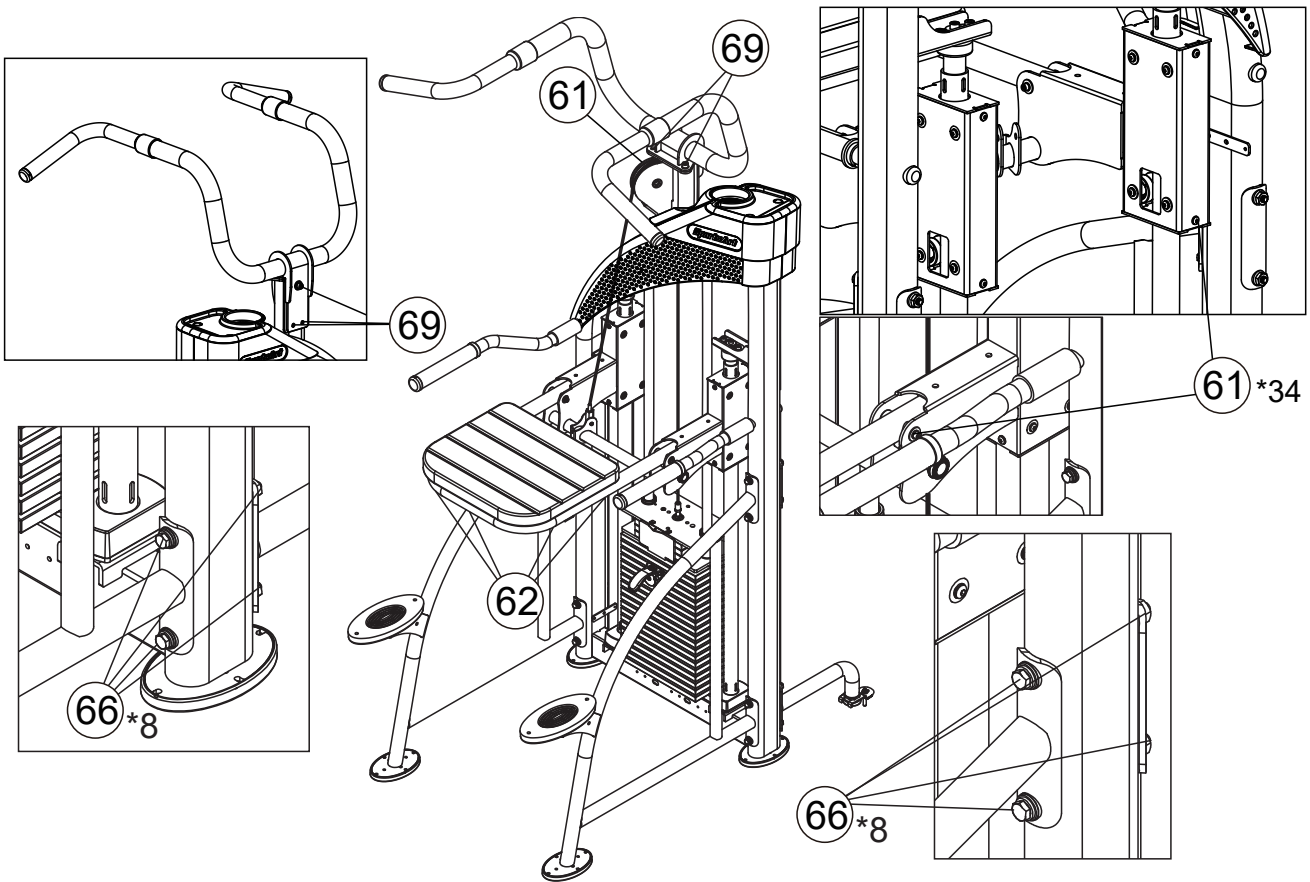

60 GBA-P019	61 GBA-P024	62 GBA-P014	63 GFA-P136	64 GBA-P018
65 GBA-P017	66 GBA-P016	67 TAO-P096A	68 GFA-P137	69 GFA-P138

STEP 11 Secure the Product

Secure the floor fixing bracket on the floor with the floor fixing bolt, nut and washer as shown to make sure the machine is stable on the floor.

(Note: The screw hole of floor fixing bracket is $\varnothing 9\text{mm}$, please make sure using the suitable floor fixing bolt and drilling the proper hole on the floor.)

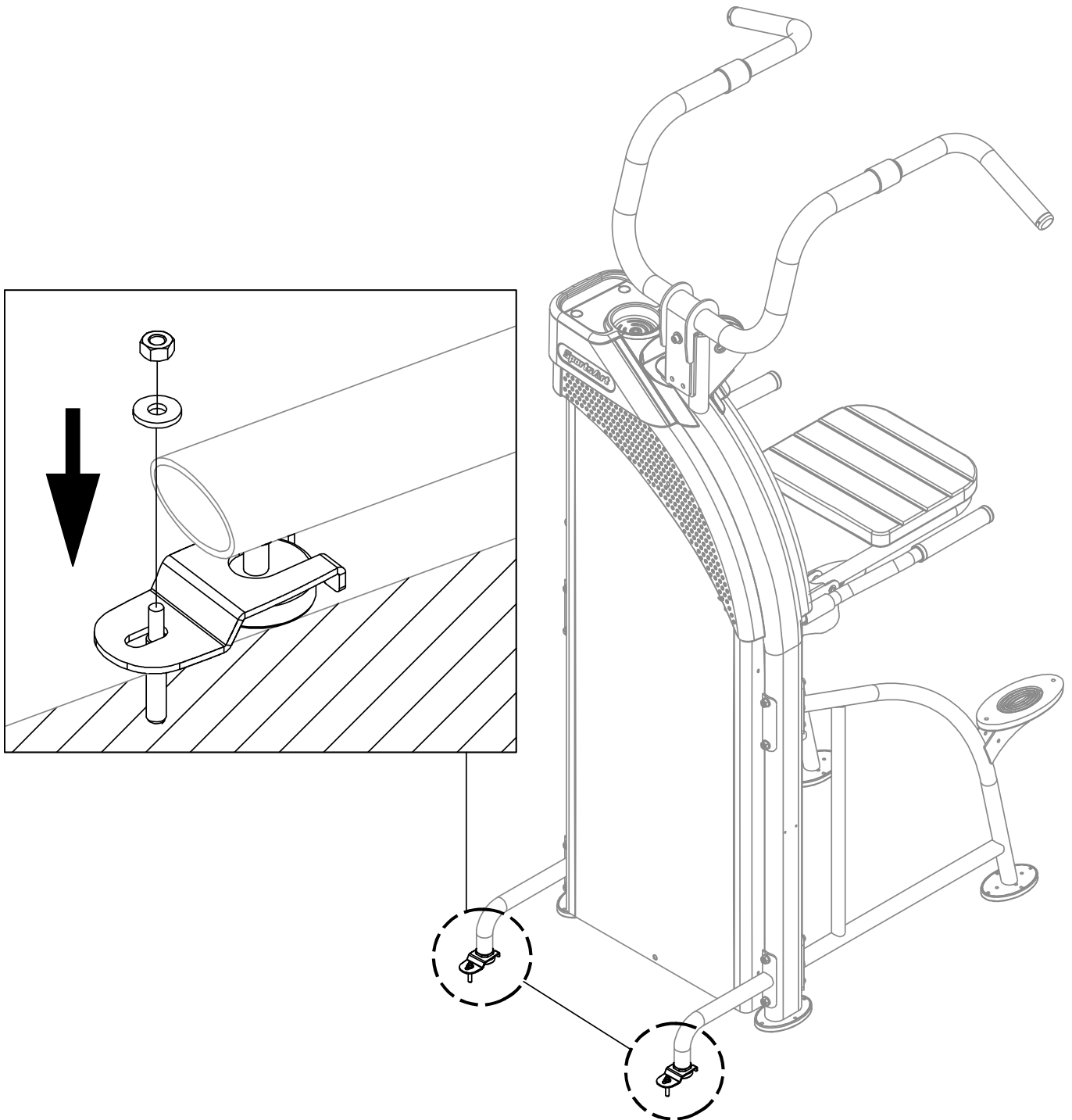

STEP 12 Stack Fork Inspections

- * Please follow operating instructions on the product sticker to test operation and confirm that the equipment is working properly.
- * Insert the stack fork to make sure that every weight plate can be engaged easily.
- * Insert the stack fork at the heaviest weight setting at which you can safely operate the equipment.
- * Exercise to lift the stack several times and then inspect the cable for proper tightness. If necessary, make adjustments according to the instructions "Cable Adjustment" of this manual.
- * Ensure that anyone who is not operator does not near the equipment when testing.

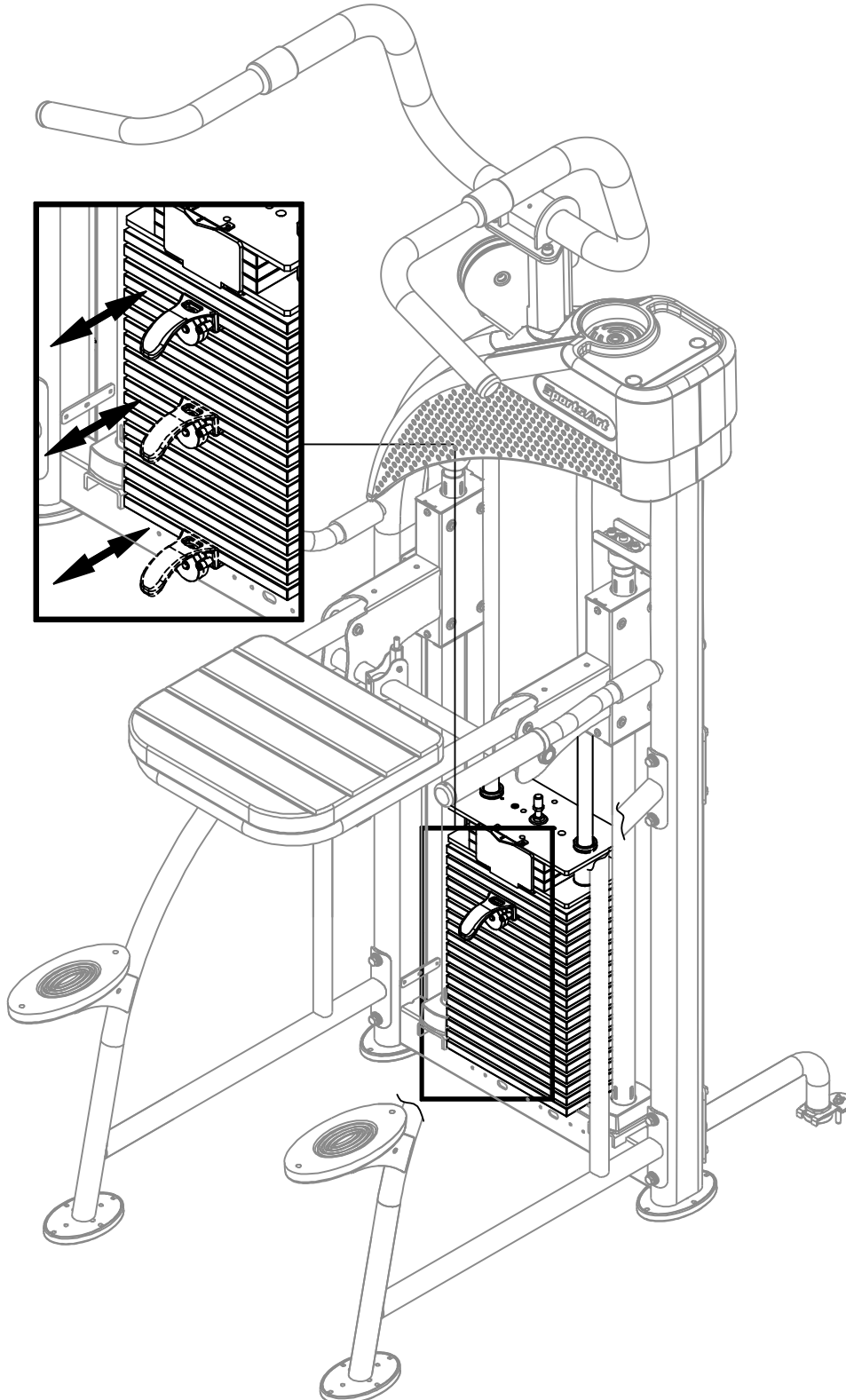

STEP 13 Unit Inspection

After completing the assembly or regular maintenance, please follow instructions (a) through (c) below to inspect the unit. If the unit is disassembled or has been damaged in any way, it might cause injuries or cause the unit to fail.

- (a) Make sure the unit is steady and on a level surface. If the unit is not steady, make adjustments according to the instructions “Level the Unit” of this manual.
- (b) Make sure all parts are assembled and all fasteners are tightened.
- (c) Please follow operating instructions to test operation and confirm that the equipment is working properly. (Please refer to “Operate the Product” of this manual.)

5. OPERATION INSTRUCTION

OPERATION Operating the Product

- (a) The top handle frame can be rotated to the right or the left for the desired width.
- (b) To change the knee cushion position, pull out knob as shown. The knee cushion can be placed up, out of the way, or down, in place to assist you.

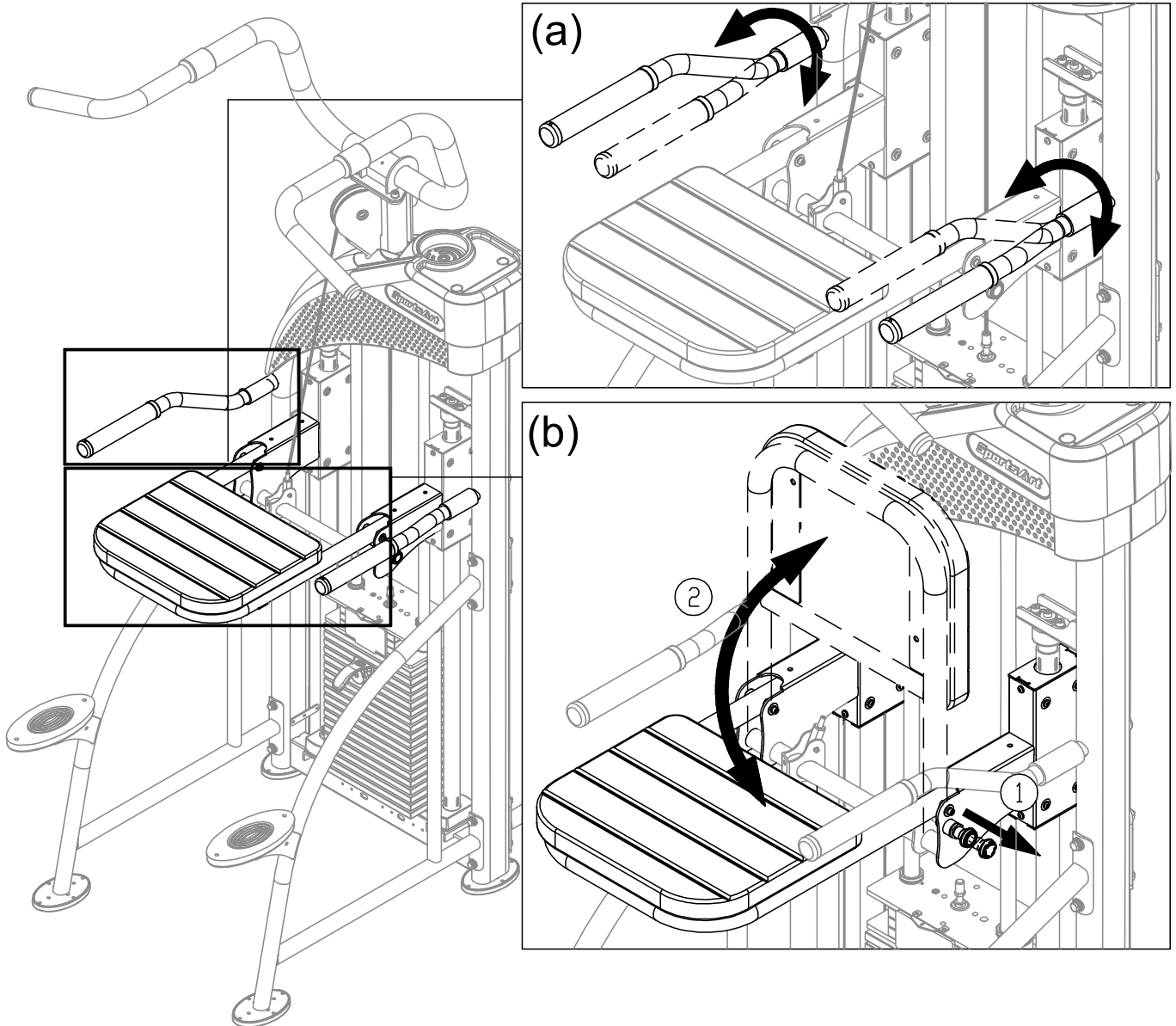

OPERATION Exercising Instructions

- (a) Select the appropriate weight plates according to your recommended exercise level.
- (b) Adjust the handles to the most comfortable position and make sure the knob is engaged to secure the position.
- (c) Perform the exercise in a controlled manner. Inhale when pushing up against resistance and exhale when returning to original position.
- * Please exercise within the range of your skill and training. DO NOT work to exhaustion.
- * All users operate this machine must be supervised under coaches instructions at all times in order for safety.

Please follow the operating instructions as below to test operation.

- (a) Please follow operating instructions on the product sticker to test operation and make sure the equipment is working properly.
- (b) Insert the stack fork at the heaviest weight setting at which you can safely operate the equipment. Exercise to lift the stack several times. Then inspect the cable for proper tightness. If necessary, make adjustments according to the instructions in this manual.

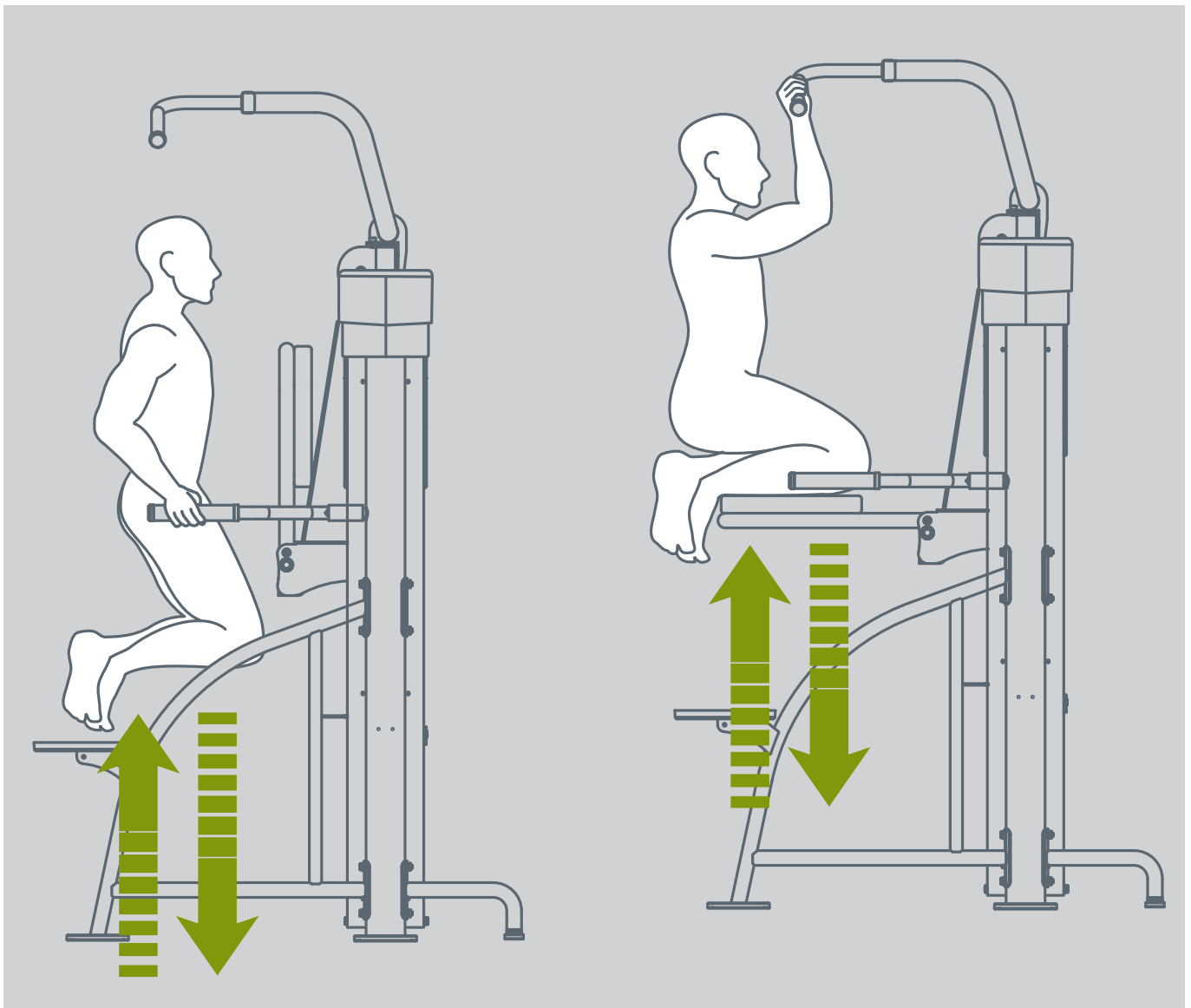

OPERATION Safety Operating Area

- (a) Safety clearance required as shown below. Do not allow people to be near this area when operating.
- (b) Noise emission under load is higher than without load.
- (c) Over exercising or improper workout position may result in serious injury.
- (d) This product is intended for exercise arms.

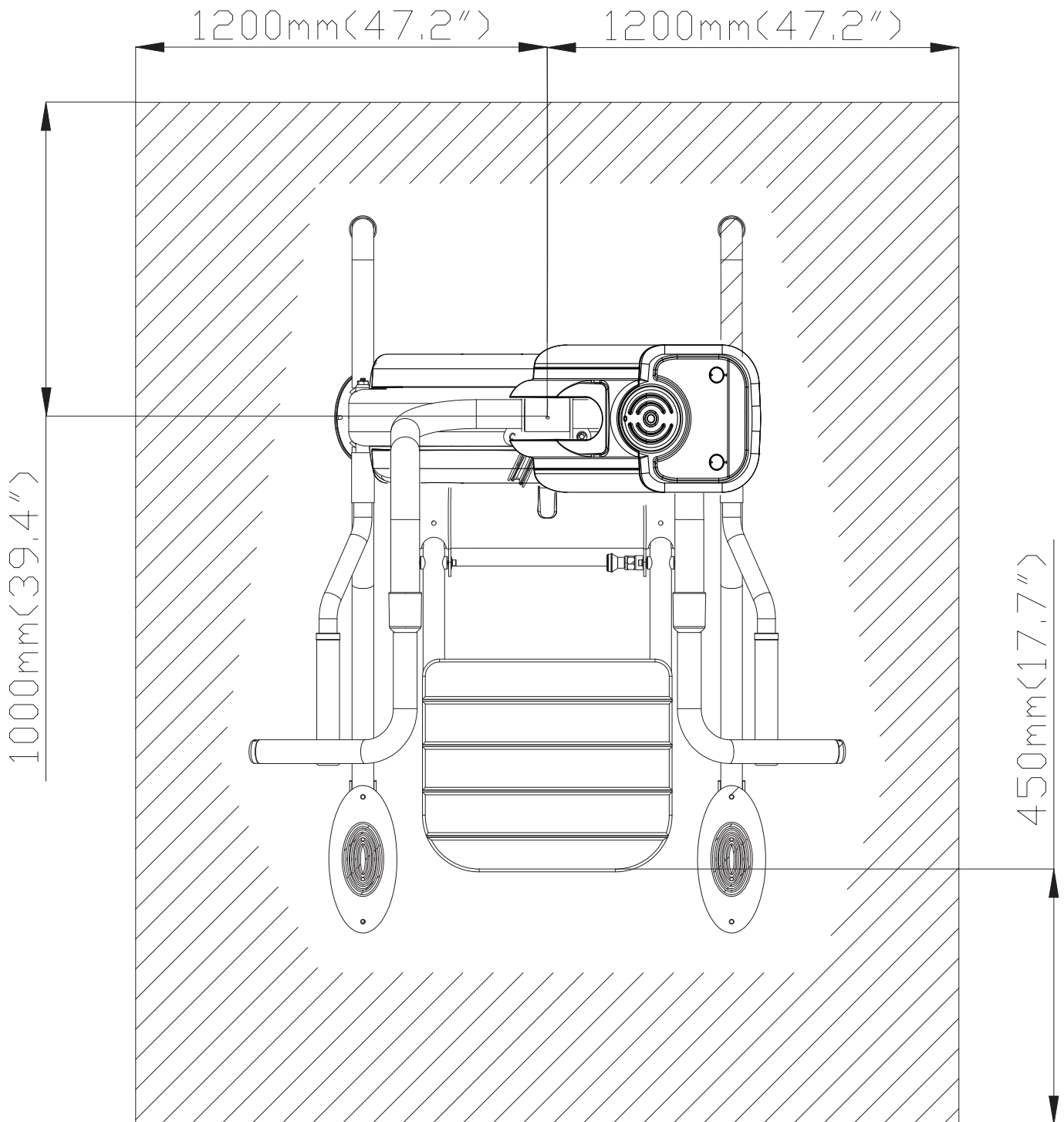

6. MAINTENANCE

This section covers maintenance topics and includes a maintenance schedule, task list, and log.

MAINTENANCE Safety Precautions

- Please follow standard safety precautions when servicing this product.
- Do NOT use a water damp towel to clean the product and do perform the following maintenances.
- Do NOT use cleaners with alcohol, ammonia, or other damaging chemicals. The use of such chemicals can damage the product and void the warranty. Never spray or pour any liquid directly onto the product. Doing so can damage components and void the warranty.
- Use a clean, lint-free towel, dampened with a mixture of Simple Green® all-purpose cleaner, to thoroughly clean the handlebar and the console.
- This product has moving parts that can be hazardous. Exercise caution when maintaining, operating, or moving this product.
- Do not use accessories or parts that are not specifically recommended by the manufacturer (SportsArt) . Such parts might cause injuries or cause the unit to fail and void the warranty. We are not responsible for any safety issue that arises due to the misuse of accessories or parts. At the same time, we will terminate the warranty terms of this equipment.
- Maintenance and repair must be performed by trained service personnel only. Improper maintenance would not only damage the machine, but may also present a danger to the exerciser.
- Keep this product out of use until maintenance is completed.

MAINTENANCE Guide Rod Cleaning and Lubricating

1. Apply lubricant to the guide rods every week.

Procedure:

- (a) Put some lubricant on a clean, lint-free cloth. Rub the lubricated cloth on the guide rods.
- (b) Load the upper stack carriage set. Exercise to test operation.
- (c) Repeat steps (a) and (b) 2-3 times. (Note: the cloth should be lint-free.)

2. After lubricating the guide rods, inspect cable tightness. Refer to the manual, and adjust it if necessary.

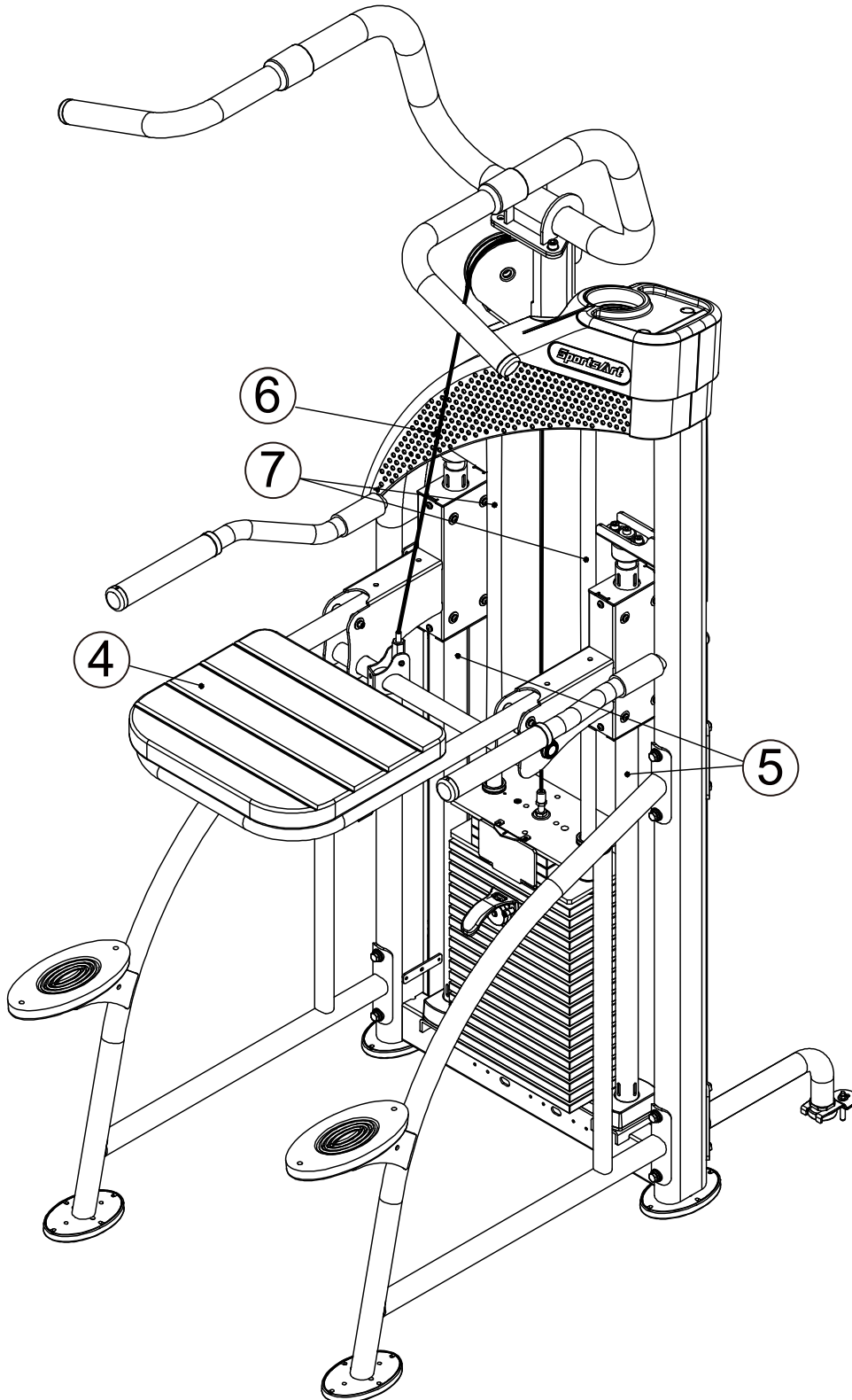

MAINTENANCE Schedule

If there is a need for maintenance of components, please visit the SportsArt website.
cleaning requirements

1.directive 93/42/CEE

2.directive biocide 98/8/CEE

The disinfectant has to be in compliance with Medical Device Directive 93/42/EEC (MDD) and Biocidal Products Directive 98/8/EC (BPD).

It is suited for sensitive synthetic surfaces such as synthetic leather, polycarbonate (PC), acrylic glass and polysulfone, and for the keyboards and control panels.

	Area	Day	Week	Month	Quarter	Year	Notes
1	Exterior	●					Clean.
2	Screws	●					Inspect for looseness and secure if necessary.
3	Test	●					Check for proper equipment operation.
4	Knee Cushions	●					Wipe clean with a damp cloth.
5	Guide Rails	●					Wipe clean with a cloth.
6	Cable		●				Check for damage or wear. Replace it if necessary.
7	Guide Rod		●				Clean and lubricate.
8	Leveling the equipment			●			Check whether the equipment is flat

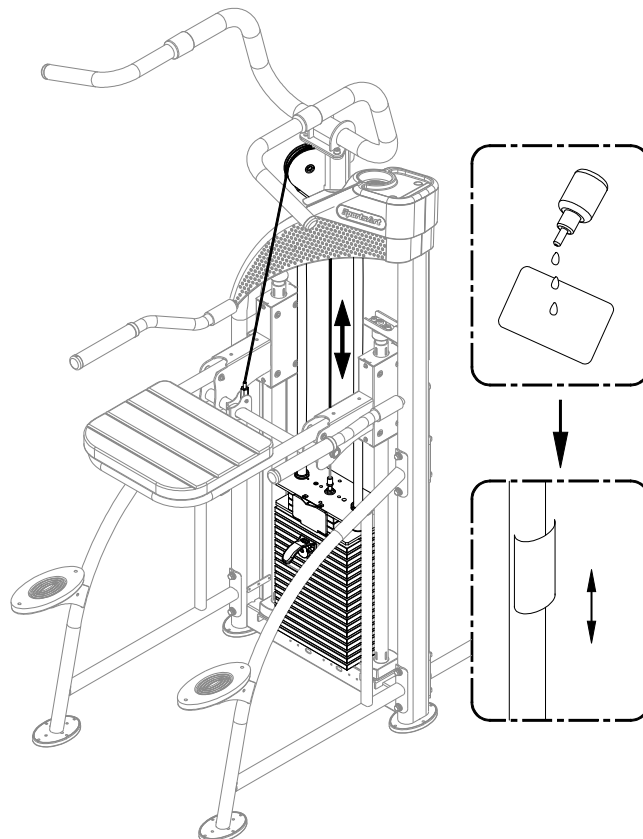

MAINTENANCE Task List

Like cars, fitness products require maintenance. Regular maintenance extends product life, and failure to maintain products can void the manufacturer's warranty. Copy the maintenance log sheet, and record maintenance work for each fitness product.

Daily tasks

1. Use a clean, lint-free towel to wipe down the product exterior.
2. Inspect all screws. Secure if necessary.
3. Make sure the machine is working properly.
4. Wipe all cushions clean with a damp cloth.

Weekly tasks

1. Check the cable for damage or tear.
2. Clean and lubricate the guide rods.

Caution

- Please follow standard safety precautions when servicing this product.
- Do NOT use cleaners with alcohol, ammonia, or other damaging chemicals. The use of such chemicals can damage the product and void the warranty. Never spray or pour any liquid directly onto the product. Doing so can damage components and void the warranty.

MAINTENANCE One-Year Maintenance Log

Facility: _____ Supervisor: _____

Product model number: _____ Serial number: _____

Start date: _____ End date: _____

Daily Tasks	Weeks 1-7	Weeks 8-14	Weeks 15-21	Week 22-28
Completed	<input type="checkbox"/>	<input type="checkbox"/>	<input type="checkbox"/>	<input type="checkbox"/>

Daily Tasks	Week 29-35	Week 36-42	Week 43-49	Week 50-52
Completed	<input type="checkbox"/>	<input type="checkbox"/>	<input type="checkbox"/>	<input type="checkbox"/>

Weekly Tasks	Weeks 1-7	Weeks 8-14	Weeks 15-21	Weeks 22-28
Completed	<input type="checkbox"/>	<input type="checkbox"/>	<input type="checkbox"/>	<input type="checkbox"/>

Weekly Tasks	Weeks 29-35	Weeks 35-42	Weeks 43-49	Weeks 50-52
Completed	<input type="checkbox"/>	<input type="checkbox"/>	<input type="checkbox"/>	<input type="checkbox"/>

Monthly tasks	1	2	3	4	5	6	7	8	9	10	11	12
Completed	<input type="checkbox"/>	<input type="checkbox"/>	<input type="checkbox"/>	<input type="checkbox"/>	<input type="checkbox"/>	<input type="checkbox"/>	<input type="checkbox"/>	<input type="checkbox"/>	<input type="checkbox"/>	<input type="checkbox"/>	<input type="checkbox"/>	<input type="checkbox"/>

Quarterly Tasks	Quarter 1	Quarter 2	Quarter 3	Quarter 4
Completed	<input type="checkbox"/>	<input type="checkbox"/>	<input type="checkbox"/>	<input type="checkbox"/>

Yearly Tasks	Year 1
Completed	<input type="checkbox"/>

Notes: _____

7. CONSIGNES DE SÉCURITÉ IMPORTANTES

Le produit SportsArt a été conçu et fabriqué afin d'assurer une sécurité optimale. Cependant certaines précautions s'appliquent chaque fois que vous utilisez votre produit.

- Lisez entièrement le manuel avant l'assemblage et l'utilisation. Veuillez aussi noter les consignes de sécurité suivantes:
- Veuillez lire attentivement les instructions et installer le produit selon les instructions.
- Assemblez et faites fonctionner le produit sur une surface solide et plane; NE PAS l'utiliser à l'extérieur ou près de l'eau.
- En aucun cas, ne laissez des enfants à proximité ou sur le produit.
- Vérifiez le tapis de course avant chaque utilisation. Assurez-vous que toutes les pièces sont assemblées et que tous les éléments de fixation sont serrés. NE PAS utiliser le produit si l'appareil est démonté de quelque façon.
- Gardez vos mains loin des pièces mobiles.
- Portez des vêtements d'entraînement appropriés; NE PORTEZ PAS de vêtements amples. NE PORTEZ PAS de chaussures à semelles en cuir ou à talons hauts. Attachez les cheveux longs.
- Soyez prudent lors du montage et démontage de l'appareil.
- NE PAS utiliser d'accessoire non spécifiquement recommandé par le fabricant. Car cela pourraient provoquer des blessures ou entraîner une panne de l'appareil.
- Débranchez l'appareil de la prise avant l'entretien ou la suppression de toute pièce.
- Une surveillance étroite est nécessaire quand le produit est utilisé par ou à proximité d'enfants, de malades ou de personnes handicapées.
- Utilisez ce produit uniquement pour l'usage prévu dans ce manuel.
- La limite de poids de l'utilisateur pour le produit est de 227 kg, 500 lb.
- Ce produit n'est pas destiné à être utilisé par des personnes (y compris des enfants) dont les capacités physiques, sensorielles ou mentales sont réduites ou qui ne disposent pas de l'expérience ou du savoir nécessaires, sauf si celles-ci ont au préalable été formées eu égard à l'utilisation de produit par une personne responsable de leur sécurité.
- Les enfants doivent être encadrés afin d'empêcher qu'ils ne jouent avec le produit.

ATTENTION

Si vous ressentez une douleur ou si vous avez une sensation anormale, ARRÊTEZ VOTRE ENTRAÎNEMENT et consultez immédiatement votre médecin. Entraînez-vous à votre niveau d'exercice recommandé. NE PAS s'entraîner jusqu'à l'épuisement. Avant de commencer un programme d'exercice, vous devriez consulter votre médecin. Il est recommandé de faire un examen physique complet. Dans ce manuel, les mots "gauche" et "droit" sont utilisés en référence aux pièces et au produit. Comme tels, les mots "gauche" et "droit" font respectivement référence aux côtés gauche et droit de l'exerciseur. De même pour plus de concision, le mot «vis» est utilisé dans certains cas où des rondelles, des vis et autres matériels sont associés.

DF-307 Assisted Chin / Dip

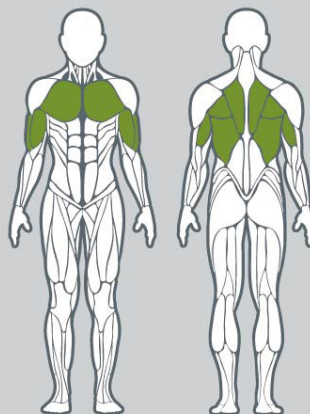
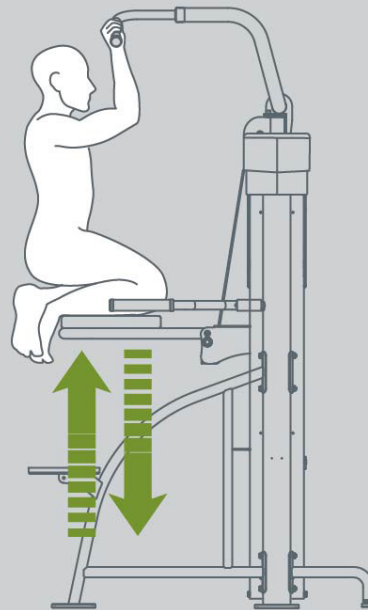
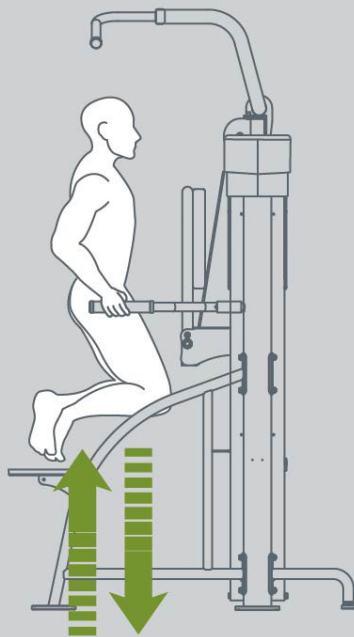

www.gosportsart.com

- 1 Select a weight that enables you to perform the movement properly.
- 2 For dips, adjust handles to desired width by rotating them in or out. For Pull ups, use overhead bar.
- 3 Place knees on the assist pad and grasp handles for desired exercise.
- 4 Pull or push yourself up in a controlled motion. Exhale when pushing against resistance.
- 5 Knee pad folds up and away for unassisted workout.

CAUTION

Do not use this machine if you are unfamiliar or do not know how to operate it. Do not allow people near this machine when in use. Keep clear of parts not intended for contact during exercise. For your safety, exhale while you exert force. Never allow unattended children on or near fitness equipment.

Your Authorized Distributor