

E876 - 16 OWNER'S MANUAL CONTENTS

1. INTRODUCTION	3
2. SAFETY PRECAUTIONS	4
3. WARNING LABEL POSITION	6
4. LIST OF PARTS	7
5. ASSEMBLE THE PRODUCT	9
STEP 1 Install the Main Frame	9
STEP 2 Install the Moving Parts	10
STEP 3 Install the Support Tubes	12
STEP 4 Install the Stationary Handlebar	13
STEP 5 Install the Console	14
STEP 6 Install the Pedals	15
STEP 7 Install the Pedestal Covers	16
STEP 8 Move the Product into Place	17
STEP 9 Level the Product	18
STEP 10 Power Cord Assembly	19
STEP 11 TV and Network Function	20
STEP 12 Beware of Moving Parts	21
STEP 13 Essential Functions Guide	22
STEP 14 Power Supply Protection(Circuit Breaker)	23
6. UNDERSTAND THE SENZA CONSOLE	24
DISPLAY Overview	24
DISPLAY Console Panel	24
DISPLAY Specifications	25
7. OPERATE THE PRODUCT	26
OPERATION Safe Operating Area	26
OPERATION Safely Get On/Off	27
OPERATION Proper Workout Position	28
OPERATION Start Screen	29
OPERATION Start your (GO) Workout	30
OPERATION Workout Selection	31
OPERATION Workout Programs	32
OPERATION During Exercise	32
OPERATION Workout Status	33
OPERATION Select Entertainment	34
OPERATION View Entertainment	35
OPERATION Workout Summary	36
OPERATION Idle Mode	36
OPERATION Energy Smart Function	36
OPERATION Precautions	36
OPERATION SA WELL+	37

E876 - 16 OWNER'S MANUAL CONTENTS

8. ABOUT HEART RATE DETECTION	38
HEART RATE Telemetry	38
HEART RATE Contact	38
9. GUIDELINES FOR EXERCISE	39
10. MAINTENANCE	40
MAINTENANCE Safety Precautions	40
MAINTENANCE Error Messages	41
MAINTENANCE Lubrication	41
MAINTENANCE Lubrication Procedure	42
MAINTENANCE Cleaning the Glide Rails	43
MAINTENANCE Schedule	44
11. ACCESSORIES	45
ACCESSORIES Standard	45
ACCESSORIES Option	46
ACCESSORIES MYE Wireless TV Audio_Channel Receivers	47
12. APPENDIXES	48
APPENDIXES Specifications	48
APPENDIXES Electronics Block Diagram	49
APPENDIXES Exploded Diagrams.....	50
APPENDIXES Disassembly	53

1. INTRODUCTION

Congratulations on the purchase of a high quality SportsArt product, the E876 16" Senza Console Elliptical trainer. Constructed of high quality materials and designed for years of reliable performance, this product was made for full commercial use.

Before this product is assembled or operated, we recommend that you familiarize yourself with this manual. Understanding the correct assembly and operation of this product will help ensure that exercisers obtain their fitness goals safely and successfully.

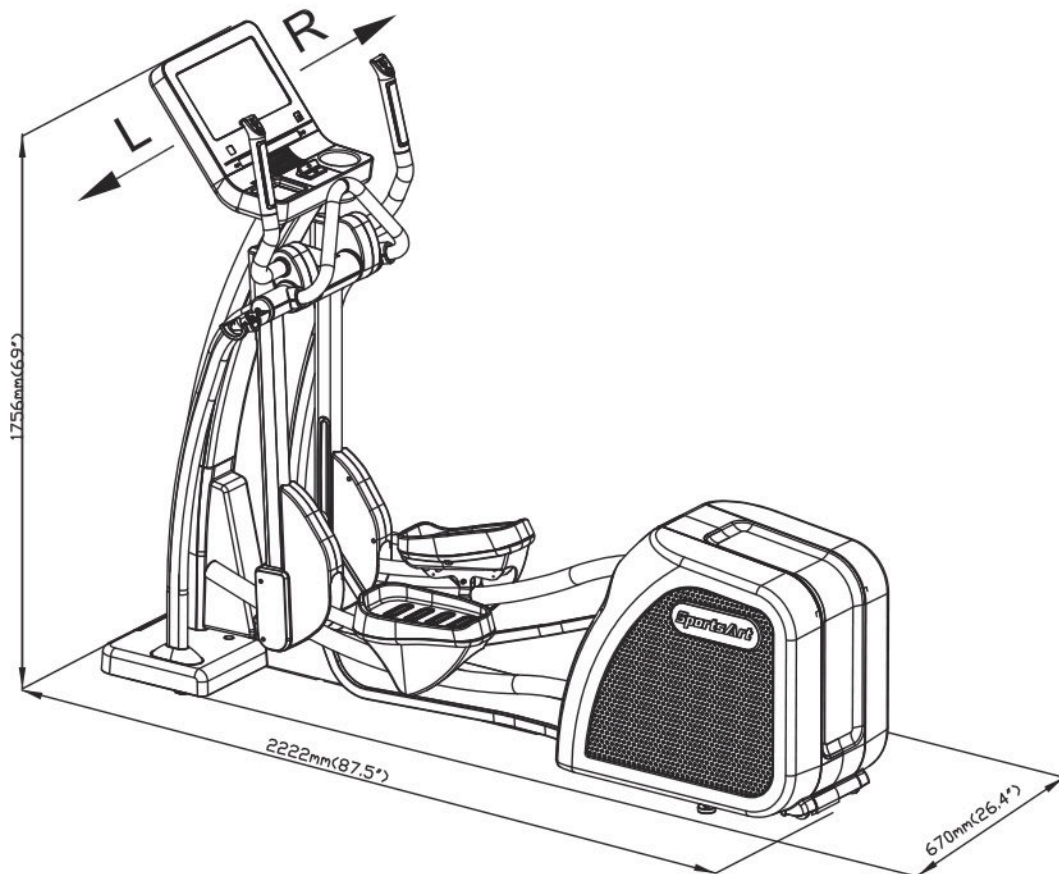

2. SAFETY PRECAUTIONS

Your SportsArt elliptical trainer was designed and built for optimum safety. However certain precautions apply whenever you use your elliptical trainer. Please read the entire manual before assembly and operation. Also, please note the following safety precautions:

- Please read the instructions carefully and install the elliptical trainer as instructed.
- Assemble and operate the elliptical trainer on a solid, level surface. DO NOT use outdoors or near water.
- Check the elliptical trainer before every use. Make sure all parts are assembled, and all fasteners are tightened. DO NOT use the elliptical trainer if the unit is disassembled in any way.
- Keep your hands away from moving parts.
- Wear proper workout clothing; DO NOT wear loose clothing. DO NOT wear shoes with leather soles or high heels. Tie all long hair back. DO NOT go barefoot on this product.
- Be careful when mounting and dismounting the unit.
- The elliptical trainer may or may not stop immediately if an object becomes caught or impedes normal motion.
- Do not use accessories or parts that are not specifically recommended by the manufacturer (SportsArt). Such parts might cause injuries or cause the unit to fail and void the warranty. We are not responsible for any safety issue that arises due to the misuse of accessories or parts. At the same time, we will terminate the warranty terms of this equipment.
- Close supervision is necessary when this elliptical trainer is used by, on, or near children 12 or younger, invalids, or disabled persons.
- Use this elliptical trainer only for its intended use as described in this manual.
- Never operate this elliptical trainer if it has been damaged in any way. If it is not working properly, or has been dropped or damaged, contact your dealer.
- Keep all air ventilation areas free of blockage.
- Never drop or insert any object into any opening.
- DO NOT operate where aerosol (spray) products are being used or where oxygen is being administered.
- The general user weight limit for this elliptical trainer is 150kg (330lb).
- Contact your SportsArt representatives on all materials damaged in shipment. (Note: Shipping damages are the responsibility of the carrier.)
- Unpack and verify contents of boxes according to the list of parts to check if any parts are missing.

2. SAFETY PRECAUTIONS (CONTINUED)

- This elliptical trainer is not intended for use by persons (including children 12 or younger) with reduced physical, sensory or mental capabilities, or lack of experience and knowledge, unless they have been given supervision or instruction concerning use of this elliptical trainer by a person responsible for their safety.
- Children 12 or younger should be supervised to ensure that they do not play on or near the product.
- Maintenance and repair must be performed by trained service personnel only. Improper maintenance would not only damage the machine, but may also may present a danger to the exerciser.
- Warning that any of the adjustment devices that could interfere with the user's movement should not be left projecting.
- To reduce the risk of injury from moving parts of electric shock, unplug before cleaning or servicing.
- **WARNING** — This stationary training equipment is not suitable for high accuracy purposes.

Caution

If you feel any pain or abnormal sensation, **STOP YOUR WORKOUT** and consult your physician immediately. Work within your recommended exercise level. **DO NOT** work to exhaustion.

Before beginning any exercise program, you should consult with your doctor. It is recommended that you undergo a complete physical examination. **DO NOT** step onto the highest footplate. While holding onto supports for stability, step onto the lowest footplate.

Note: This equipment has been tested and found to comply with the limits for a digital device, pursuant to part 15 of the FCC Rules. These limits are designed to provide reasonable protection against harmful interference in a residential installation. This equipment generates, uses, and can radiate radio frequency energy and, if not installed and used in accordance with the instructions, may cause harmful interference to radio communications. However, there is no guarantee that interference will not occur in a particular installation. If the user desires to correct such interference, it is at the user's own expense.

Warning

Heart rate monitoring systems may be inaccurate. Over exercise may result in serious injury or death. If you feel faint, stop exercise immediately.

3. WARNING LABEL POSITION

If you are in a Non-English speaking country, you can attach the warning label to the console panel as shown, otherwise, you can also stick it on a place where is clear and obvious. (please use the French version label in French-Speaking areas in North America, and the label will not be included in the other regions.)

Note: Depending on the model, the appearance of the console is different, but the labeling position is the same.

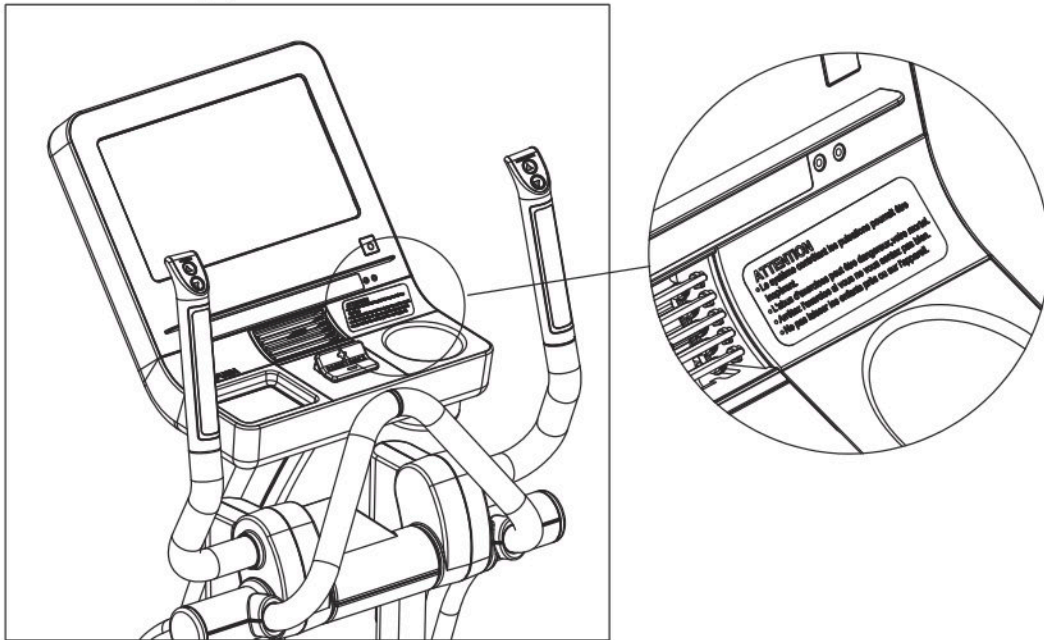

4. LIST OF PARTS

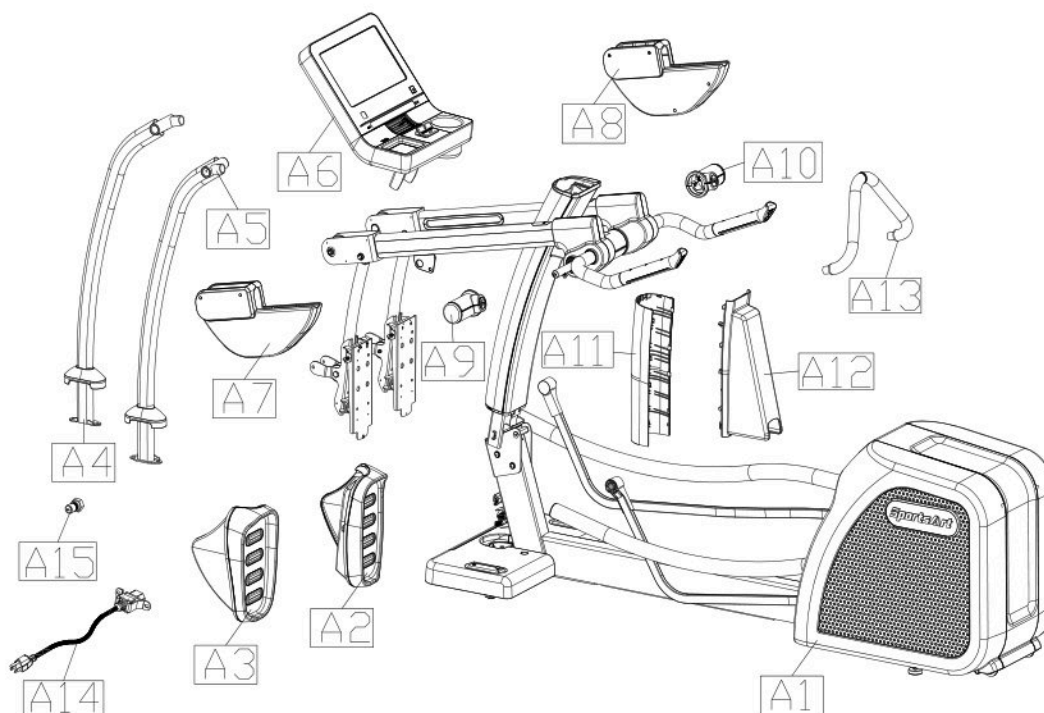

Assembly Parts					
No.	Name	Qty.	No.	Name	Qty.
A1	Main frame	1	A9	Left joint cover	1
A2	Right pedal	1	A10	Right joint cover	1
A3	Left pedal	1	A11	Pedestal cover B	1
A4	Left support tube	1	A12	Pedestal cover E	1
A5	Right support tube	1	A13	Stationary handlebar	1
A6	Console	1	A14	Power cord	1
A7	Left roller cover	1	A15	TV Terminal	1
A8	Right roller cover	1			

4. LIST OF PARTS (CONTINUED)

TOOLS KIT				
No.	Name	Qty.	Specification	Notes
10	Inner hex screw	6	M10*P1.5*L25	
	Spring washer	6	M10	
	Washer	6	D21*d10.5*t1.5	
11	Stride adjustment linkage cover	2		
12	Hex nut	2	M10*P1.5	
	Stopper	2	Ø30-30	
13	Secondary roller bolt	2	D9.96*L67	
	Self-lubricating bushing	4		
	Secondary roller	2	D58*t23	
	L-shaped Allen wrench	1	M4	
	L-shaped Allen wrench	1	M5	
	T-shaped Allen Wrench	1	M6*L108	
	Double Open-End Wrench	1	8mm*17mm	
	Double Open-End Wrench	1	14mm*15mm	
	Screwdriver handle	1	black	
	Screwdriver bit	1	Flat and Phillips	
Pre-Installed Hardware				
No.	Name		Specification	Notes
21	Phillips screw		M4*P0.7*L8	
22	Inner hex screw		5/16"*L2-1/4" half	
	Flat washer		D20*d8*t2.0	
23	Inner hex screw		M6*L15	
	Handlebar washer		D20*d7*t2.0	
24	Mushroom top inner hex screw		M8*L15	
	Flat washer		D17*d8.3*t2	
	Spring washer		M8	
25	Inner hex screw		M6*L15	
	Handlebar washer		D20*d7*t2.0	
26	Phillips screw		M5*P0.8*L15	
27	Mushroom top Phillips screw		M5*0.8*L16	
28	Pedestal cover			
29	Inner hex screw		M8	
30	Mushroom top philips screw		M4*L12	
31	Mushroom top Phillips screw		M5*0.8*L15	
32	Inner hex screw		M5*L16	
33	Phillips Head Screw		M4*P0.7*L8	

5. ASSEMBLE THE PRODUCT

STEP 1 Install the Main Frame

- (a) Unfold the main frame (A1) and make it stand.
- (b) Secure screws (10) to the main frame.

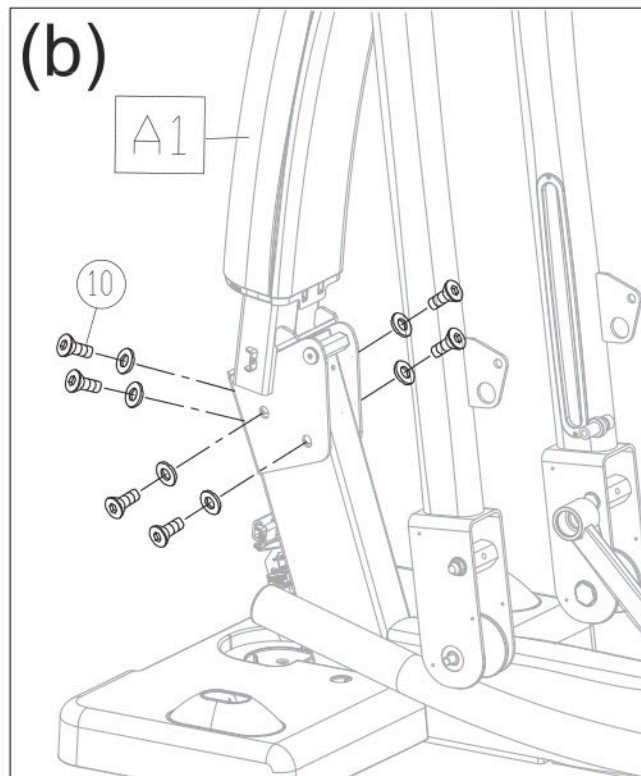
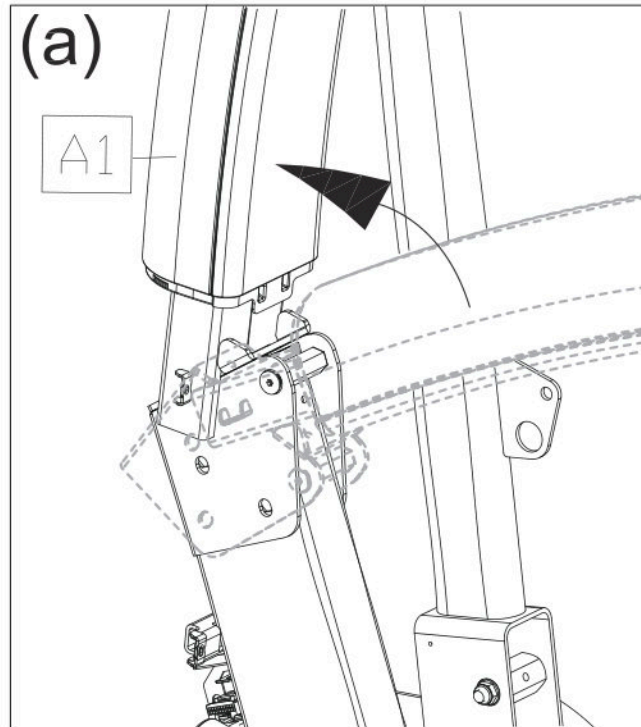

STEP 2 Install the Moving Parts

Follow instructions (a) through (f) to install the moving parts.

- (a) Remove screws (21) from the pedal arm attached to the main frame (A1).
- (b) Slip the glide rail into (area A), then gently place the pedal carriage on the glide rail support.
- (c) Connect the guide roller (13) on the bottom of the glide rail. (NOTE: insert the axle from the outside to the inside.)

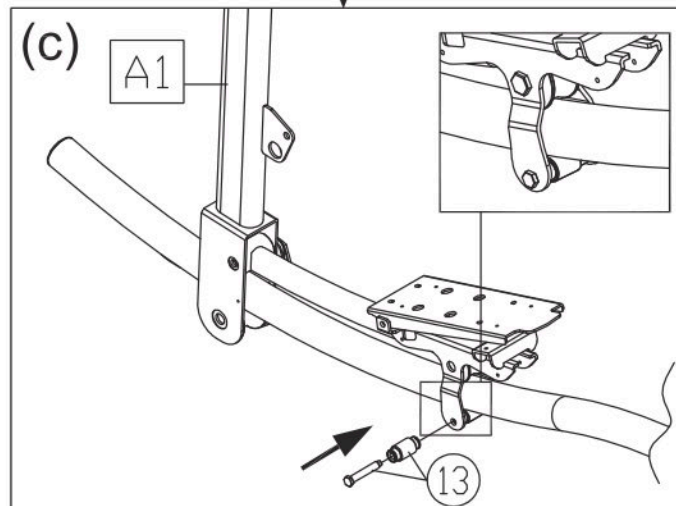
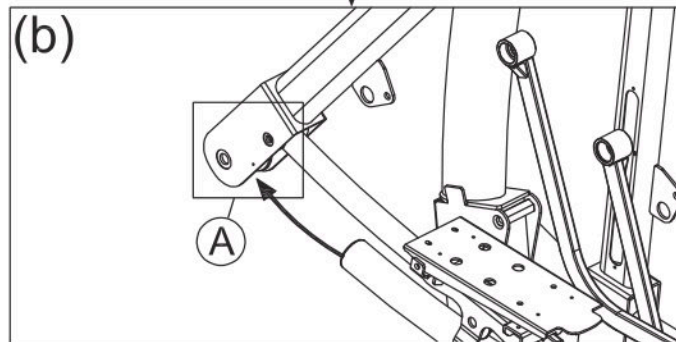
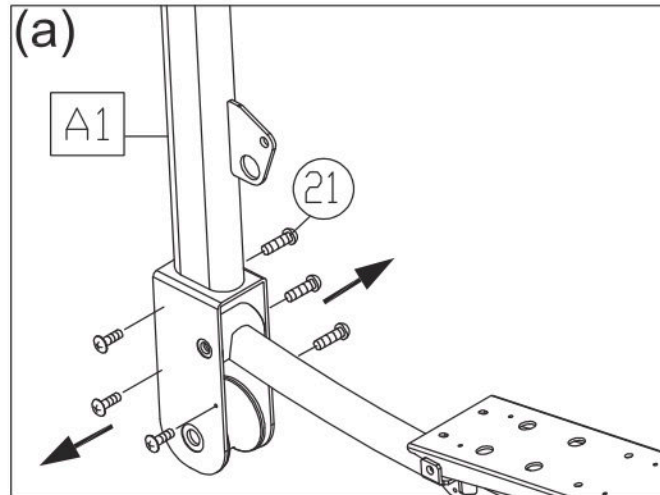

STEP 2 Install the Moving Parts (Continued)

- (d) Separate the roller covers (A7). Snap them together into place on the product. Then secure them with screws (21).
- (e) On the left side of the product, remove the screw (22) from the stride adjustment linkage. Place the stride adjustment linkage into place on the bushing, and use the screw (22) to secure it into place. Then press the stride adjustment linkage cover (11) into place. (Note: Carry out the same procedure on the right side of the product as well.)
- (f) Secure the stopper (12) to the front side of the glide rail on both sides of the product.



Consult the manual and follow all assembly instructions carefully. Please note that incorrect assembly may present a danger to the exerciser, will damage the elliptical and void the warranty.

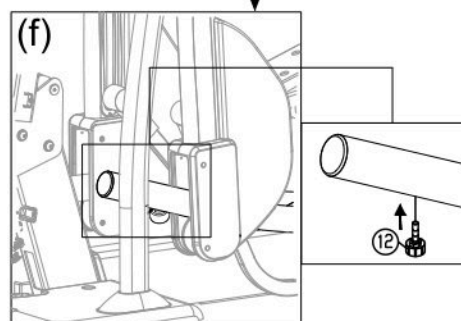
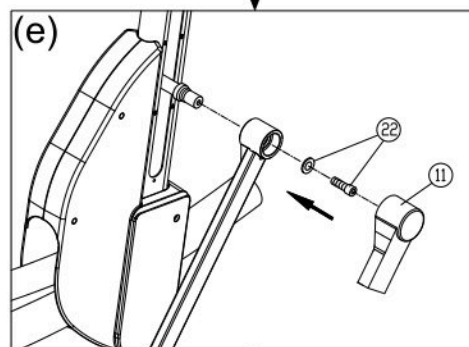
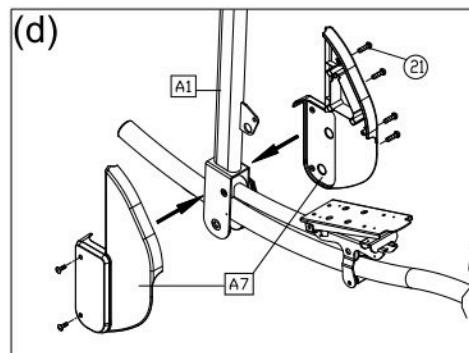

STEP 3 Install the Support Tubes

Follow steps (a) through (b) to install the support tubes.

(a) Remove support tube screws (23) (24) from the main frame (A1).

(b) Insert left and right support tubes (A4,A5) into the axle area and base, and loosely secure them into place with screws (23) (24)

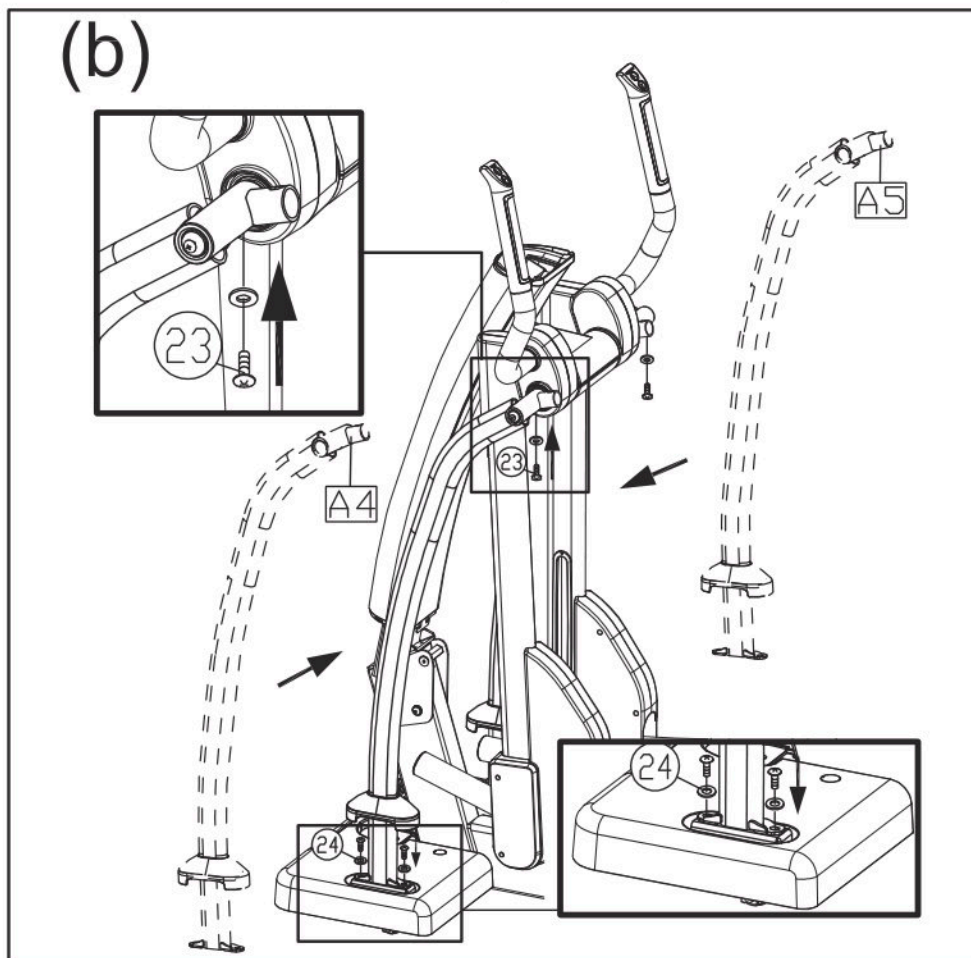
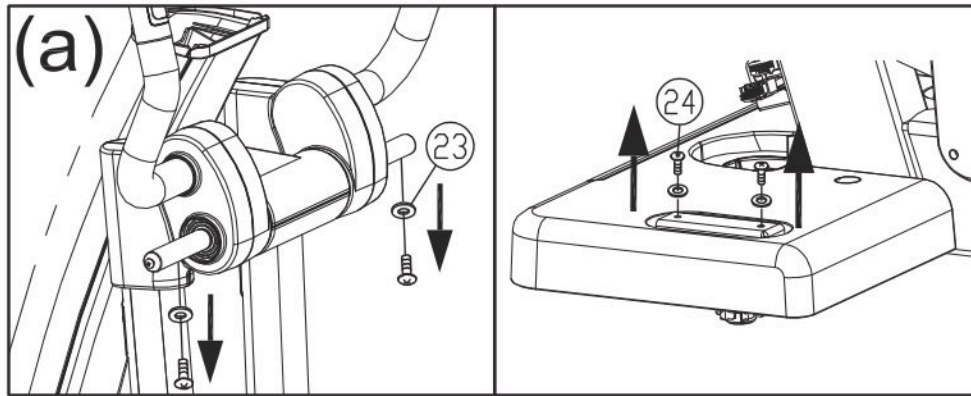

STEP 4 Install the Stationary Handlebar

Follow instructions (a) through (c) to install the stationary handlebar and secure the support tubes.

- (a) Remove screws (25) from the stationary handlebar (A13). Insert the stationary handlebar (A13) into place on the support tubes, and secure them with screw (25).
- (b) Remove screws (26) from the sides of the left and right support tubes (A4) (A5). Snap joint covers (A9) (A10) together from top to bottom, and use screws (26) to secure them.
- (c) Tightly secure screws in (area B), and insert the support tubes into the base frame by a straight downward push.

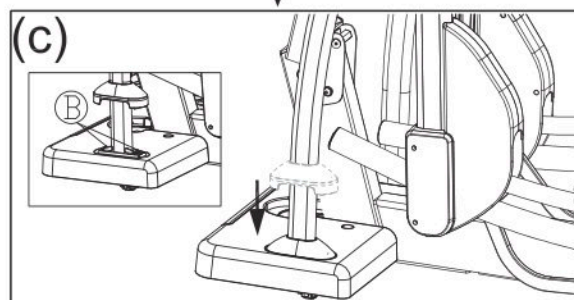
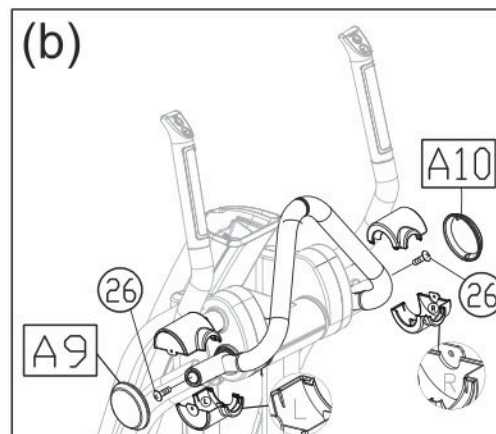
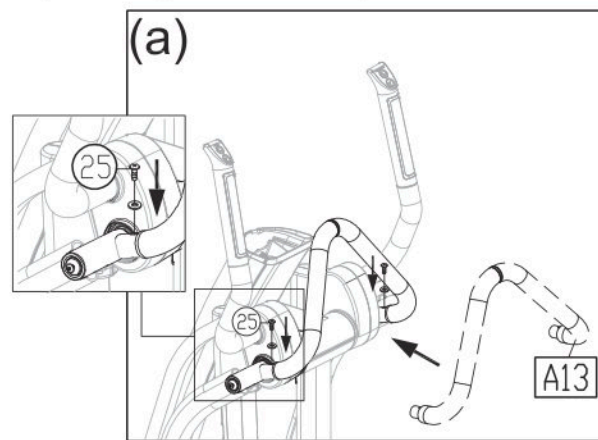

STEP 5 Install the Console

Follow instructions (a) through (c) to install the console.

- (a) Remove screws (27), then pull the pedestal cover (28) upward and remove it.
- (b) Connect the cables of the console to the pedestal, and then secure the console into place with screw (29).
- (c) Connect the cables of the main frame to the cables of the console (A6), and then tuck the cables back into the pedestal.

NOTE: Do not unpack the cables if the console is not secured.

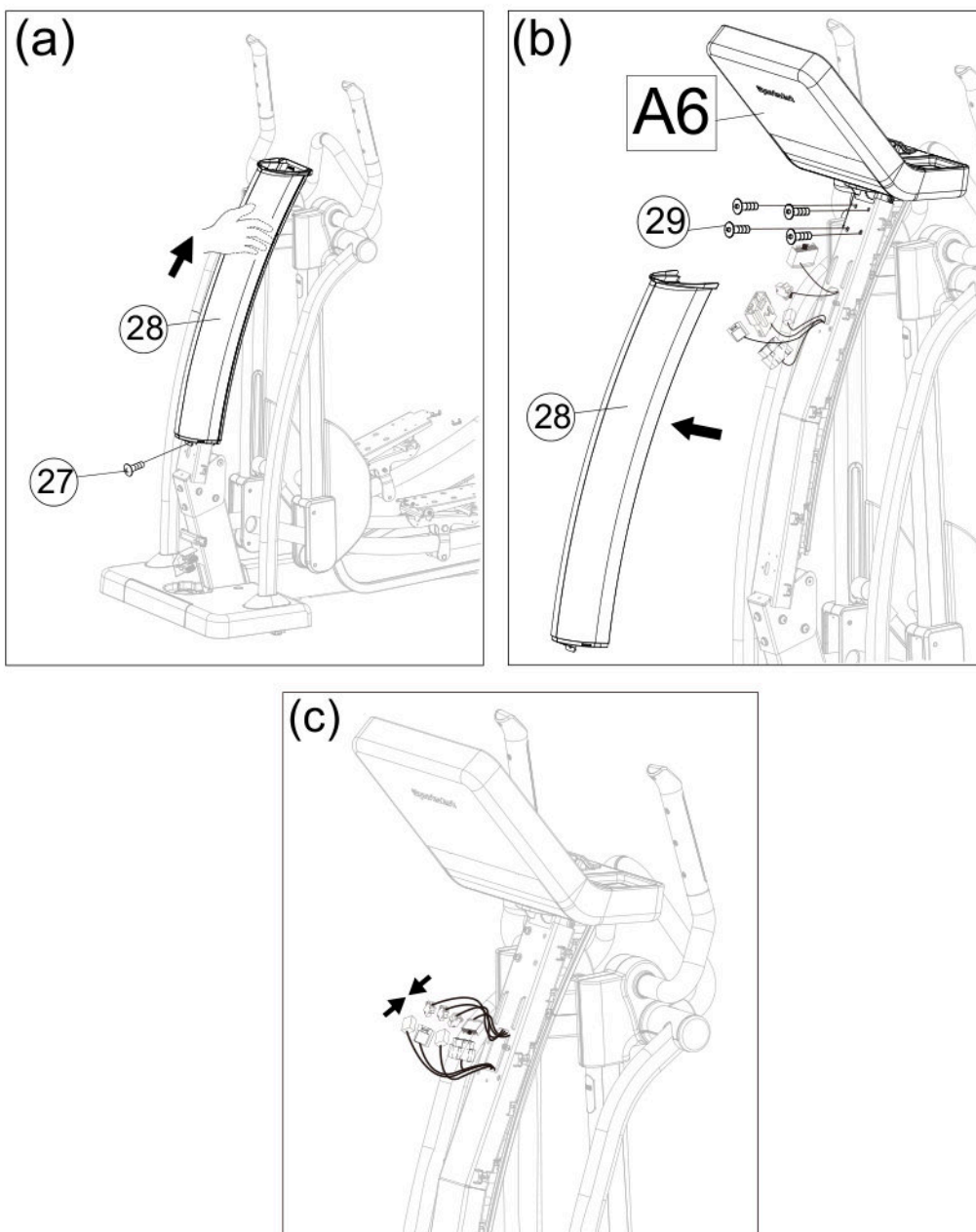

STEP 6 Install the Pedals

Follow instructions (a) through (d) to install the pedals.

- (a) Vertically split the right pedal (A2) with upper and lower halves, and then remove the non-slip pads on it. Repeat the same step with the left pedal.
- (b) Install the lower half of the right pedal (A2) at a tilt angle as shown below, and then press it into place. Repeat the same step with the left pedal.
- (c) Secure the lower half of the right pedal with screw (31), and be sure to secure the screws in the rectangular frame shown in figure (c) first. Repeat the same step with the left pedal.
- (d) Align the upper half of the right pedal to the lower half, and secure them with screw (32), then install the non-slip pads to the upper half of the right pedal. Repeat the same step with the left pedal.

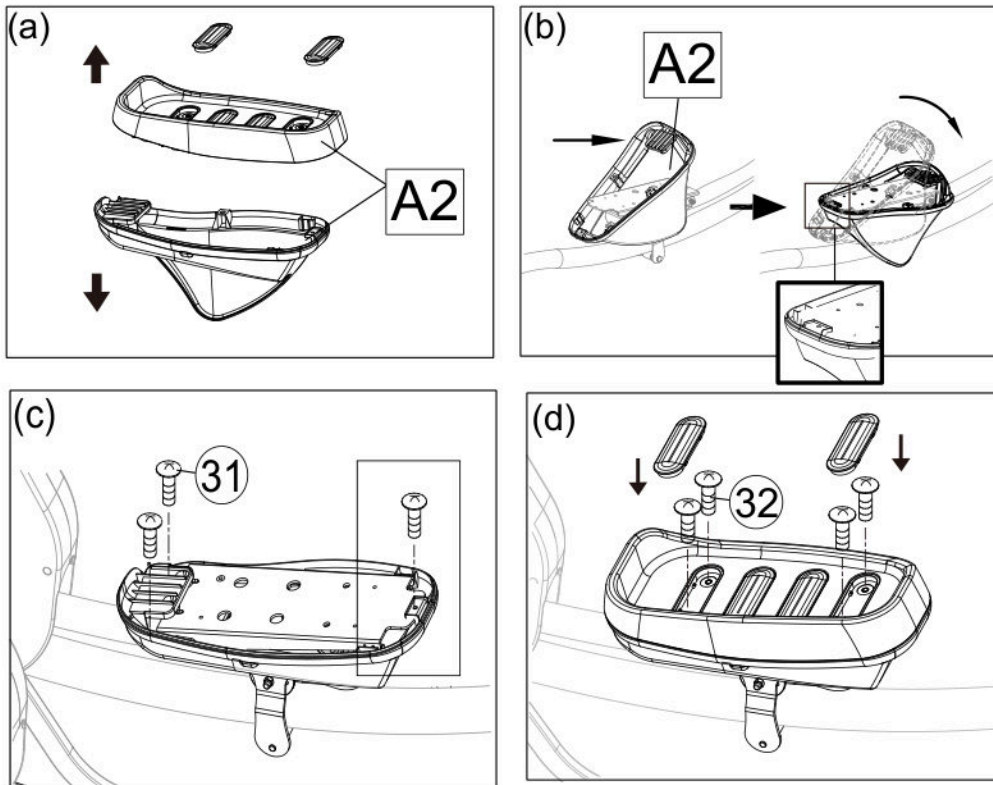

STEP 7 Install the Pedestal Covers

Follow instructions (a) through (b) to install the pedestal covers.

- (a) Insert the pedestal cover (28) to the console at a tilt angle as shown in figure (a), and then place the pedestal cover onto the mount by a downward push. Once it is locked completely, secure it with screw (27), and then secure the pedestal cover E (A12) with screw (30).
- (b) Insert the pedestal cover B (A11) to the base frame at a tilt angle as shown in figure (b), and then engage the pedestal cover B with pedestal cover E (A12). Once it is locked completely, fix it firmly in position by an upward push.

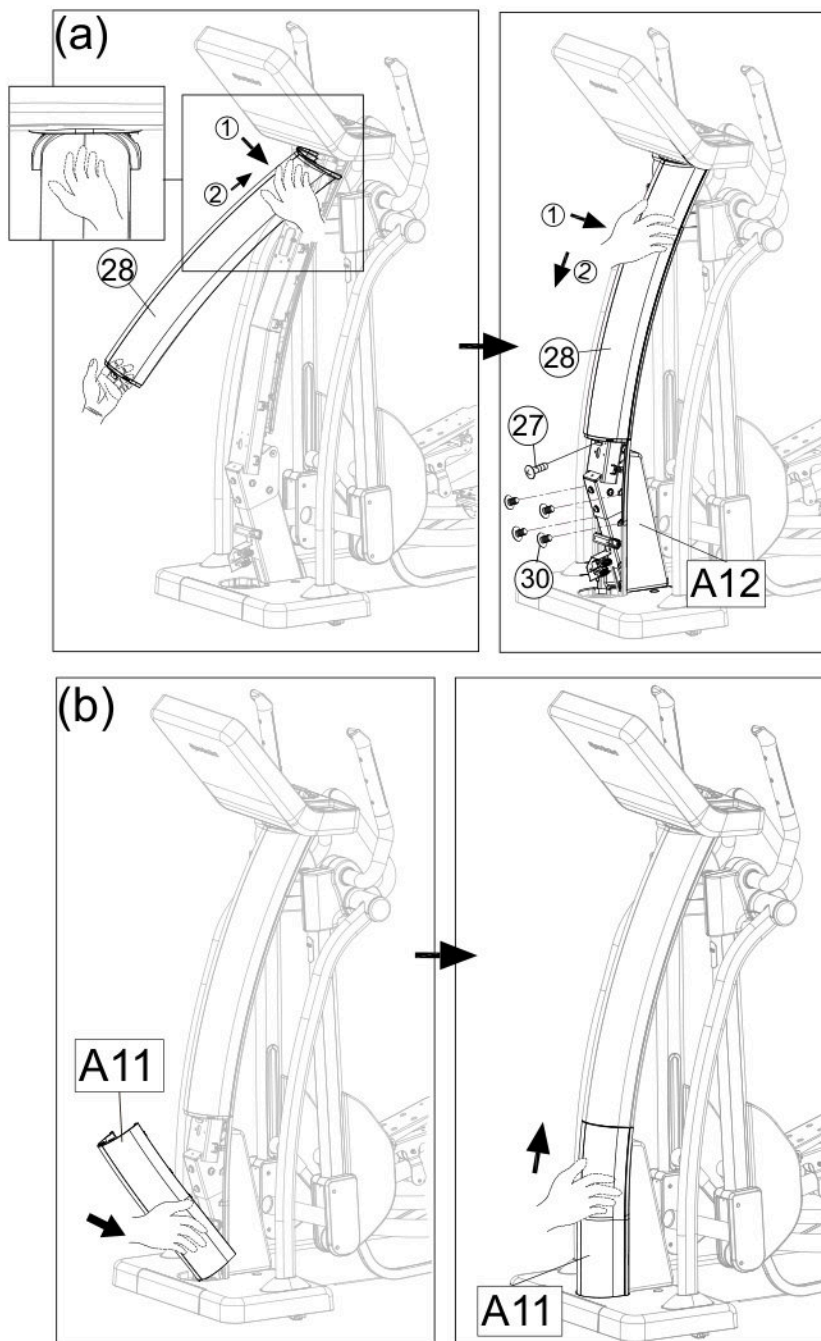

STEP 8 Move the Product into Place

There are two techniques for moving this product.

- (a) One person: Grip the front base of the product and lift upward, then push the product into location for use. Be careful to avoid pinching fingers when setting the product down.
- (b) Two people: Have one person grip the front base of the product while the other person grips the support tubes. With both people lifting and stabilizing the unit, roll it into place for use. Be careful to avoid pinching fingers when setting the product down.

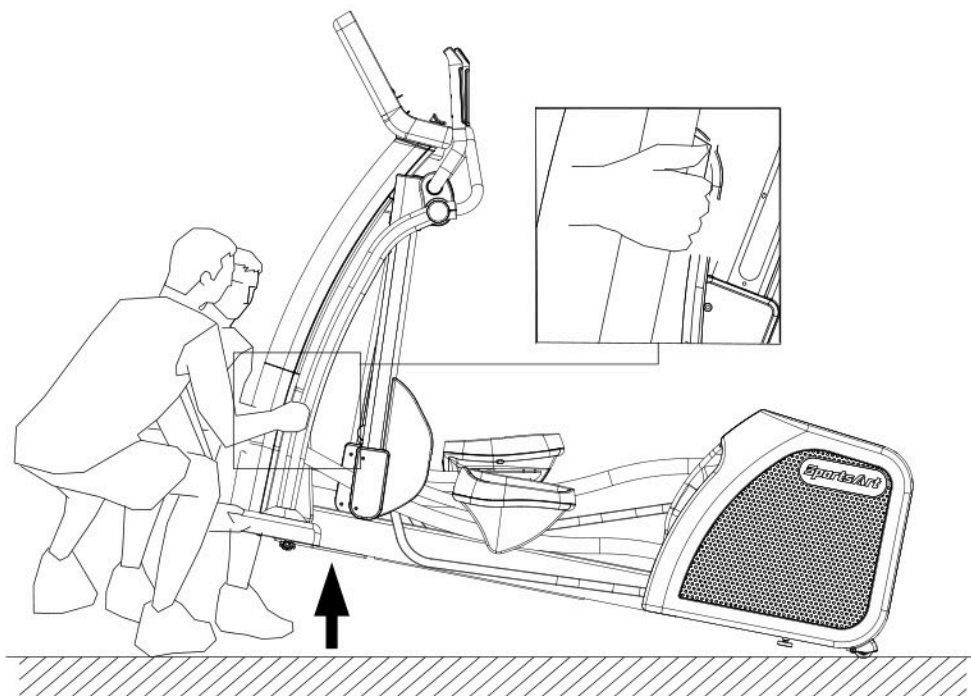
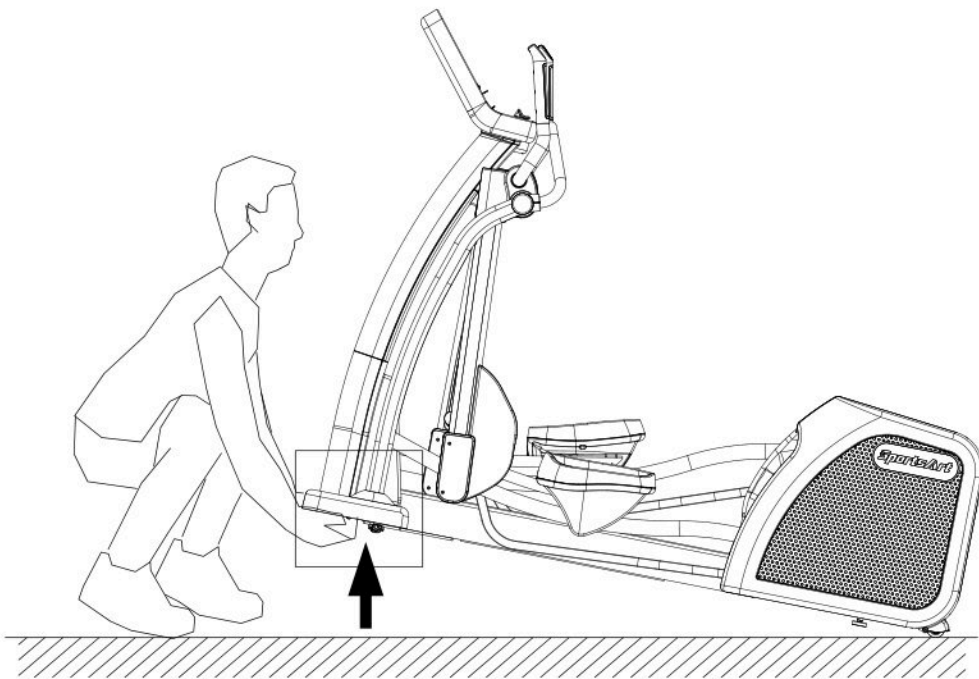

STEP 9 Level the Product

For the user's safety and the proper functioning of the product, this elliptical trainer must sit level on a flat floor. If necessary, adjust the levelers by following instructions (a) through (c) below.

- (a) Loosen the leveler nut.
- (b) Rotate the leveler foot downward so it firmly touches the floor.
- (c) To secure this position, secure the leveler nut upward against the product frame.

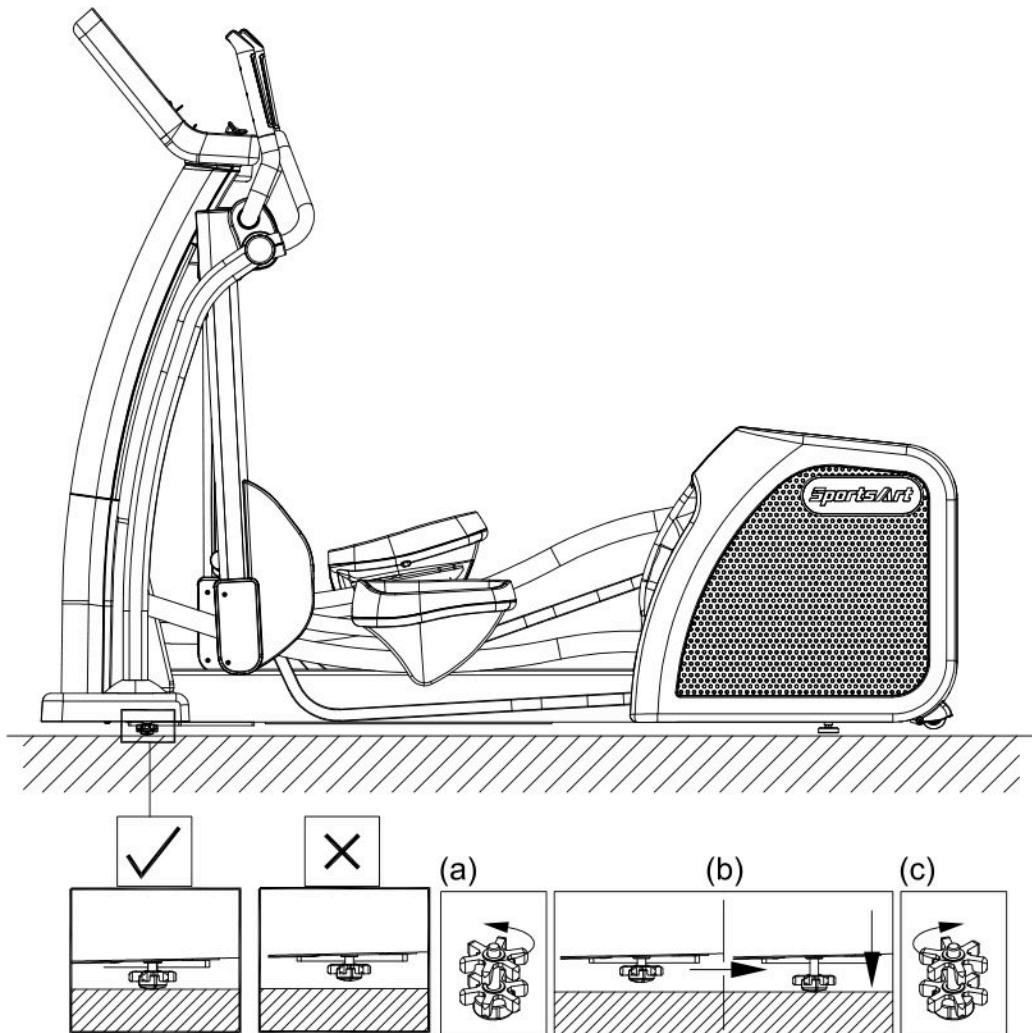

STEP 10 Power Cord Assembly

- (1) Please remove the pre-installed screws (33) from the machine prior to assembly.
 - (2) Push the plug cover of the power cord toward and against the plug.
 - (3) Plug in the power cord (A14) and secure it with the screws (33).
- The picture below is for your reference.

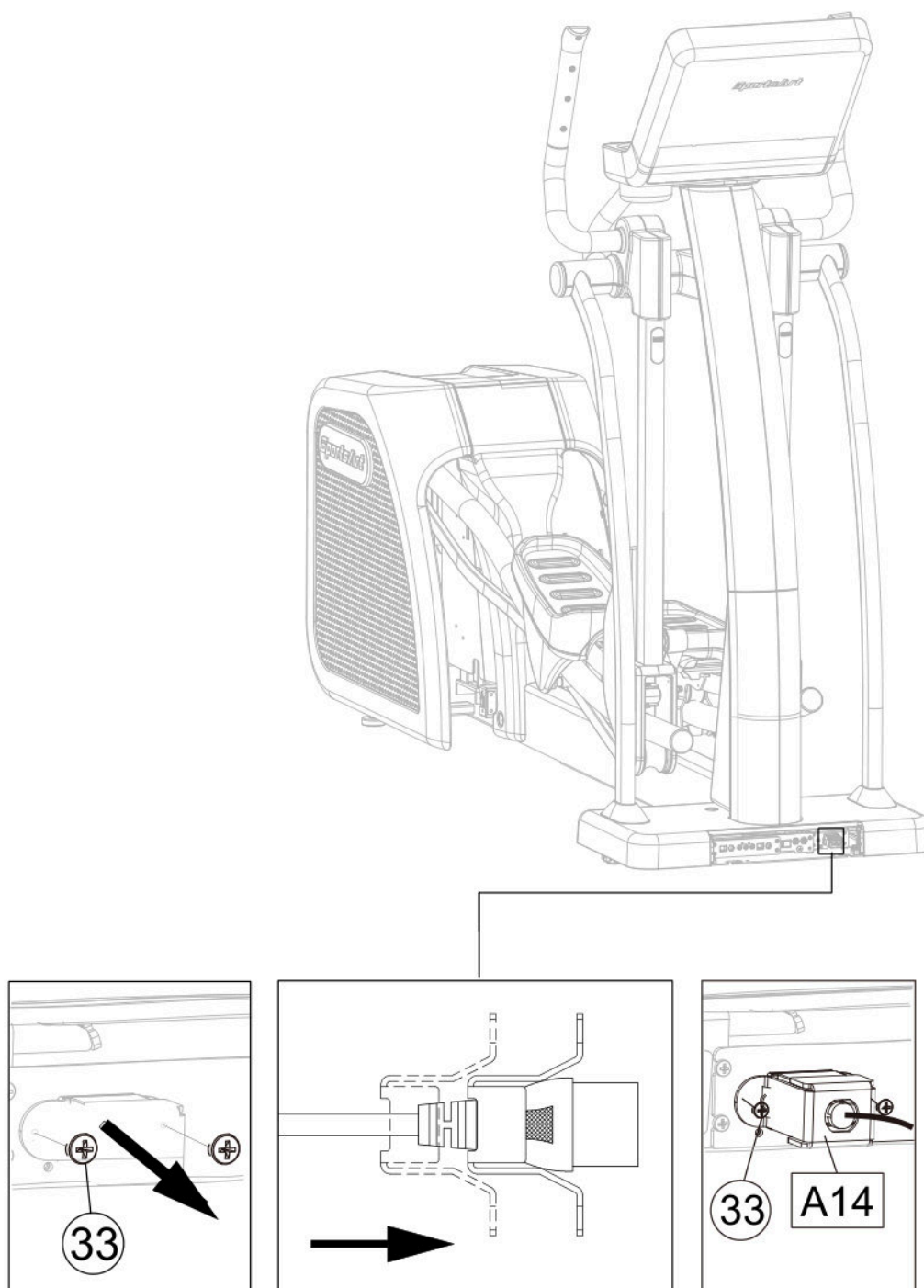

STEP 11 TV and Network Function

- (a) NETWORK: Connect to the Ethernet with the external network signal.
- (b) AV PORT: To support external DVD PLAYER or other multimedia players using AV output signal.
- (c) To support MYE Wireless TV Audio_Channel Receiver, and the other equipment that conform to the CSAFE specification.
- (d) TV : This machine can connect to digital TV and analog TV (for NTSC system). For PAL system, please take out the TV adapter(A15) from tools kit and connect it to TV with cables.

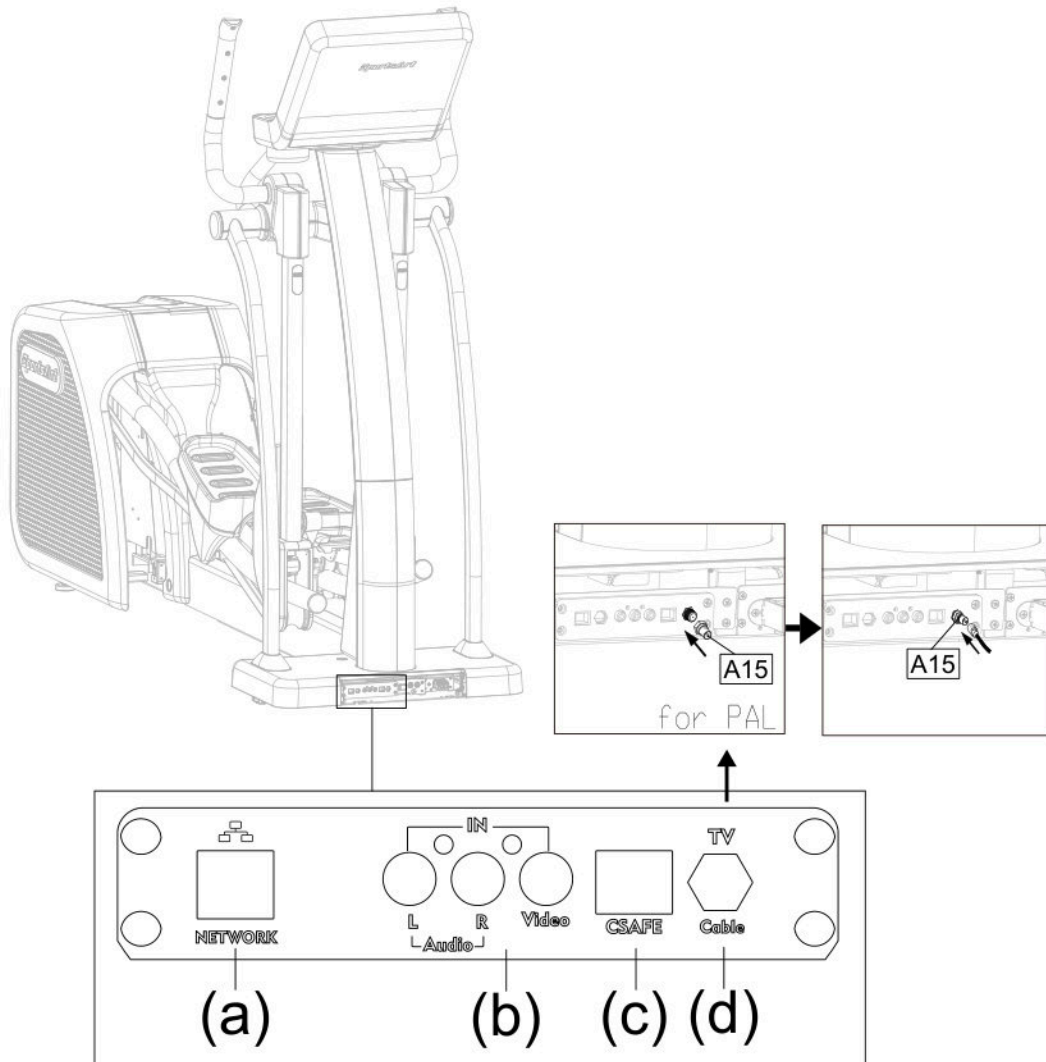

STEP 12 Beware of Moving Parts

This product has moving parts that could be a danger to people and animals.

During use, do not put hands or other objects into the stride adjustment slot, the rear cover opening, or other areas in which such action might present a hazard.

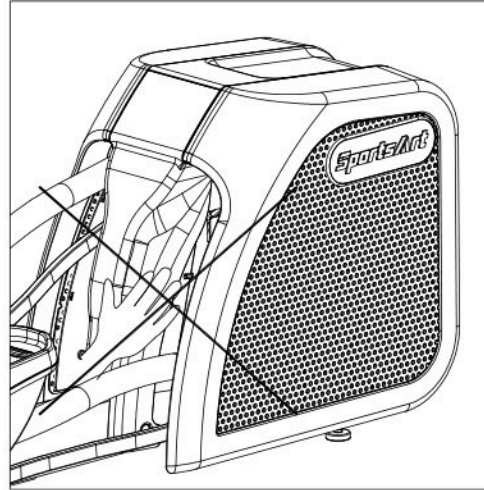
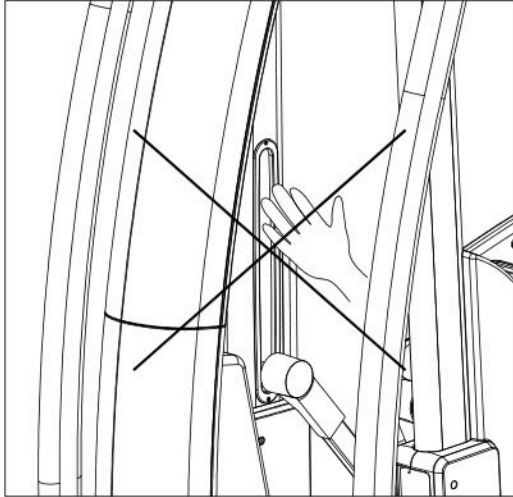

STEP 13 Essential Functions Guide

LENGTH: Adjust the distance between two successive placements of the same foot.

RESISTANCE: Adjust the weight or force you need to place on the pedals to push them.

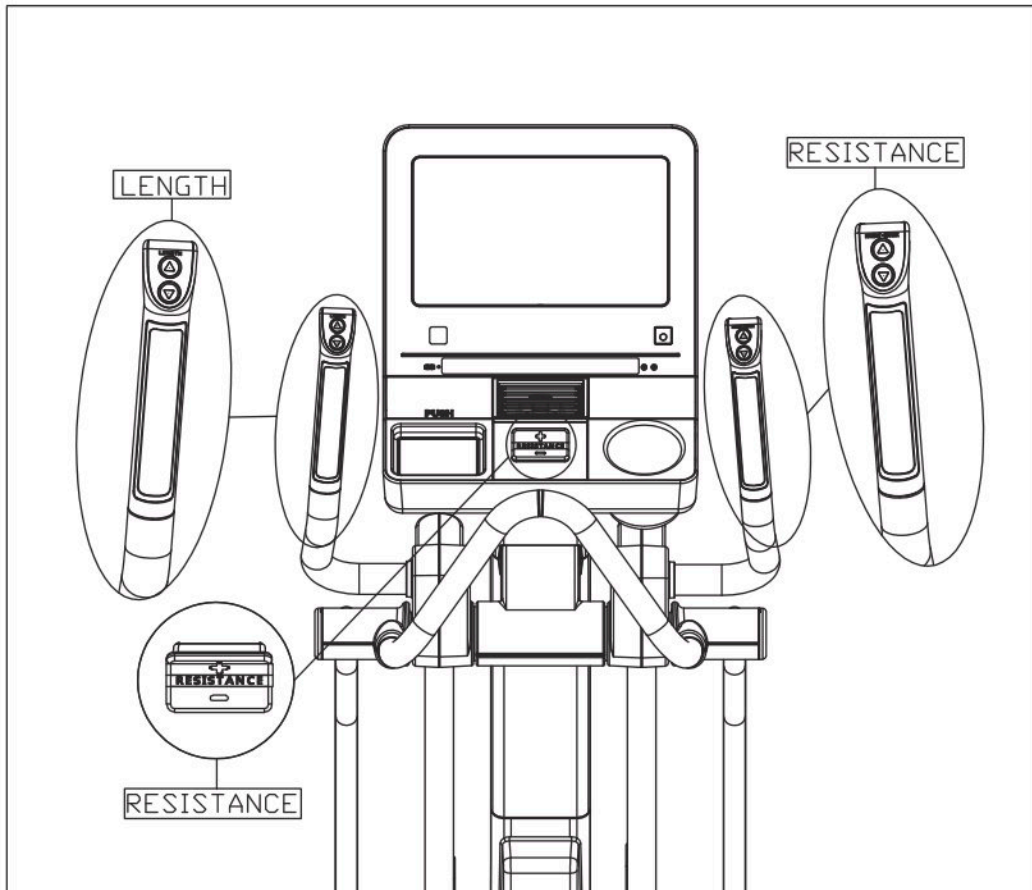

STEP 14 Power Supply Protection(Circuit Breaker)

When current is overloaded, the Circuit Breaker will work to protect the machine from damage. In the following picture (a) you will find a round button(D), which is the device of circuit breaker, it will pop up when current is overloaded, please turn off the machine in this situation. After the maintenance personnel find and solve the problems, press the button as shown in picture (b), then restart the machine to back on exercising.

The picture below is for your reference.

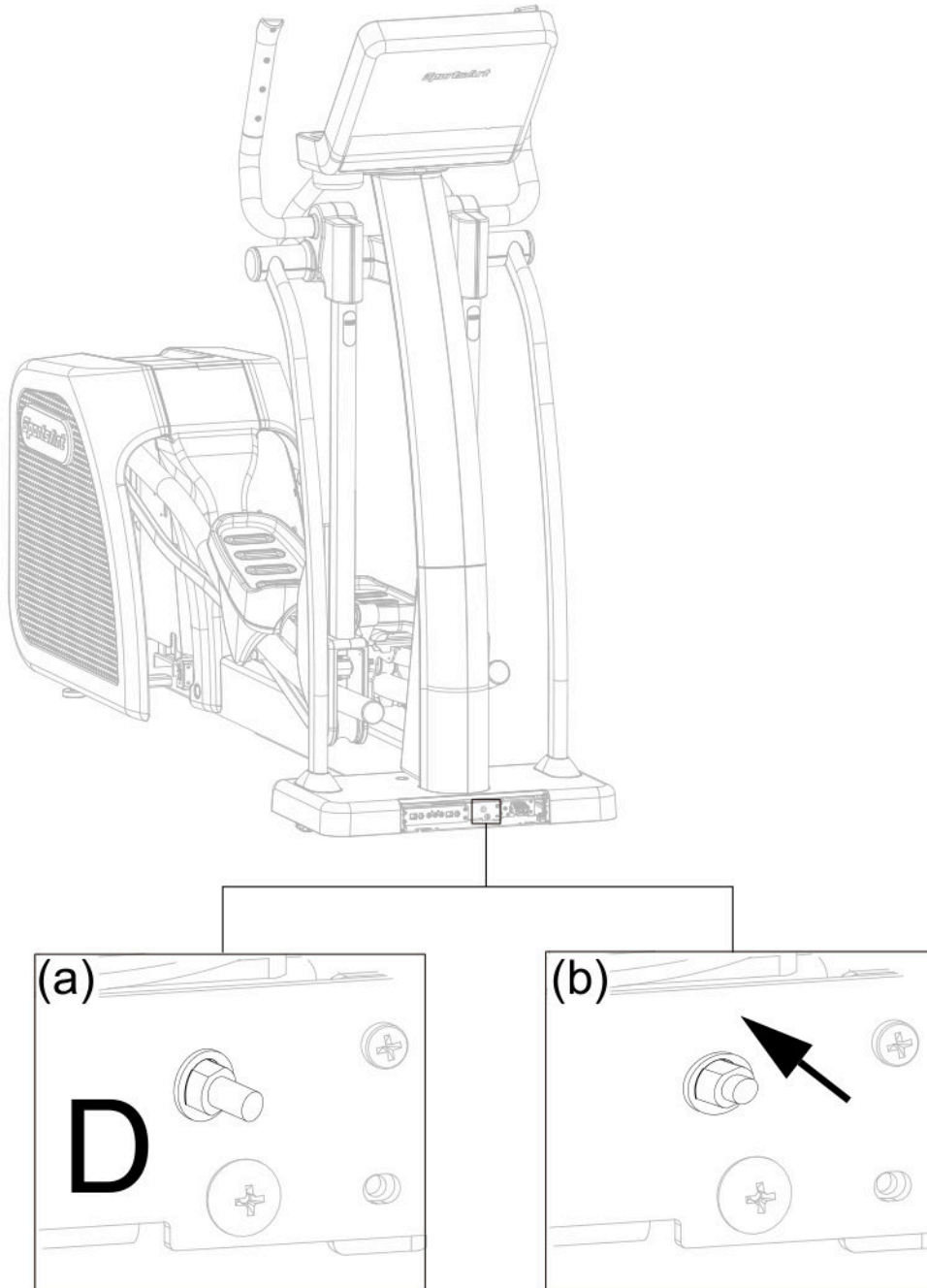

6. UNDERSTAND THE SENZA CONSOLE

DISPLAY Overview

E876 Series 16" Senza Console is designed to help users obtain their fitness goals in a simple and convenient way. Before using the elliptical trainer, please familiarize yourself with the functions of this display console to obtain optimum benefits and enjoyment from this product.

DISPLAY Console Panel



No.	Title	Function
1	QR code and NFC tag	(1) Without the SA WELL+: Only link to SPORTSART website when scanning the QR CODE and NFC label. (2) With the SA WELL+: Use the APP on your mobile scanning the QR CODE and NFC label to connect to the elliptical trainer to your personal exercise records.
2	USB Port	Used for software updates but can also be used as a charging port.
3	SA WELL+ Device	Data management (This function is only available if you purchase SA WELL+)
4	RESISTANCE+ -	Press <RESISTANCE +/-> to set the resistance.
5	Wake Button	Press this key to wake-up the console panel.
6	Headphone Port	The user can listen to audio or music after inserting a headphone.

DISPLAY Specifications

Parameter	Spec.
SPEED	0.1 mph (kph)
RESISTANCE	1-40
STRIDE LENGTH	450 - 730mm or 17" - 29"
CAL/HR	0-9999 K-CAL
TIME	0:00-600:00
DISTANCE	0.00-9999 Mile/KM
CALORIES	0-9999 K-CAL
SPM	5-150
HEART RATE	35-220 bpm
TOTAL STRIDES	0 - 9999

7. OPERATE THE PRODUCT

OPERATION Safe Operating Area

- (a) Safety clearance required as shown below. Do not allow people to be near this area when operating.
- (b) Noise emission under load is higher than without load.

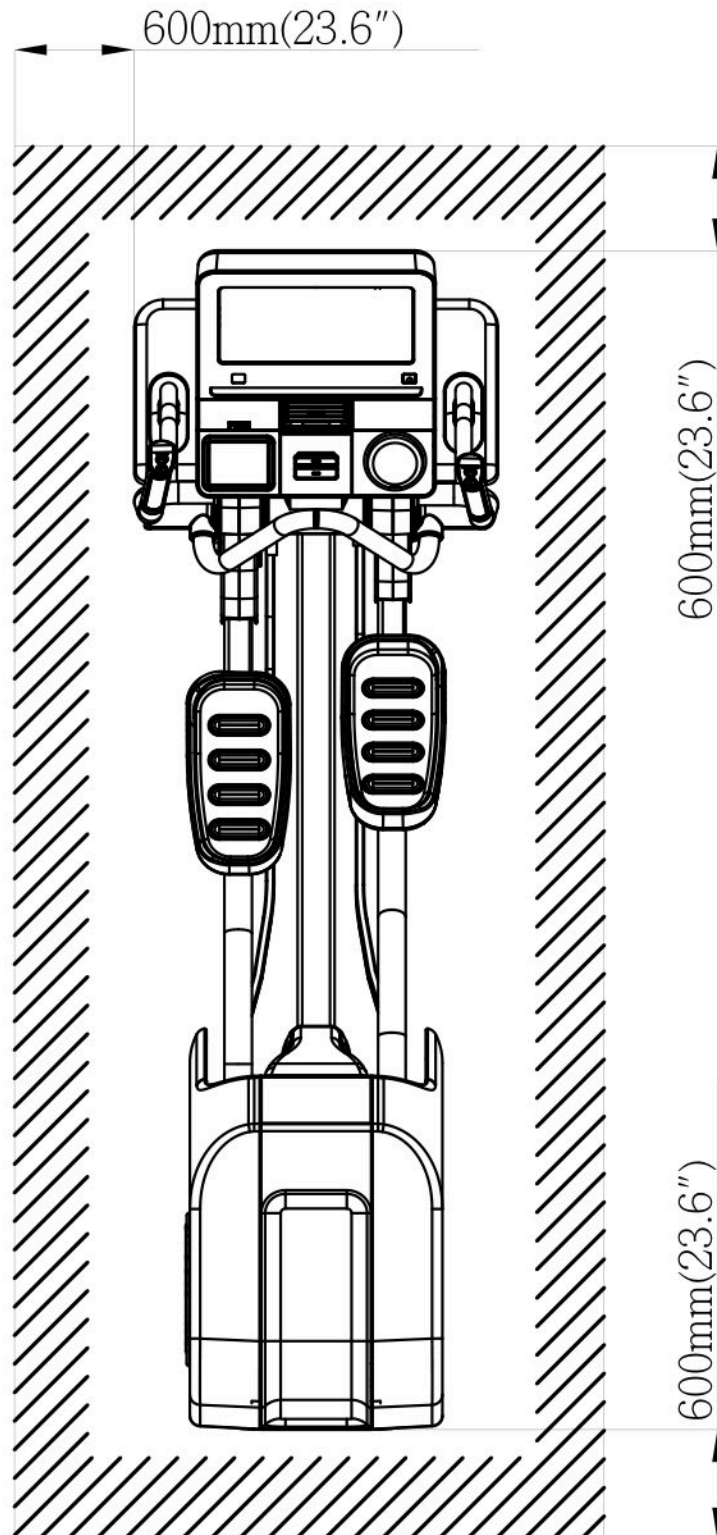

OPERATION **Safely Get On/Off**

- (a) Place your feet on floor and then hold the handles to steady self while stepping on the pedals as shown below.
- (b) Wait until pedals come to a complete stop and then hold onto handles for stability while carefully stepping off the elliptical.

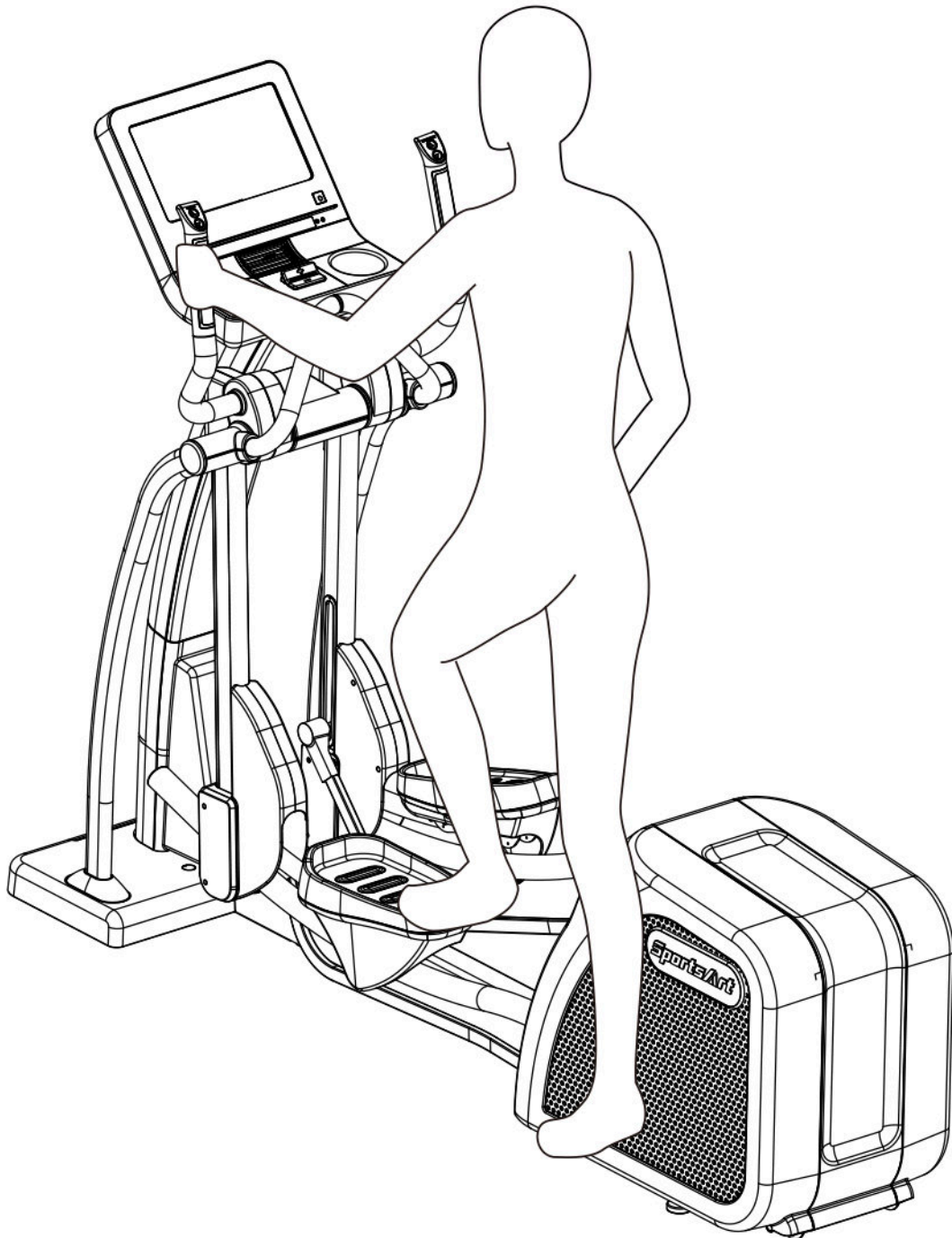

OPERATION **Proper Workout Position**

- (a) Proper workout position for user is shown below.
- (b) Over exercising or improper workout form may result in serious injury.
- (c) User can hold onto handles for stability when getting on or getting off from the right/left side of the elliptical.
- (d) This product is intended for exercise arms and legs.

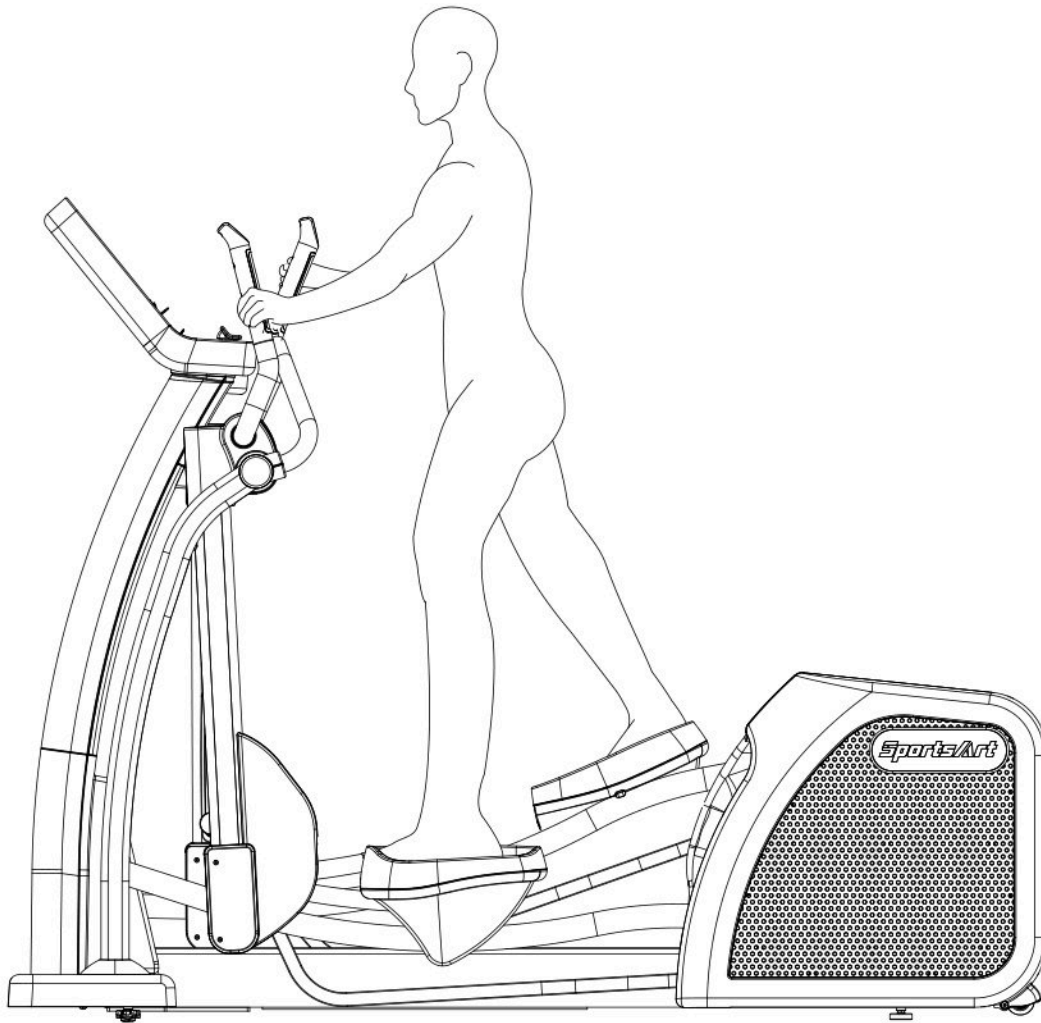

OPERATION Start Screen

Touch screen design is simple and clear. The screen layout helps users focus on exercise. It provides many workout modes that can help you achieve your fitness goal. The following sections introduce information concerning touch screen operation, the available types of workout, and how to start the workouts.

This screen will appear when the machine is turned on.

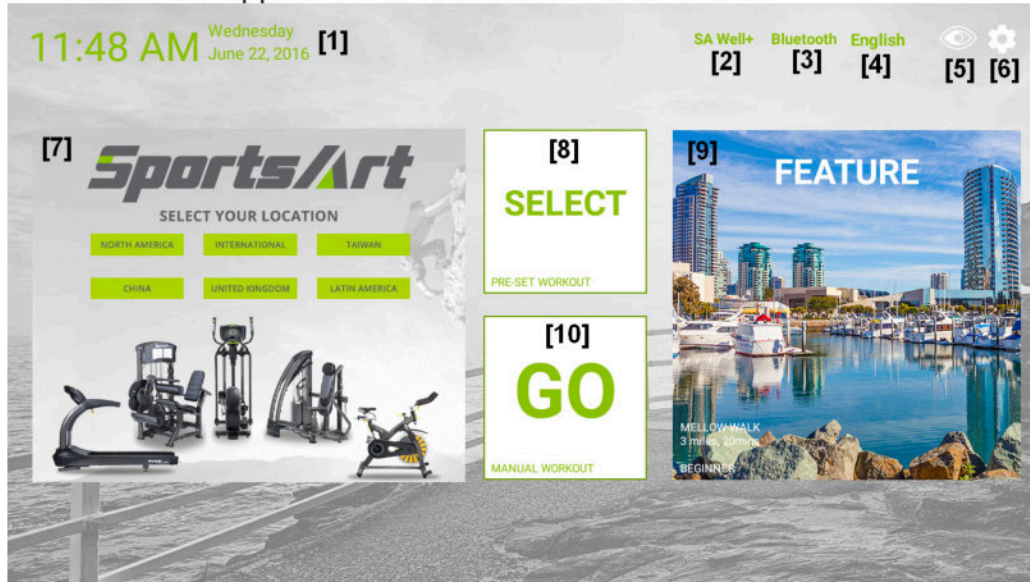

Description of start screen buttons:

No.	Name of button	Function
1	Date and Time	Displays the current time and date
2	SA WELL+	Touch to login into the SA WELL+ system
3	HR SELECT	Touch for pairing with Bluetooth or ANT+ heart rate strap
4	LANGUAGE SETTING	Touch to select your preferred language by country
5	DISPLAY MODE	Touch to switch screen to black and white display (with high contrast). Touch again, the screen will switch back to color display
6	ENGINEERING SETTING	Touch to access the engineering mode. This is the maintenance setting for use by technicians. Password input is required to perform the actions of the related settings
7	CUSTOMIZED WEB PAGE WINDOW	Web page status display for browsing and operation
8	SELECT	Touch this button to access workout program selection
9	FEATURE	Displays various virtual realities. Touch this screen to access the virtual reality training mode
10	GO	Touch this button to start workout

OPERATION Start your (GO) Workout

By using the (GO) workout, exercise is started in the manual workout mode. The default user age is 35 and default weight is 75 kg (165 lbs). You can proceed by using these default settings or change the settings.

How to start the (GO) workout:

1. Touch the (GO) button

A 3, 2, 1, GO countdown will appear on the screen, and the elliptical trainer will start.

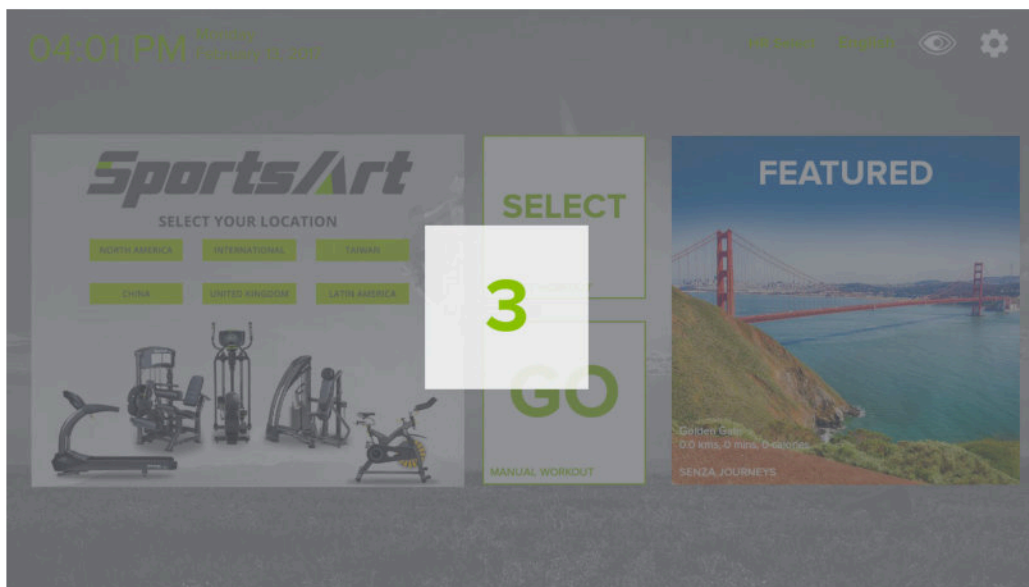

2. During the workout, if you choose to stop the workout, the “Workout Summary” screen will display the workout status for the session.

OPERATION Workout Selection

Tap on the Select icon to access “SELECT WORKOUT”.



1. If you are pedaling, the workout will start right after a 3 second countdown timer.
2. If you are not pedaling, you can pick the option that you want.

Select workouts on the screen:

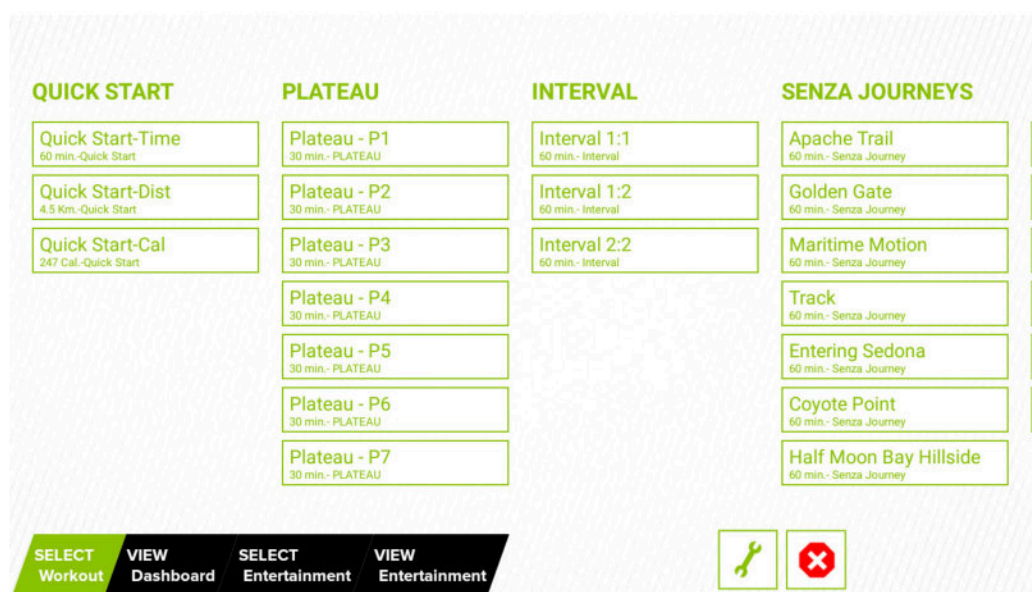
By swiping with your fingers, you can move between the workout options on the screen. The workout options are as follows: QUICK START, PLATEAU, INTERVAL, SENZA JOURNEYS, FAT BURN, VARI STRIDE, WATT, HEART RATE and FITNESS TEST. You can switch among these options while exercising.



Description of icons on the “Select” screen:

ICON	Description
	Tap to return startup screen. During exercising, tap it to stop or resume workout.
	Quick Tools

OPERATION Workout Programs

Workout program details are explained below.

Quick START

A workout mode option based on time, distance and calories that allows user to start a workout immediately.

PLATEAU

Various workout mode options are provided to achieve workout goal.

INTERVAL (1:1, 1:2, 2:2)

Interval Training is alternating periods of high intensity aerobic exercise and low intensity aerobic exercise.

Workout time ratios have 3 options, namely 1:1, 1:2 and 2:2.

SENZA JOURNEYS

Built-in or customized landscape films allow the user to watch a video of scenery while exercising.

FAT BURN

Various workout mode options are provided to achieve workout goal.

VARI STRIDE

This workout program automatically changes stride.

WATT

Various WATT modes are provided to help you achieve workout goal.

HEART RATE

A workout mode using heart rate as the target value.

FITNESS TEST

A variety of professional fitness test modes are provided, including the following programs:

- YMCA

OPERATION During Exercise

You can switch to different workout programs while exercising, with exception of the following condition:



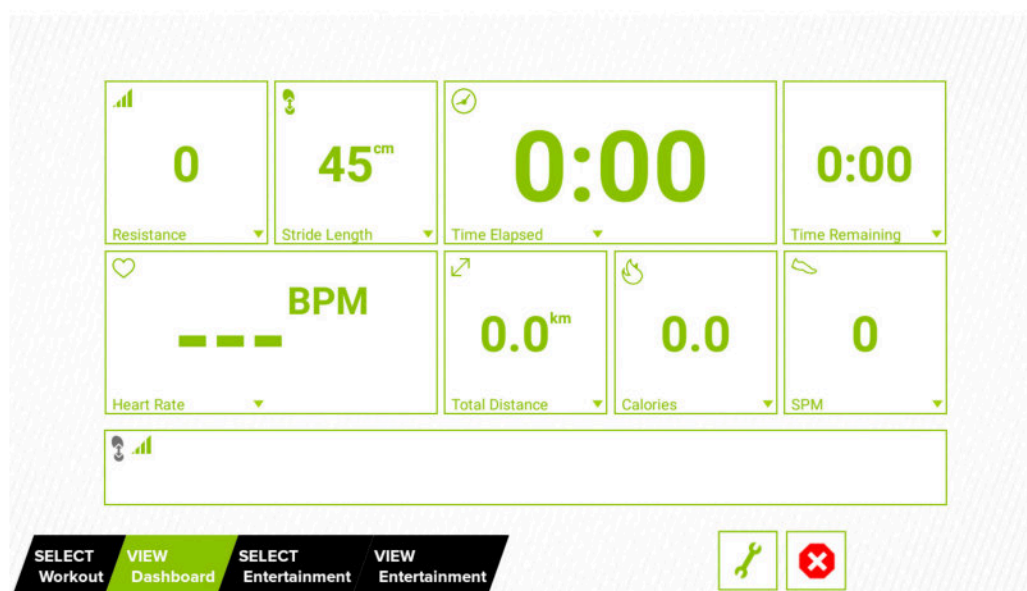

When you use QUICK START, FAT BURN, INTERVAL, SENZA JOURNEYS, PLATEAU, HEART RATE and FITNESS TEST, you cannot switch to WATT, and vice versa.

OPERATION Workout Status



During the workout, you can select the “VIEW Dashboard” page below the screen to check the exercise status of your workout process. There are a total of 9 status windows for various information views, and you can modify the information display format in the status windows by touching the ▼ symbol below the status windows. A drop down menu for information display format will be opened for selection.



Drop down menu introduction:

Symbol	Drop down Menu items	
	Default	Other Options
	Resistance	Average Resistance Watts Change Resistance
	Stride Length	Total Stride Speed Pace Average Speed Change Stride Length
	Time Elapsed	Time Remaining Clock Segment Duration Target Duration
	Segment Remaining	Segment Duration Time Elapsed Time Remaining
	Heart Rate	Average Heart Rate Max Heart Rate Set Target Heart Rate

OPERATION Workout Status (Continued)

Symbol	Drop down Menu items	
	Default	Other Options
	Total Distance	Distance Remaining
	Calories	Calories/Min Calories/Hour Mets
	SPM	Average SPM

OPERATION Select Entertainment

You can select the “Select Entertainment” page below the screen, and the available multimedia features will be displayed. The features include TV, Internet, SENZA Journeys, Bluetooth Audio, IPTV and AVIN, etc.: the small central window will display the selected multimedia screen immediately.

- Note: 1. At least 10Mbps Internet Speed is required in watching videos on YouTube or any other websites.
2. 10/100Mbps Base-T router is recommended for this product. If your router is 1000Mbps Base-T, ensure that the port is connected to the router at 10 Mbps or 100 Mbps.







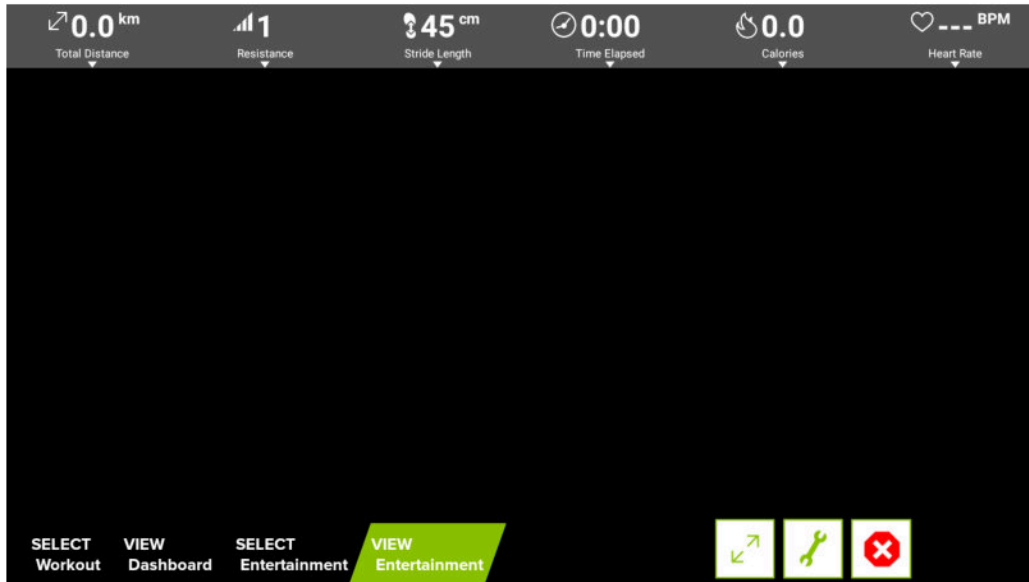

OPERATION View Entertainment

The console displays the media window in maximum frame size. If you want to check your workout status, simply tap the taskbar at the bottom of the screen. That way, you can evaluate your training status and adjust the workload accordingly.



Description of icons in the “Entertainment” screen:

ICON	Description
	Full Screen (Exit full screen mode by tapping screen.)
	Mute
	Lower volume
	Raise volume
	Slow reverse
	Play
	Fast Forward

OPERATION Workout Summary

At the end of a workout or when you press the stop button, the workout summary screen will appear. The screen shows your current workout status.



OPERATION Idle Mode

When the elliptical trainer stops running with no other activity for 2 minutes, the machine will enter the idle mode and the display will randomly show the standby picture. Touch anywhere on the screen to enter the Home page.

Note: The standby picture can be changed and set by the user.

OPERATION Energy Smart Function

There is a default Energy Smart timer setting feature in the engineering mode. When the elliptical trainer is not in use and the set up time for power saving is reached, the system will automatically enter the power saving mode, the Energy SMART light will change from green to orange, and the whole screen will turn dark. Press the Wake Up button to turn the power back on.

OPERATION Precautions

1. Turning the product on and off every day will make your software system refresh and stable and ensure waiting 5 minutes to turn on the product when you restart each time.
2. SanDisk USB (Fat32, MAX 32GB) is recommended for updating the program.

OPERATION SA WELL+

Tap SA WELL+ to enter SA WELL+ Login page.

First time user must create an user account with SA WELL+ App. After sign up, user information will be saved into the account.

Login to your SA Well+ account to track your workouts and will also allow you to download a created custom workout to machine.

There are two ways to login:

1. Without mobile device on hands, please manually enter SA WELL+ ID and password.
2. With mobile device on hands, please follow up below steps.
The instant information is shown on the cell phone.
 - 2-1. Open SA WELL+ APP
 - 2-2. Tap the " Scan QR code" button
 - 2-3. Scan QR code as instruction shown on your phone.

If your equipment is not equipped with SA WELL+, Login page will be shown as the following figure.

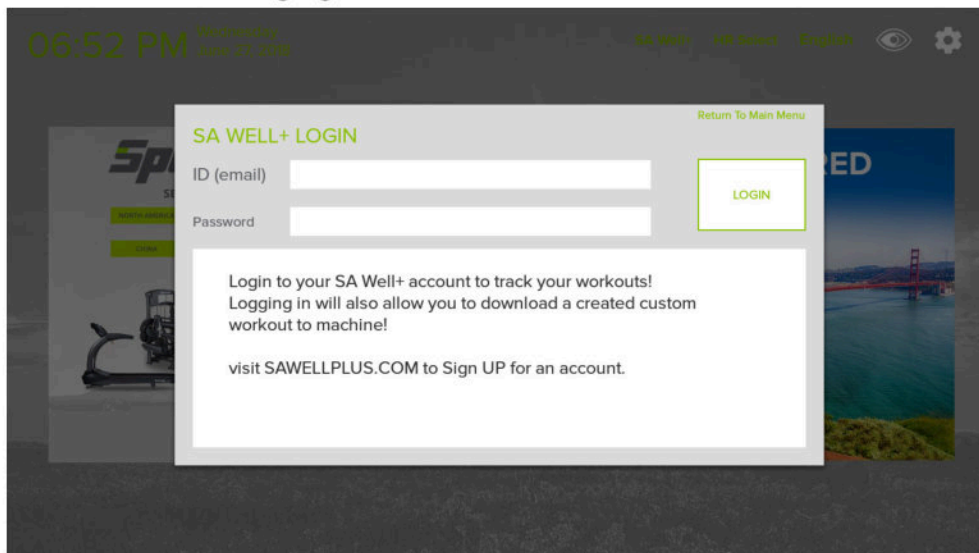

If your equipment is equipped with SA WELL+, Login page will be shown as the following figure.

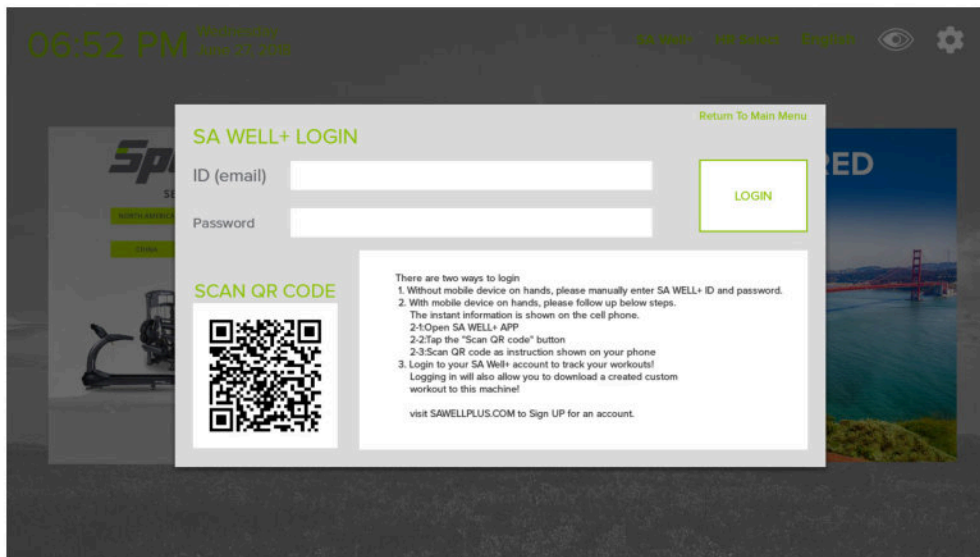

8. ABOUT HEART RATE DETECTION

Heart rate detection functions are selected at the time of purchase. Not every product has every type of heart rate detection. The following explains factors that influence the performance of two of the most common types of heart rate detection devices.

HEART RATE Telemetry

The words “telemetry heart rate” refer to the detection of heart rate via a device worn on the exerciser and transmitted over the air to a circuit board built into the product. Telemetry heart rate devices are commonly worn on the exerciser’s chest, where the pulse is strongest and relatively easy to detect.

The following explains conditions that affect the performance of the telemetry heart rate function in all products.

- The telemetry heart rate transmitter emits a wireless 5 kHz signal that is harmless to the human body. Keep a distance within 60cm between the heart rate receptor and the transmitter to achieve stable connection.
- If the battery is too low, the receiving distance may be shortened or there will be no reception.
- Secure the telemetry heart rate transmitter on your chest so that it stays in place without making you feel uncomfortable. Moisten the skin for better contact.
- Because the telemetry heart rate signal varies in strength from 20 Hz to 20 KHz, environmental interference can block signal reception. Physical vibration and electronic devices, including stereos, TVs, and even fluorescent lights, can interfere with signal reception. For best results, install the product in an area free from such interference.
- Space the product apart by at least 39 inches (100 cm) to avoid having the heart rate value from one exerciser appear on a neighboring product.

HEART RATE Contact

The words “contact heart rate” refer to the detection of the heart rate via sensors on the product. By holding the sensors, the exerciser can view his or her heart rate on the product display. Like telemetry heart rate, contact heart rate can be influenced by several factors. The following list includes some of these factors.

- A weak pulse makes it difficult to detect heart rate.

- Low systolic blood pressure makes it difficult to detect heart rate.
- Dry, course palms impede heart rate detection. For best results, moisten your palms. But do not apply hand lotion immediately prior to your workout, because hand lotion can gum up the contact pads.

Heart rate devices built into this product are not medical devices. Heart rate values are for reference only. Do not use them for medical diagnostic or treatment work.

CAUTION: Heart rate detection and transmission devices have been known to interfere with the operation of pacemakers, possibly endangering human life. If you have a pacemaker, exercise under your doctor's supervision; take a test to ensure your safety during the simultaneous use of the pacemaker and heart rate detection devices. The use of such devices must be undertaken at your own risk.

Note that in dry areas in particular, static electricity can build up on your body, and this can interfere with the operation and shock people. To discharge static electricity, touch something else before touching metal or other conductive objects.

9. GUIDELINES FOR EXERCISE

HOW HARD SHOULD I EXERCISE?

Studies show that to benefit from aerobic exercise, people should maintain a certain heart rate during their workouts. Your heart rate training zone is determined by your age and fitness level.

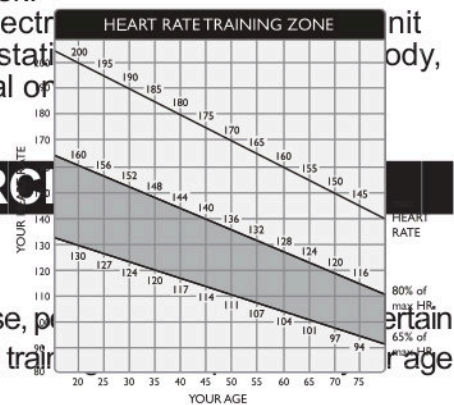

The darkened area in the chart to the right represents the recommended heart rate training zone for people of various ages. It was calculated by taking 220 minus age in years, multiplied by 65% and 80%. The area between those values is the heart rate training zone.

CAUTION: Heart rate training zones are generalizations and may not suit every person. Always check with your physician to understand what heart rate goal would be appropriate for you.

HOW LONG SHOULD I EXERCISE?

The duration of your workout must depend on your fitness level. In general, it is recommended that you maintain a heart rate within your training zone for at least 15 to 20 minutes to experience the benefits of aerobic exercise. Beginners should always start out slowly and gradually increase the duration and intensity of their workouts. As your fitness level improves, you will be able to maintain a heart rate within the training zone for longer periods of time.

When you begin your workout, use the first several minutes to warm up. Then slowly increase the intensity of your workout to bring your heart rate into your training zone.

At the end of your workout, gradually decrease your workload. Then exercise lightly to cool down.

HOW OFTEN SHOULD I EXERCISE?

Research indicates that to achieve the greatest benefit, people should exercise three to five times per week. It is important to allow sufficient time, at least 24 hours, for your body to recover after exercise.

10. MAINTENANCE

This section covers maintenance topics, including instructions on replacing a fuse and lubricating the walk belt, along with the presentation of a maintenance schedule, maintenance task list, one-year maintenance log, and electronics block diagram.

MAINTENANCE Safety Precautions

- Please follow standard safety precautions when servicing on this product.
- Electronic components can carry an electrical charge even after the product has been turned off. For safety, turn off unit power. Wait five minutes to allow capacitors to discharge. Then disconnect the power cord from the wall socket (if applicable.) Only after such steps have been completed should covers be removed and electronic components accessed.
- Unplug product and wait ten minutes before performing maintenance.
- Do NOT use a damp towel to clean the product and do perform the following maintenances.
- Do NOT use cleaners with alcohol, ammonia, or other damaging chemicals. The use of such chemicals can damage the product and void the warranty. Never spray or pour any liquid directly onto the product. Doing so can damage electronic components and void the warranty.
- Use a clean, lint-free towel, dampened with a mixture of Simple Green® all-purpose cleaner, to thoroughly clean the handlebar and the console.
- This product has moving parts that can be hazardous. Exercise caution when maintaining, operating, or moving this product.
- Do not use accessories or parts that are not specifically recommended by the manufacturer (SportsArt) . Such parts might cause injuries or cause

the unit to fail and void the warranty. We will not be responsible for any safety issue that arises due to the misuse of accessories or parts. At the same time, we will terminate the warranty terms of this equipment.

- The unit shall be disconnected from its power source during service and when replacing parts.
- Maintenance and repair must be performed by trained service personnel only. Improper maintenance would not only damage the machine, but also may present a danger to the exerciser.
- Keep this product out of use until maintenance is completed.
- If you need to remove the cover for repair or maintenance, be sure to contact the service station or dealer to deal with, do not operate on their own.

MAINTENANCE Error Messages

The following messages can appear on this product for diagnostic purposes.

ERROR 7 L, ERROR 7 R & ERROR 7 R/L - Indication: the stride mechanism is not calibrated properly. Contact a certified SportsArt technician. The technician will need to either inspect the stride motor or the driver.

ERROR _8_1, ERROR _8_2 - Indication: There is a communication error between control board and its driver. Contact a certified SportsArt technician. The technician will need to either inspect the stride motor or the driver.

Machine Model Unidentified - The machine model couldn't be identified.

MAINTENANCE Lubrication

To enter Lubrication function, first you must set the console to the Lubrication state. During Banner mode, the message shows "SELECT A PROGRAM", press STRIDE ▲ and STRIDE ▼ at the same time for 3 seconds to activate this procedure. Once Lubrication procedure is activated, the stride motor will move to the correct position and the message will display "LUBRICATION". At this time, it is ready for lubrication. Please follow the lubrication procedure listed on the following page to start lubricating. Once the lubrication procedure is completed, please follow below instruction to return the stride length to 29"/730mm.

1. When the power is off, pedaling the elliptical to turn on the power.
 2. Press and hold the STRIDE ▲ and STRIDE ▼ for 2 seconds to reset.
- The lubrication process is now completed.

MAINTENANCE Lubrication Procedure

- (a) Push in at point A, and slide upward to remove the lubrication cover.
- (b) Press the stride up key to adjust the stride to its longest point. Note the grease fitting at area B.
- (c) Use an automobile grease gun with red lithium grease. Apply the grease to the nozzle on the product.
- (d) Put the cover back into place, pushing inward at step 3 and downward at step 4, as shown below. Note that point A provides the best contact surface on the lubrication cover.

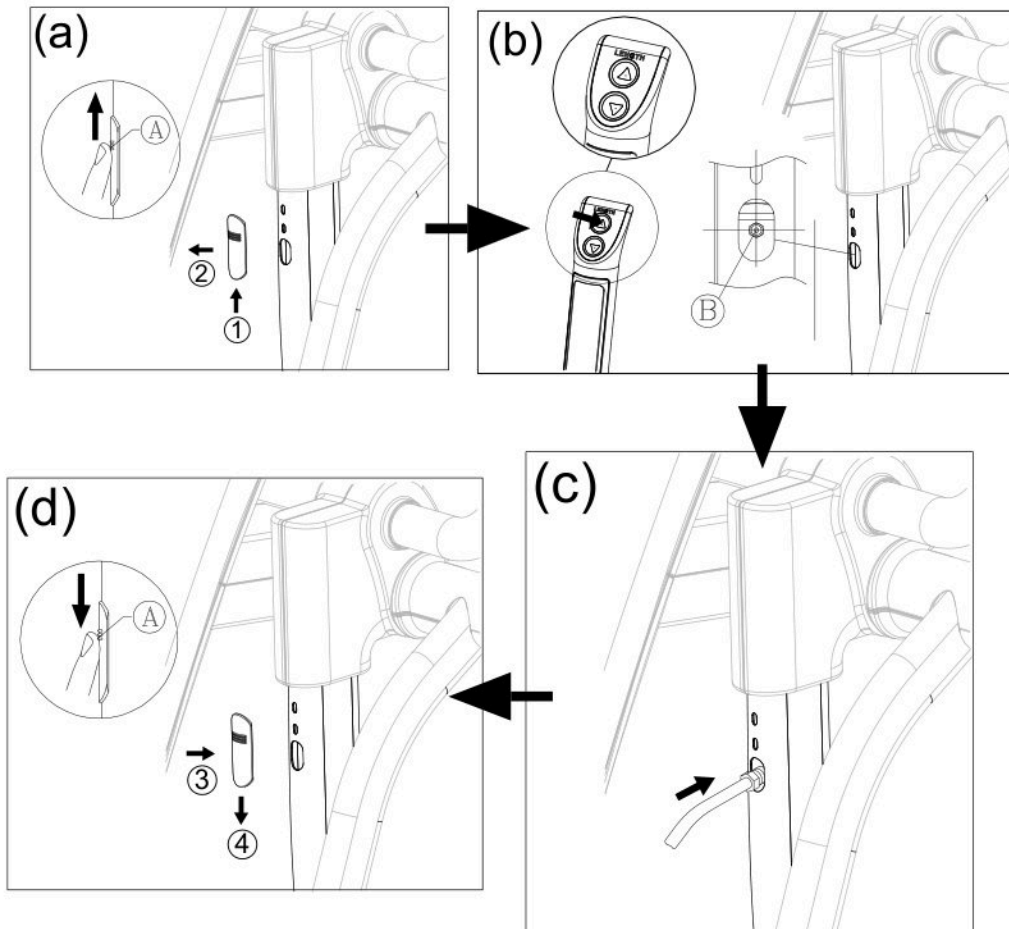

MAINTENANCE Cleaning the Glide Rails

Follow the steps below to clean left and right glide rails on a daily basis:

- (a) Use a clean, lint-free cloth to wipe dust and debris off the glide rails.
- (b) Test operate the product to determine where dirt might remain on the glide rails.
- (c) Repeat steps (a) and (b) two or three times to ensure smooth movement.

(Note: make sure to use a lint-free cloth)

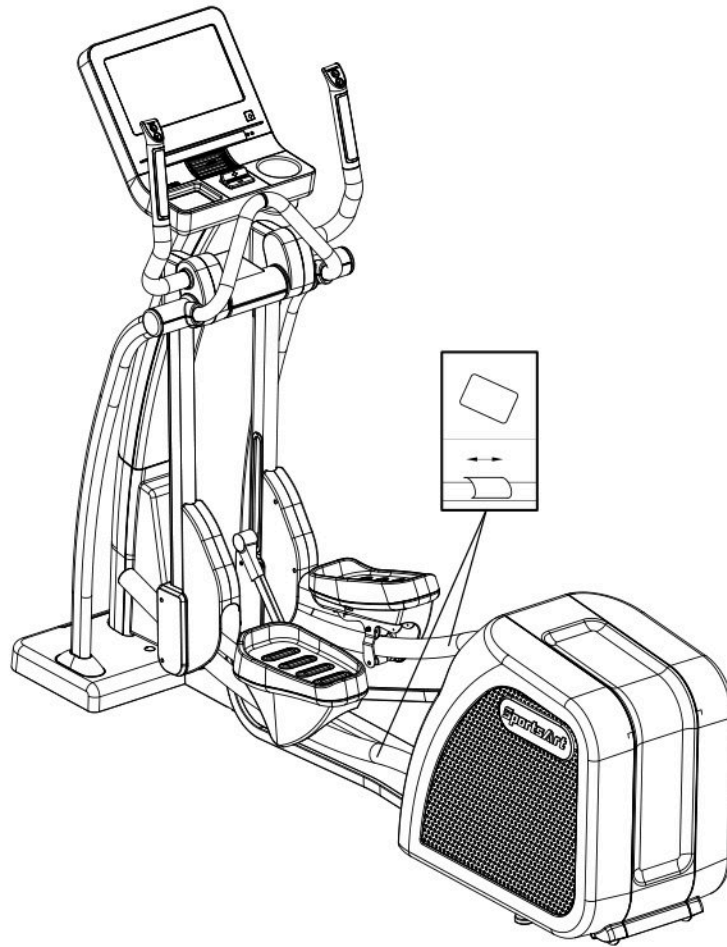

MAINTENANCE Schedule

	Area	Day	Week	Month	Quarter	Year	Notes
1	Exterior	•					Clean.
2	Screws	•					Inspect and secure loose parts
3	Glide rail	•					Wipe away dirt and debris.

4	Rollers		•				Apply silicone lubricant..
5	Stride motor					•	Apply bearing grease
6	Cushion					•	Lubricate with original 66A lubricant.

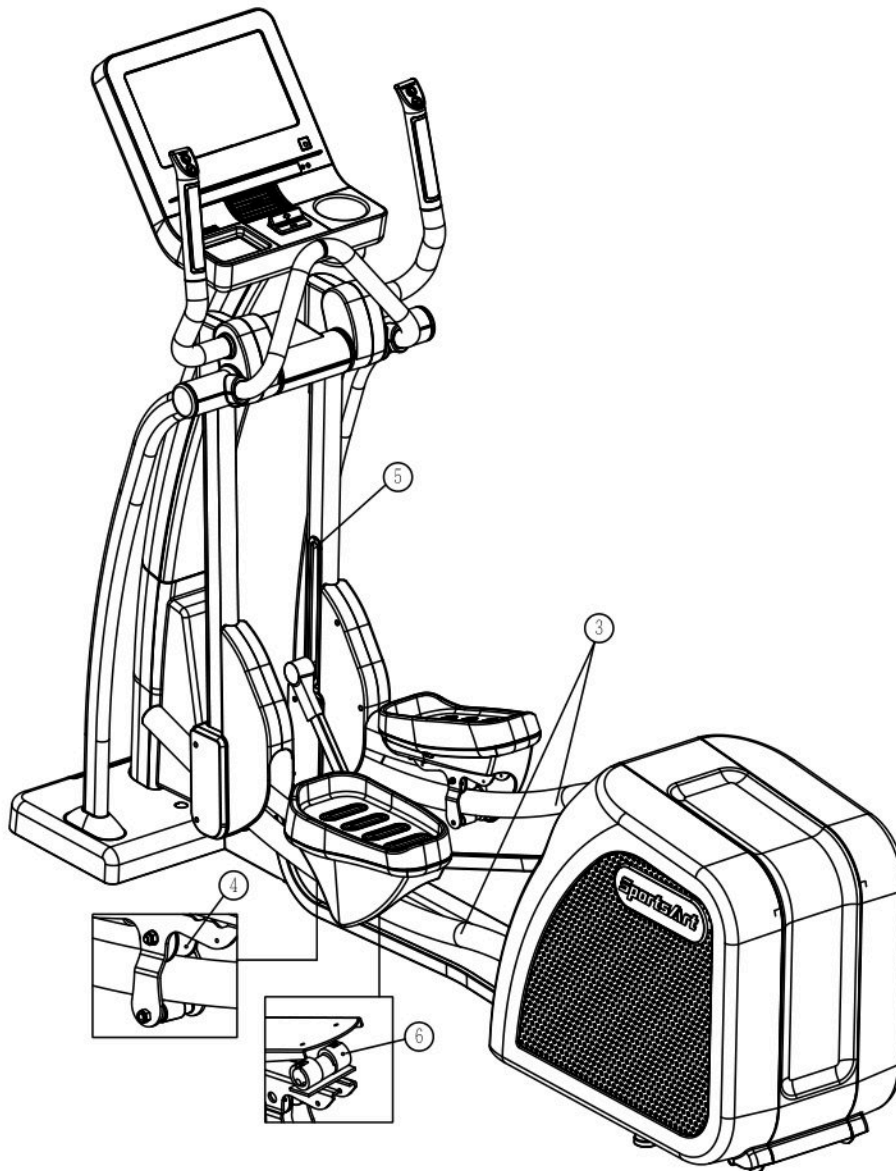

11. ACCESSORIES

ACCESSORIES Standard

USB CHARGER

The USB charger will provide 5V and 1.5A voltage for charging of smart phone or other devices. However it is compatible only with some tablets, such as iPad. Check your tablet for compatibility before charging.

CSAFE PORT

Compatible with CSAFE (Communications Specification for Fitness Equipment) Protocol.

To support MYE Wireless TV Audio_Channel Receiver, and the other equipment that conform to the CSAFE specification.

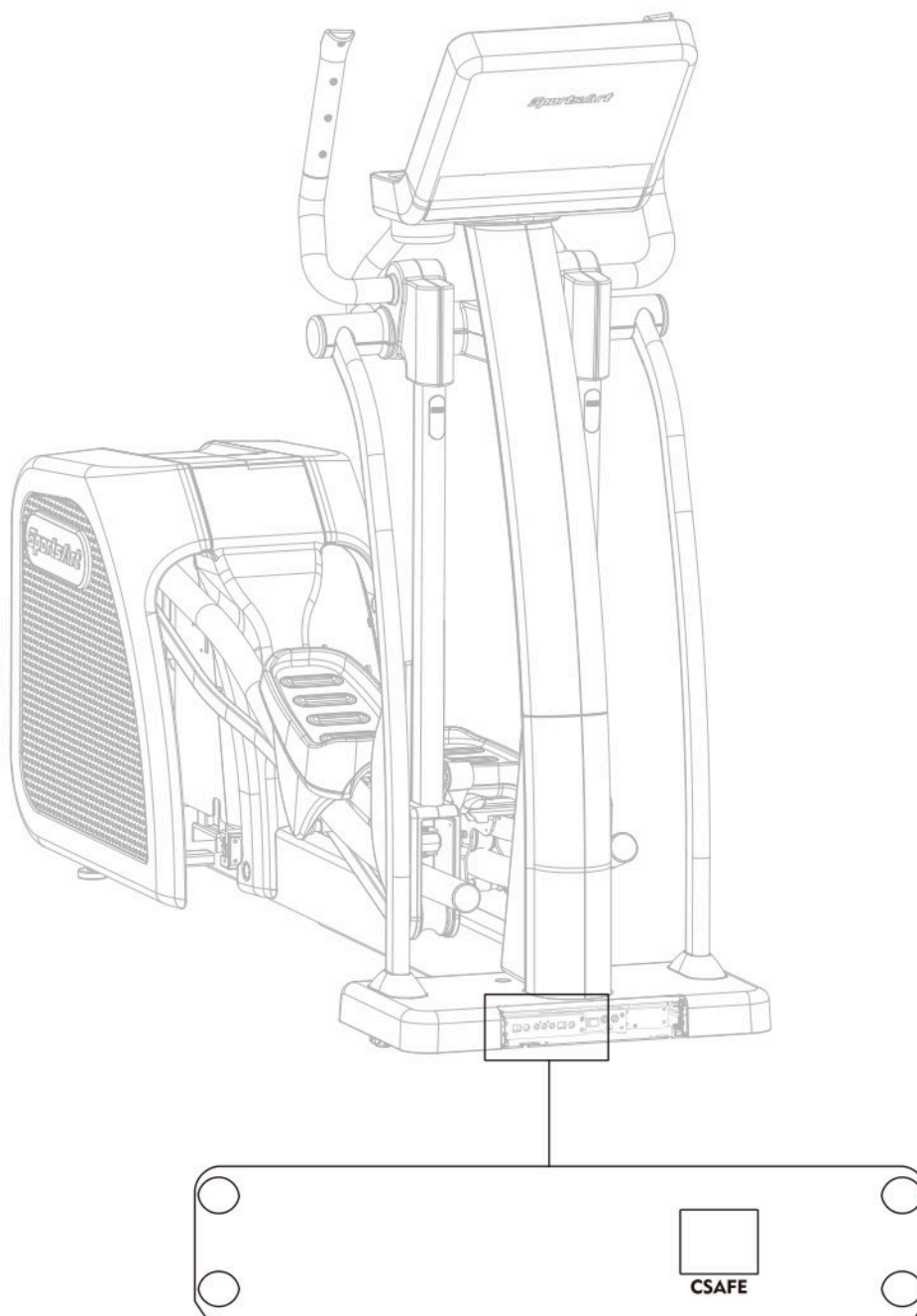

ACCESSORIES Option

SA WELL+ Member System

This is designed specially by SportsArt to assist the user in managing their workout history. There are three ways to get connected with the member site:

1. Using a smartphone, connect to the unit via Bluetooth/WIFI and use the SA WELL+ App. The App is available for download in the App Store and Google Play.

2. Use USB Flash Drive to store the workout data.
3. Manage user information and workout data

Visit “www.gosportsart.com” for more information about this feature.



No.	Name of button	Function
a	USB port	This port is used for optional data transferring.
b	Bluetooth/WIFI button	When a smart phone is connected wirelessly to the unit, press this button to disconnect. Scan the QR code or tap the NFC tag on the console to connect to the equipment again.

ACCESSORIES MYE Wireless TV Audio_Channel Receivers

[To purchase, please contact MYE Inc. <http://www.myclubtv.com/>]

Multiple TV and audio channels receiving and volume adjustment enabled.

- The following two modules are available for this receiver (to be purchased by client):
1. MC3R-9(900MHZ), which has to be used with a MYE Wireless TV Digital Audio Channel Transmitter MWTD-S9.
 2. MC3R-8(863MHZ), which has to be used with a MYE Wireless TV

Digital Audio Channel transmitter MWTD-S8.

Choose a suitable module according to country of location. (Please contact

MYE Inc. for detail specification and technical information)

For example: Wireless TV transmission frequency in America is 900MHZ.

Wireless TV transmission frequency in Europe is mostly 863MHZ (or nominally 800MHZ).

- Operation instruction: Turn off unit power, plug the receiver into the CSAFE port located at left of display and then turn on the power.
- The VOLUME +/- keys and CHANNEL ▲/▼ keys will be activated once the receiver is plug into the unit.

Press VOLUME +/- keys to adjust volume settings. The volume setting range is from 0 to 15, with a default setting of 5.

Press CHANNEL ▲/▼ keys to change channel settings. The channel set

ting range is from 1 to 32, with a default setting of 1. The display will show

“CH XX” during setting.

- Note: Do not unplug the receiver from unit before turning off the power to avoid receiver being damaged.
- The following is a schematic diagram of the connection:

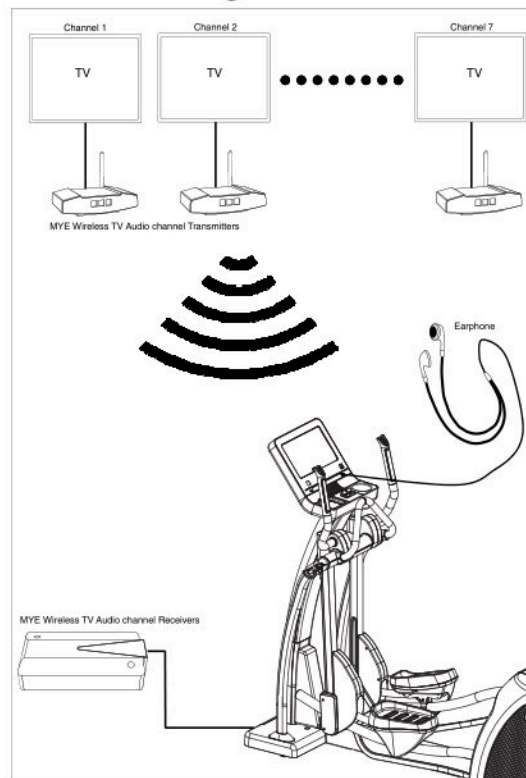

12. APPENDIXES

APPENDIX Specifications

Model	E876 16"
-------	----------

Dimensions	L : 2222 mm (87.5") W : 670 mm (26.4") H : 1750 mm (69")
Overall Weight	186 kg (410 lbs)
Maximum User Weight	150 kg (330 lbs)
Power Requirement	100 – 120 V / 60 Hz (USA) 220 – 240 V / 50 Hz (EUROPE)
Circuit Breaker Current Rating	110 V : 2A 220 V : 2A
Braking System	Speed-Independent

APPENDIX Electronics Block Diagram

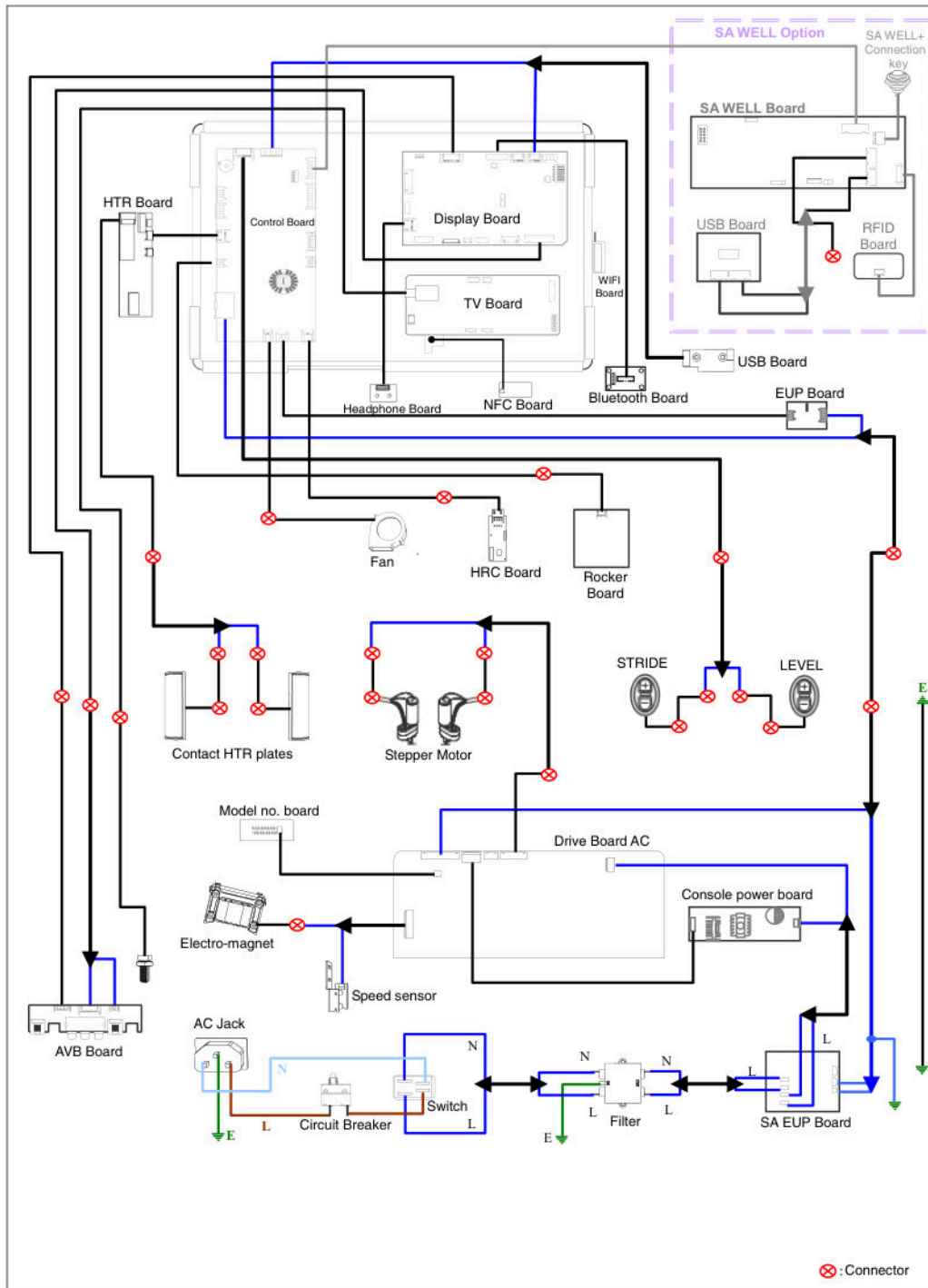

APPENDIX Exploded Diagrams

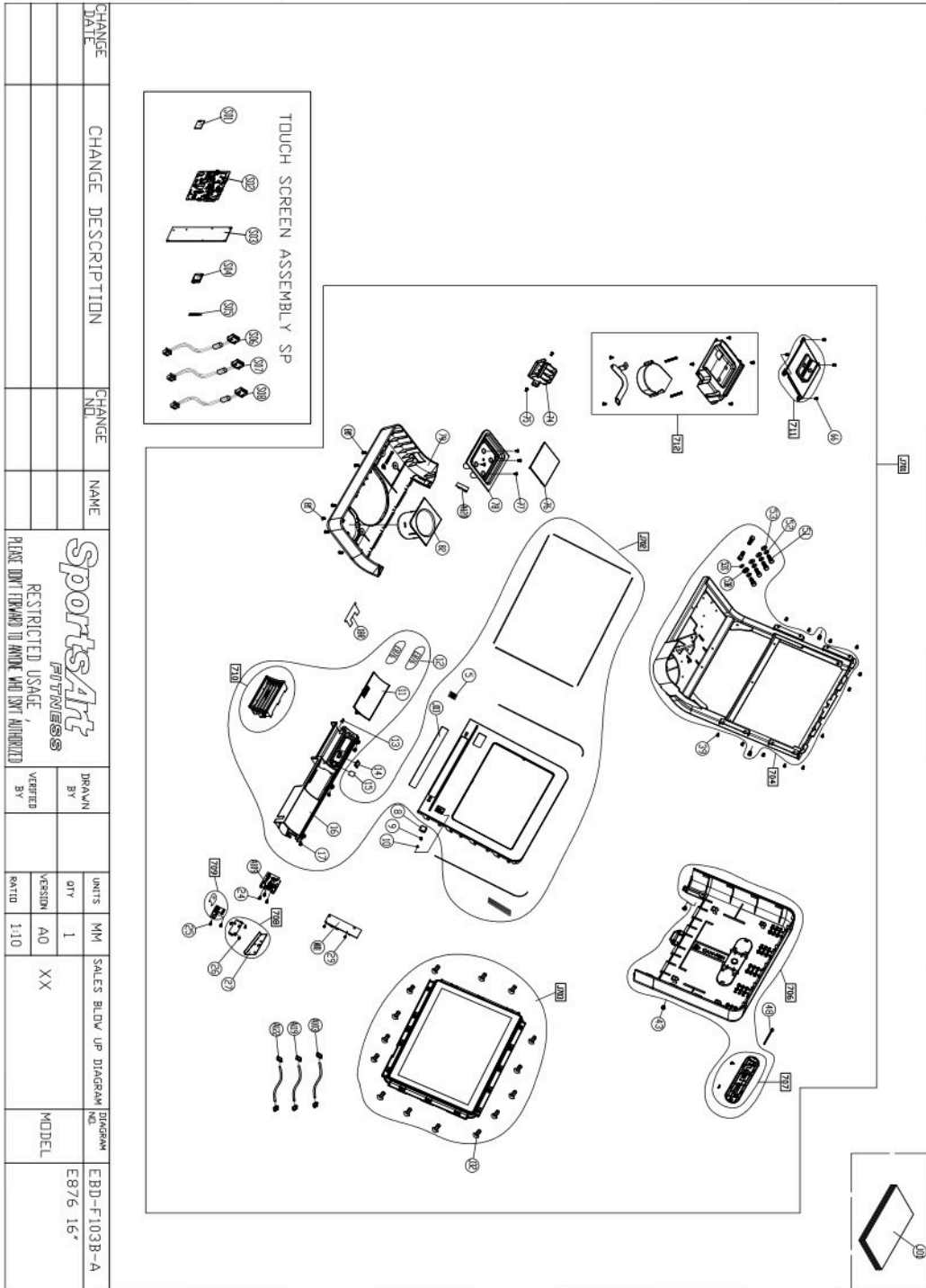

CHANGE DATE	CHANGE DESCRIPTION	CHANGE NO.	NAME	DRAWN BY	UNITS QTY	MM	SALES BLDW UP	Diagram No.
			SportsArt FITTINGS		1			EBD-F103B-A
			RESTRICTED USAGE, PLEASE OBTAIN PERMISSION FROM ANHONG	VERIFIED BY	AD	XX		MODEL
					1:10			EB876-16"

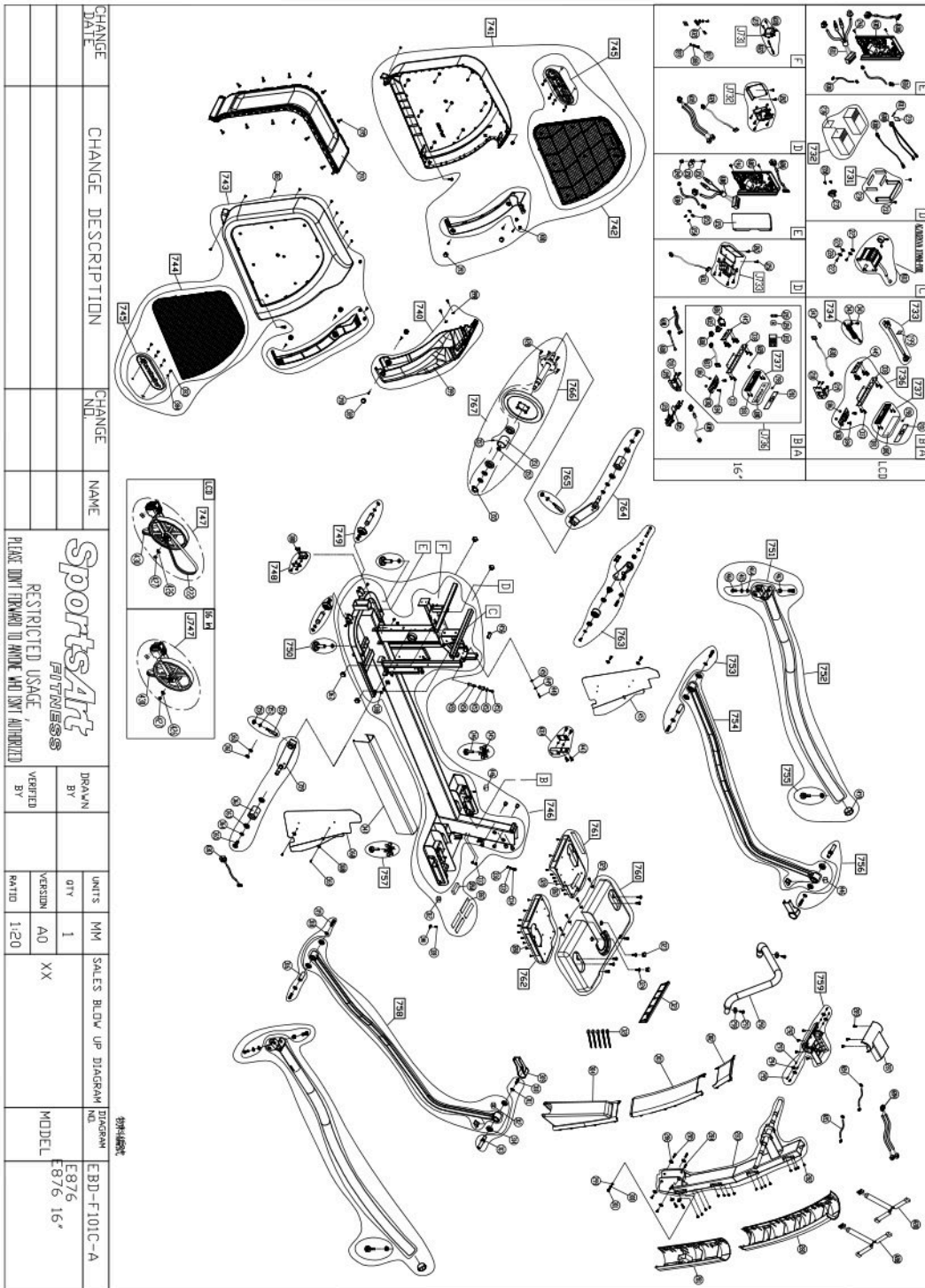

CHANGE DATE	CHANGE DESCRIPTION	CHANGE NO.	NAME	UNITS	MM	SALES BLDG UP DIAGRAM NO.	DIAGRAM
				QTY	1		EBD-F101C-A
				VERSION	A0	XX	MODEL
				RATIO	1:20		E876 16"
				DRAWN BY VERIFIED BY PLEASE PRINT FORWARD TO PROVE AND DON'T AUTHORIZE			
RESTRICTED USAGE, SPORTSART							

APPENDIX Disassembly

(a) Main Frame

- (b)Lift Motor Assembly
- (c)Front Base Cover

