

N919 OWNER'S MANUAL CONTENTS

1. INTRODUCTION	2
2. SAFETY PRECAUTIONS	3
3. LIST OF PARTS	4
4. ASSEMBLE THE PRODUCT	6
STEP 1 Install the Main Frame	6
STEP 2 Install the Belt	7
STEP 3 Install the Foot Rest	8
STEP 4 Install the Weight Stack Covers	9
STEP 5 Install the Cap Nut	10
STEP 6 Secure the Unit	11
STEP 7 Seat Adjustment Instructions	12
STEP 8 Belt Tension Adjustment Instructions	13
STEP 9 Unit Inspection	14
5. OPERATE THE PRODUCT	15
OPERATION Safety Operating Area	15
OPERATION Exercising Instructions	16
6. MAINTENANCE	17
MAINTENANCE Safety Precautions	17
MAINTENANCE Guide Rod Cleaning and Lubricating	18
MAINTENANCE Important Note	19
MAINTENANCE Schedule	20
MAINTENANCE Task List	21
MAINTENANCE Maintenance Log	22
7. CONSIGNES DE SÉCURITÉ IMPORTANTES	23
8. APPENDIXES	24
APPENDIXES Exploded Diagram	24

1. INTRODUCTION

Congratulations on the purchase of a high quality SportsArt product, the N919 Independent Lateral Raise machine. Constructed of high quality materials and designed for years of reliable performance, this product was made for full commercial use.

Before this product is assembled or operated, we recommend that you familiarize yourself with this manual. Understanding the correct assembly and operation of this product will help ensure that exercisers obtain their fitness goals safely and successfully.

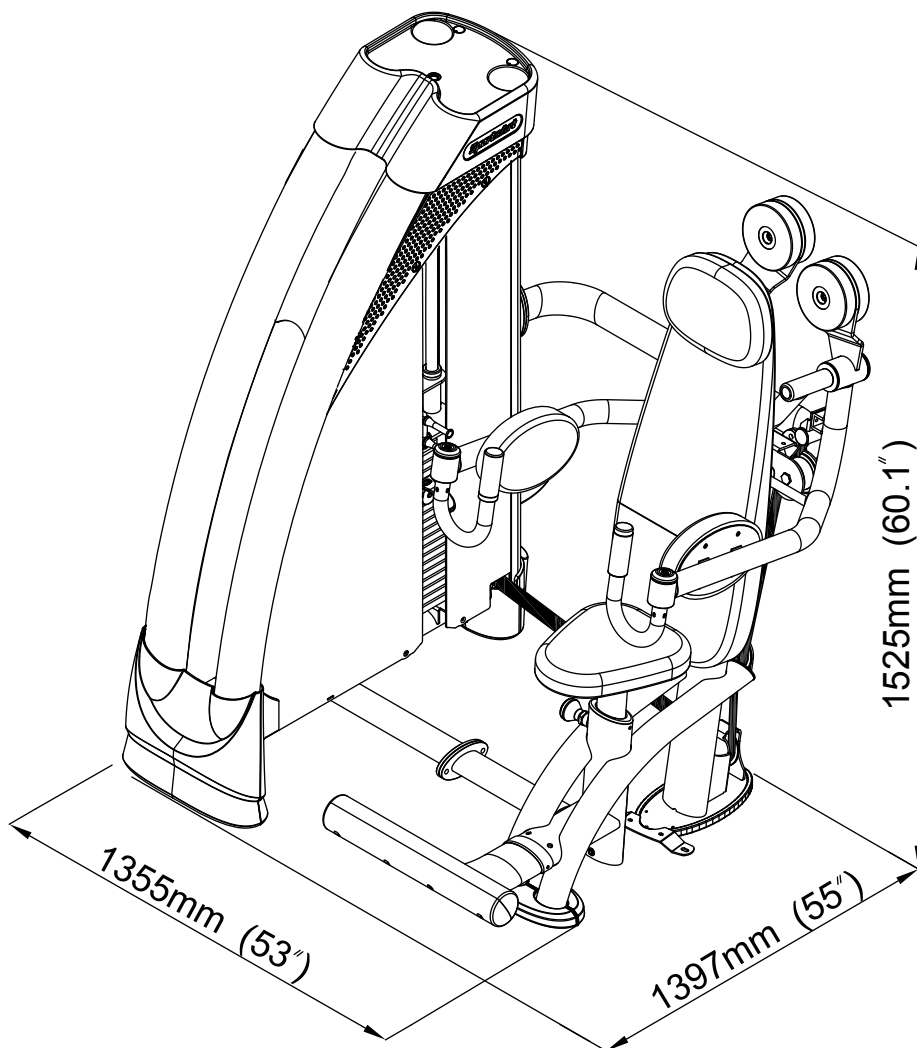

2. SAFETY PRECAUTIONS

This product was designed and built for optimum safety. However certain precautions apply during the use of this product. Please note the following safety precautions:

- Please read the entire manual before assembly and operation. Make sure the product is installed and operated as instructed in this manual.
- Assemble and operate the product on a solid, level surface. Do not use outdoors or near water, including pools and saunas.
- Check the product before every use. Make sure all parts are assembled, and all fasteners are tightened. Do not use the product if it is disassembled in any way.
- Wear proper workout clothing. Do not wear loose clothing. Do not wear shoes with leather soles or high heels. Tie all long hair back. Do not go barefoot on this product.
- Keep away from moving parts. Moving parts may or may not stop immediately if an object becomes caught or impedes normal motion.
- Use this product only for its intended purpose as described in this manual.
- Be careful when mounting and dismounting the unit.
- Never operate this product if it has been damaged in any way. If it is not working properly, or has been dropped or damaged, contact a service technician for repairs.
- Do not use accessories or parts that are not specifically recommended by the manufacturer (SportsArt) . Such parts might cause injuries or cause the unit to fail and void the warranty. We will not be responsible for any safety issue that arises due to the misuse of accessories or parts. At the same time, we will terminate the warranty terms of this equipment.
- This product is not intended for use by persons (including children 12 or younger) with reduced physical, sensory, or mental capabilities, or by people who are otherwise deficient in product knowledge or experience. If such people use this product, they should be given training and be supervised at all times by someone responsible for their safety.
- Children ages 12 or younger should be supervised to ensure that they do not play on or near the product.
- Maintenance and repair must be performed by trained service personnel only. Improper maintenance would not only damage the machine, but also may present a danger to the exerciser.
- The user weight limit for this product is 227 kg (500 lb).
- Warning that any of the adjustment devices that could interfere with the user's movement should not be left projecting.

CAUTION: If you feel any pain or any abnormal sensations, STOP YOUR WORKOUT and consult your physician immediately. Work within your recommended exercise level. DO NOT work to exhaustion. Before beginning any exercise program, you should consult with your doctor. It is recommended that you undergo a complete physical examination.

Over exercise may result in serious injury or death. If you feel faint, stop exercising immediately.

*NOTE: Each machine provides a different resistance ratio of weight stack.

3. LIST OF PARTS

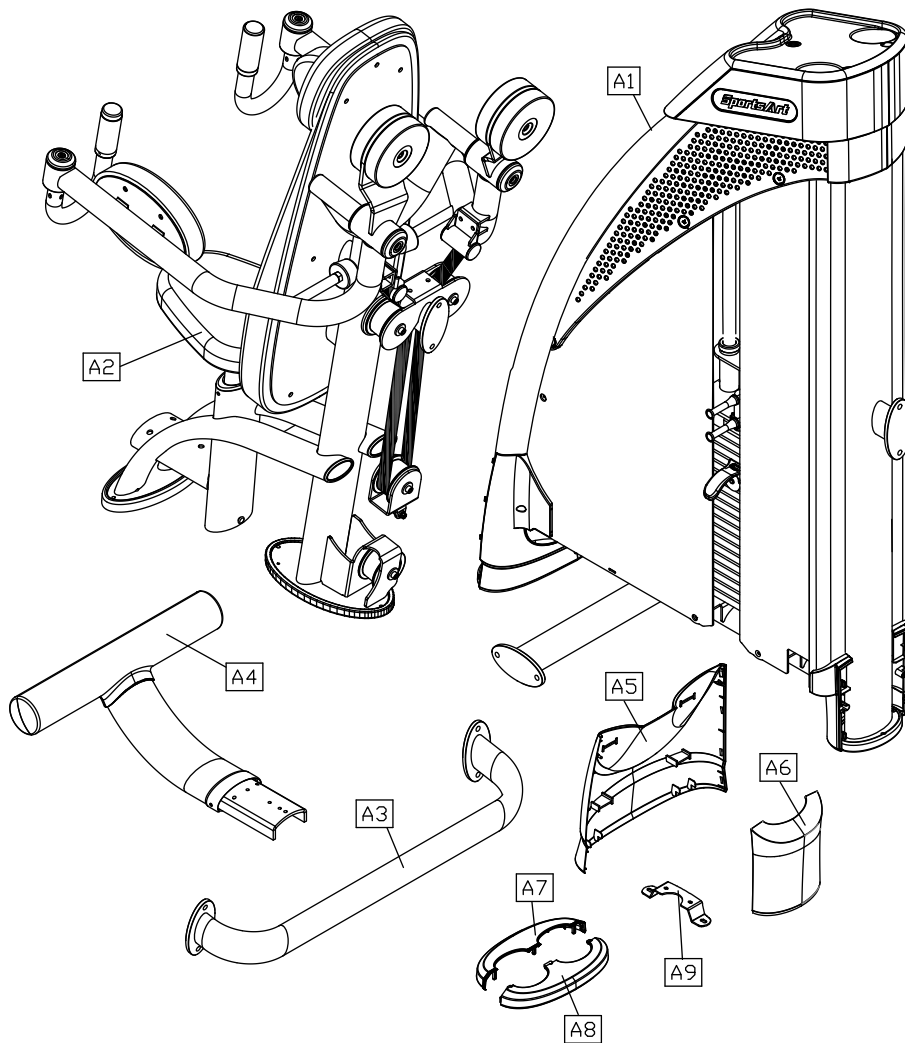

Assembly Parts					
No.	Name	Qty.	No.	Name	Qty.
A1	Weight Stack Frame	1	A6	Weight Stack Rear Cover	1
A2	Seat Frame	1	A7	Dual 80 Oval Foot Cover A	1
A3	Connecting Tube	1	A8	Dual 80 Oval Foot Cover B	1
A4	Foot Rest	1	A9	Ground Fixing Bracket	1
A5	Weight Stack Front Cover	1			

Components In the Hardware Kit				
No.	Name	Qty.	Specification	Notes
10	Push rivets	2		
	L-shaped Allen wrench	1	(M5)	
	L-shaped Allen wrench	1	(M6)	
	Double open-end wrench	1	(8*17)	
	Double open-end wrench	1	(8*10)	
	Double open-end wrench	1	(12*15)	
	Double open-end wrench	1	(17*23)	
19	Cap nut			

Components on the Product			
No.	Name	Specification	Notes
20	Hex screw	M10*P1.5*L35	
	Spring washer	M10	
	Flat washer	D16*d10.2*t1.0	
	Nylon hex nut	M10*P1.5	
21	Pin	D8*L50	
	Flat washer	D15*d6.5*t3.0	
	Spring washer	M6	
	Nylon hex nut	M6*P1.0*6	
22	Mushroom head inner hex screw	M8*P1.25*L25	
	Spring washer	M8	
	Flat washer	D17*d8.3*t2	

4. ASSEMBLE THE PRODUCT

Follow instructions below to assemble this product. Note that in this manual the words “left” and “right” are used to refer to the product and its parts. As such, these designations correspond to the “left” and “right” sides of a person in position to exercise on this product. Also, for brevity, the word “screws” or “nuts” is used where washers and other hardware may be involved.

STEP 1 Install the Main Frame

Due to safety concerns, a minimum of 3 people are required for assembly of the equipment.

- (a) Remove screws (20) from the weight stack frame (A1).
- (b) First, have one person stand at the back of the equipment and hold the weight stack frame (A1), then secure the connecting tube (A3) to the weight stack frame (A1) using screws (20), after that, secure the seat frame (A2) to the weight stack frame (A1) and the connecting tube (A3) using screws (20).

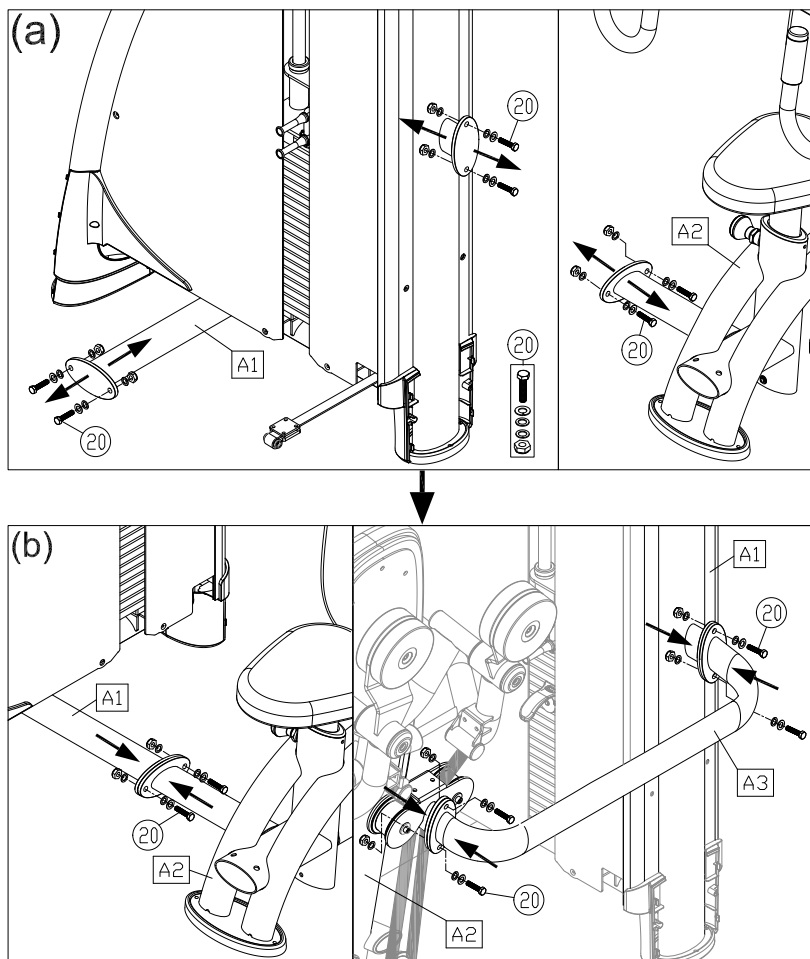

STEP 2 Install the Belt

- (a) Remove the pin (21) from the pulley, and then secure the belt onto the pulley with pin (21).

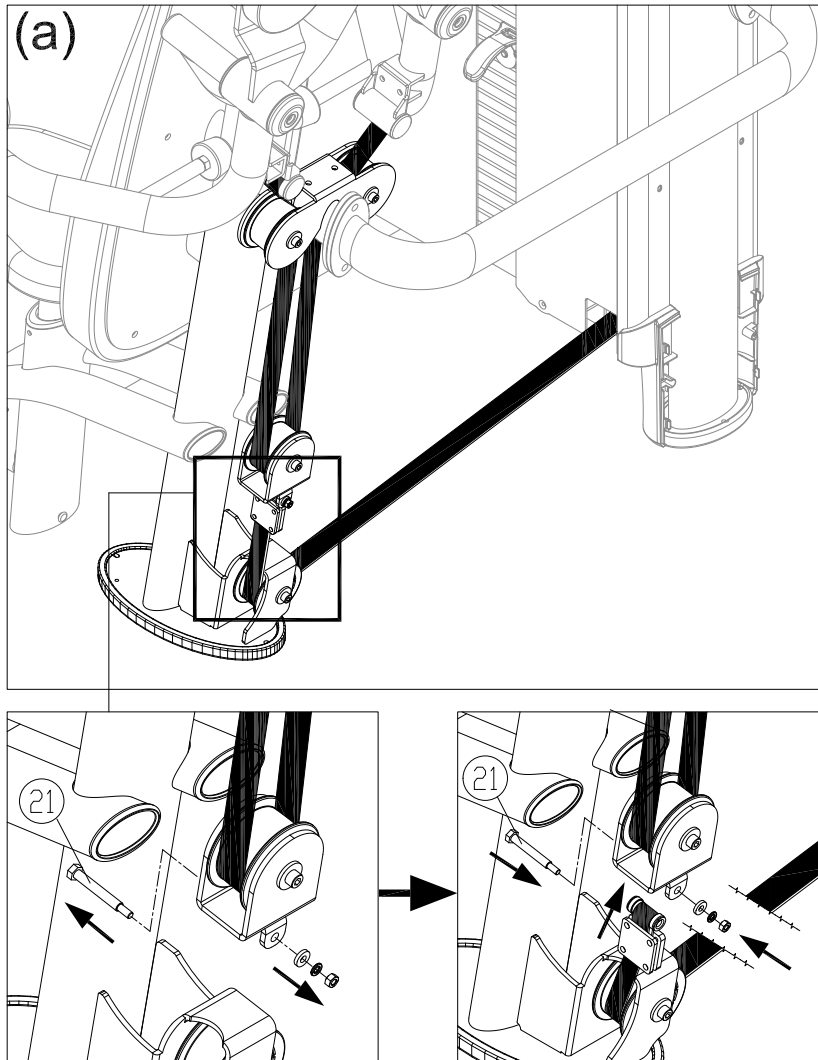

STEP 3 Install the Foot Rest

- (a) Remove screws (22) from the foot rest (A4).
- (b) Attach the foot rest (A4) onto the seat frame (A2), then secure the assembly with screws (22).

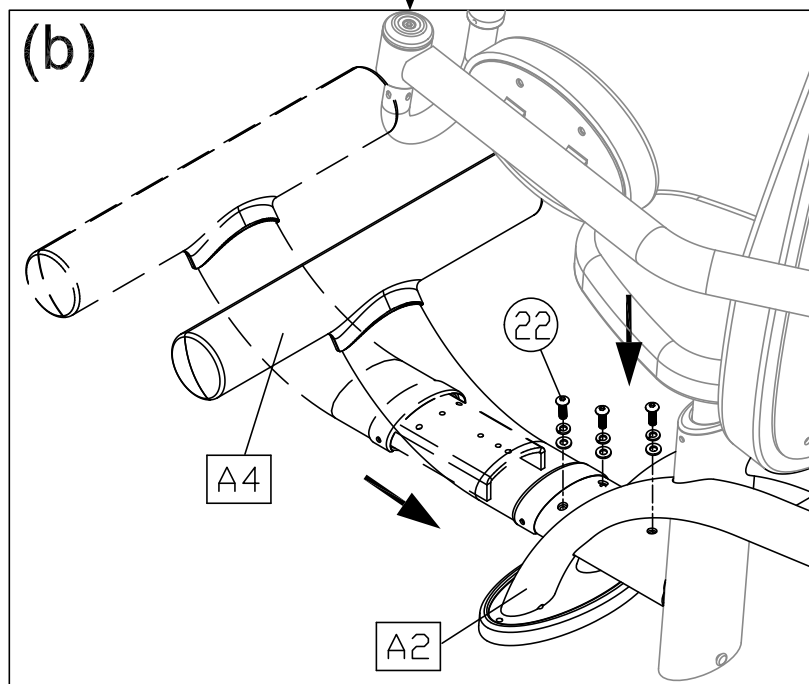
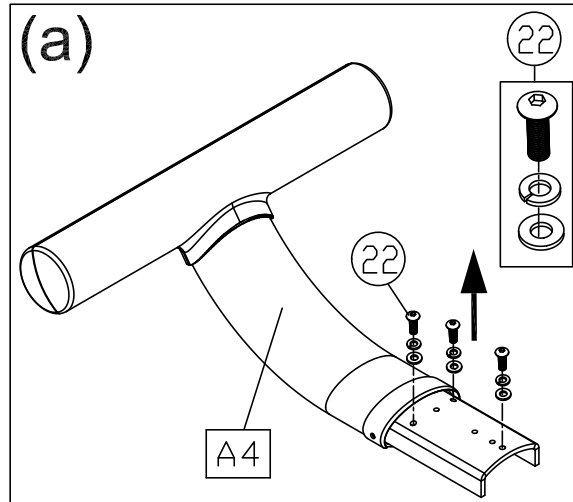

STEP 4 Install the Weight Stack Covers

(a) Attach both front and rear weight stack covers (A5)(A6) onto the weight stack frame (A1). (Note: before attaching the front weight stack cover (A5), make sure the inside hanger is hooked to the frame before securing it to the weight stack frame.)

(a) Attach the oval foot covers (A7) (A8) onto the the seat frame (A2) legs. Align the ends and using push rivets (10) to secure the foot covers together.

Note: If the holes don't match up while installing the oval foot covers, change their direction and put them back in a new way. The cutout should face the inner side of the foot tube.

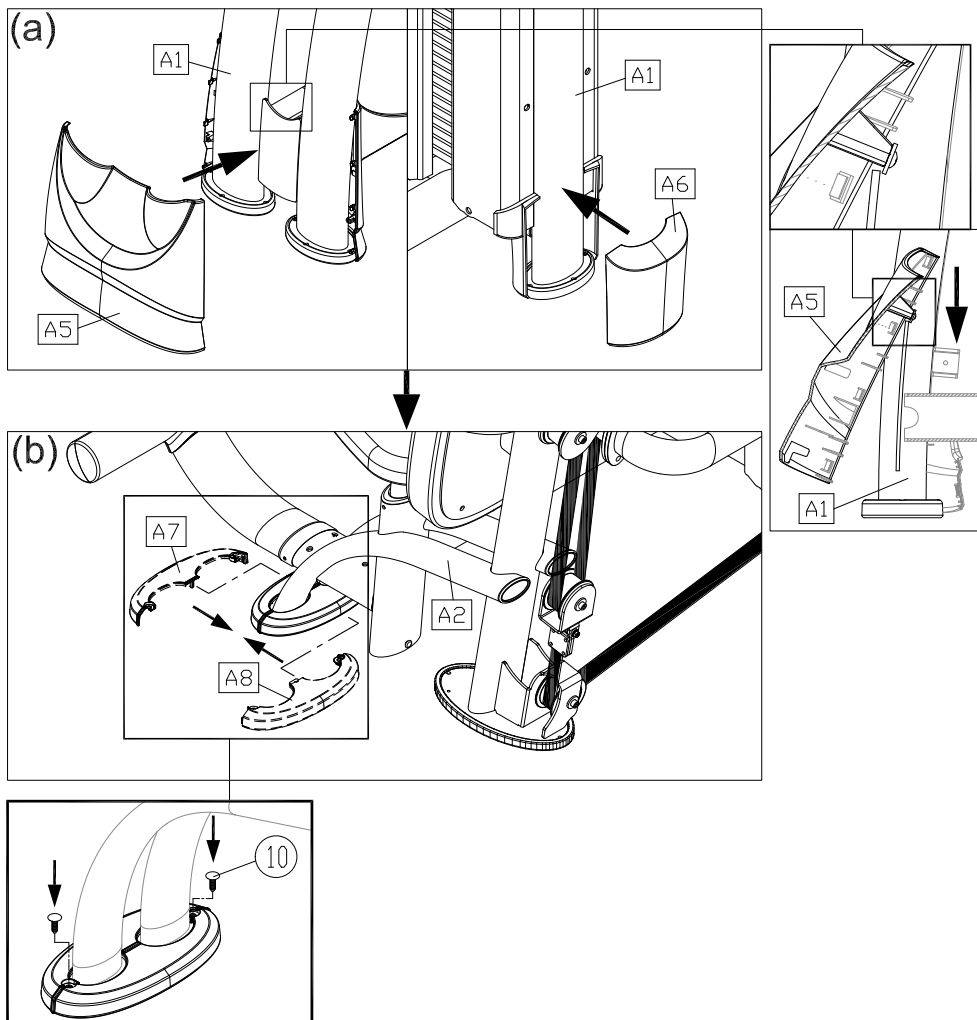

STEP 5 Install the Cap Nut

After completing the assembly, install the cap nut (19) as shown in the following figure.

Note: Make sure the cap nuts and screws are size-matching.

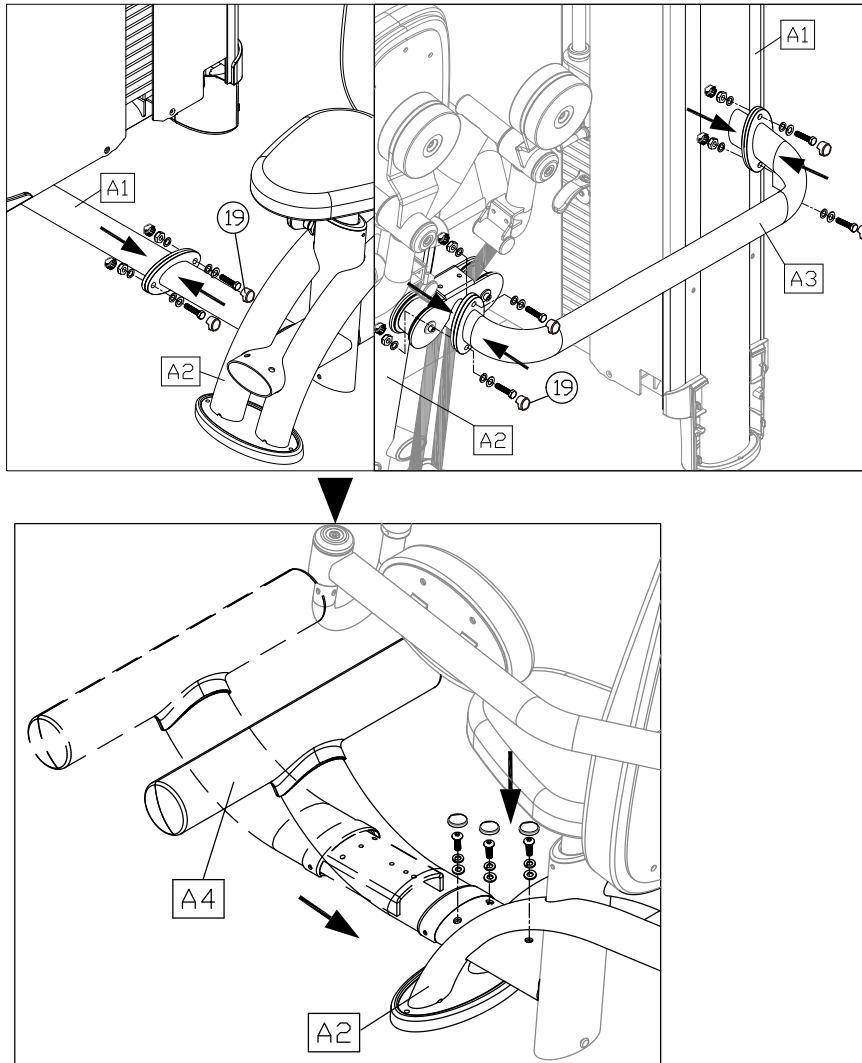

STEP 6 Secure the Unit

Secure the ground fixing bracket to the floor with the ground fixing bolt, nut and washer, and make sure the unit is firmly fixed to the floor when operating.
Note: The screw hole of ground fixing bracket is $\text{\O}9\text{mm}$, make certain you use the suitable ground fixing bolt and drill the proper hole on the floor.

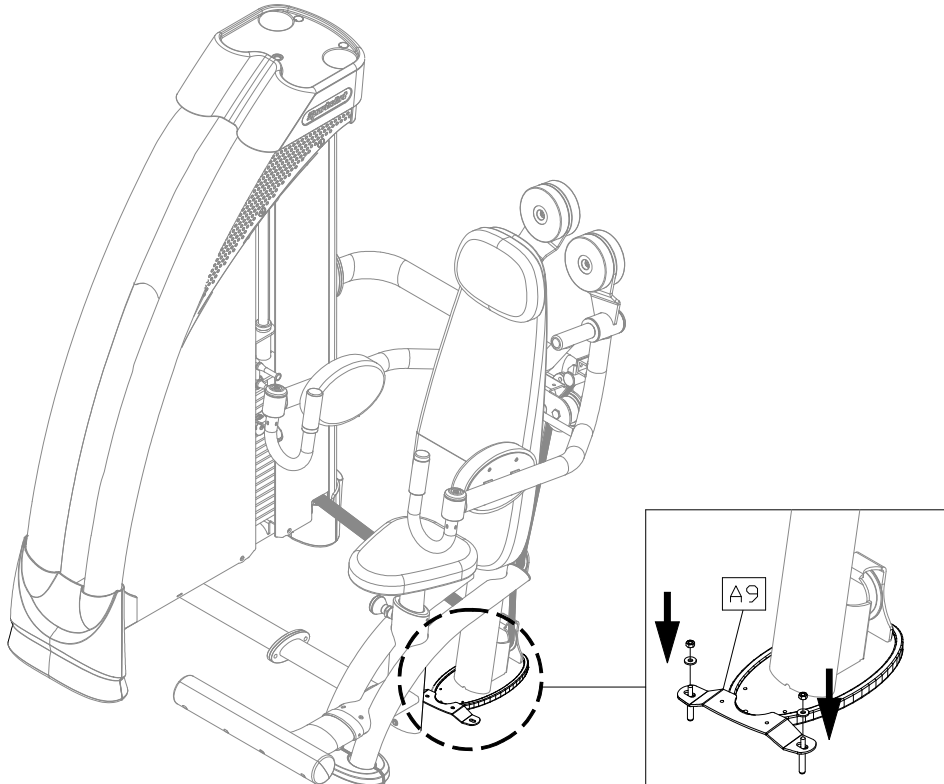

STEP 7 Seat Adjustment Instructions

- * When adjusting the seat height, pull out the seat lever and use the lever to adjust the seat height. Once the seat is properly adjusted for your height, lock and secure the seat lever in place.
- * If the seat has not been used for a long time, or the height adjuster moves unsmoothly, try pressing and holding down the seat several times before adjusting seat height.

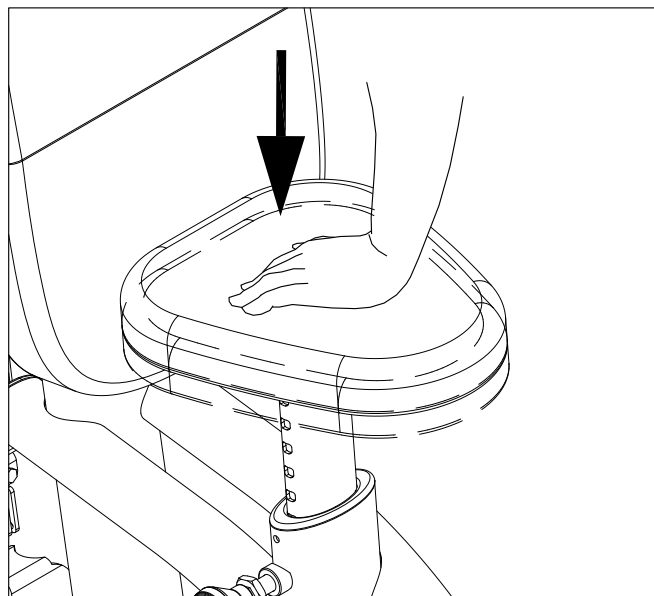
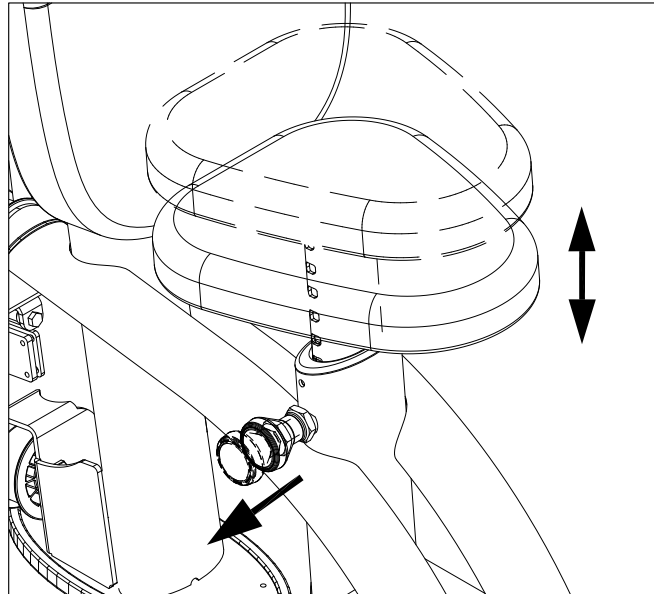

STEP 8 Belt Tension Adjustment Instructions

1. After finishing installation and the final positioning of the equipment, perform the whole-machine-test to ensure it works properly.
2. If the belt tension is incorrect, perform the modification adjustment: First loosen nut A then adjust nut B (as shown in the figure).
Note that if the belt is too long, adjust the nut down, and vice versa. Once the belt reaches the desired position, tighten nut A to secure the belt length.
Note: After adjusting the belt, the gap between nut A and B must be within 35mm(1.4"). If the gap still exceeds the 35mm limit, you need to perform the following modifications:
 - A. Loosen the screws as pointed by the arrow-C, and adjust the belt to the proper length.
 - B. Tighten the screws pointed by the arrow-C.
3. After finishing the above adjustments, perform the whole- machine -test again to ensure the unit functions properly.

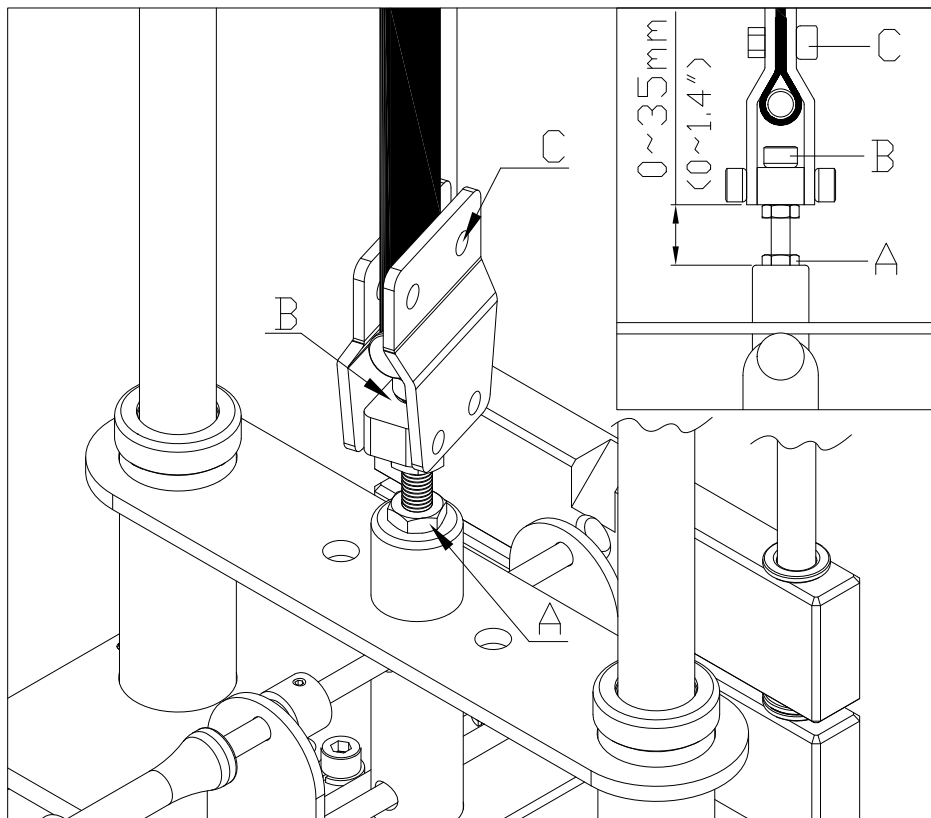

STEP 9 Unit Inspection

After completing the assembly or regular maintenance, please follow instructions (a) through (c) to inspect the unit. If the unit is disassembled or has been damaged in any way, it might cause injuries or cause the unit to fail.

- (a) Make sure the unit is steady and is on a level surface. If not, make adjustments according to the instructions “Secure the Unit” in this manual.
- (b) Make sure all parts are assembled and all fasteners are tightened.
- (c) Please follow operating instructions to test operation and make sure that the equipment is working properly. (Please refer to “Operate the Product” in this manual.)

5. OPERATION THE PRODUCT

This section includes operational instructions.

OPERATION Safety Operating Area

- (a) Safety clearance required is shown below. Do not allow access for people to near this area when operating.
- (b) Noise emission under load is higher than without load.
- (c) Over exercise or improper workout position may result in serious injury.
- (d) This equipment is intended to build shoulder muscles.

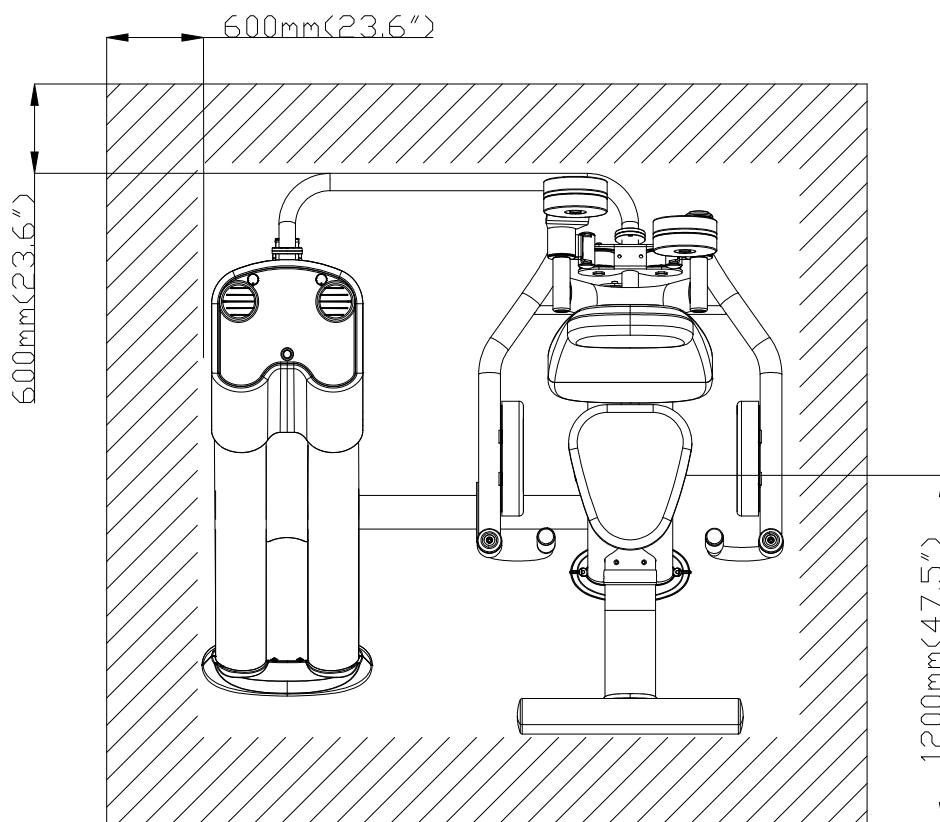

OPERATION Exercising Instructions

- (a) Select the appropriate weight stacks according to your recommended exercise level.
- (b) Adjust the seat height to the most comfortable position and make sure the knob is engaged to secure the position.
- (b) Perform the exercise in a controlled manner. Inhale when pushing up against resistance and exhale when returning to original position.
- * Always workout at a level that is tolerable, to stay in the proper training zone for your body. DO NOT work to exhaustion.
- * Use equipment ONLY under the supervision of trained and qualified instructors for safety reasons.
- * Please follow operating instructions on the product sticker to test operation and make sure the equipment is working properly.

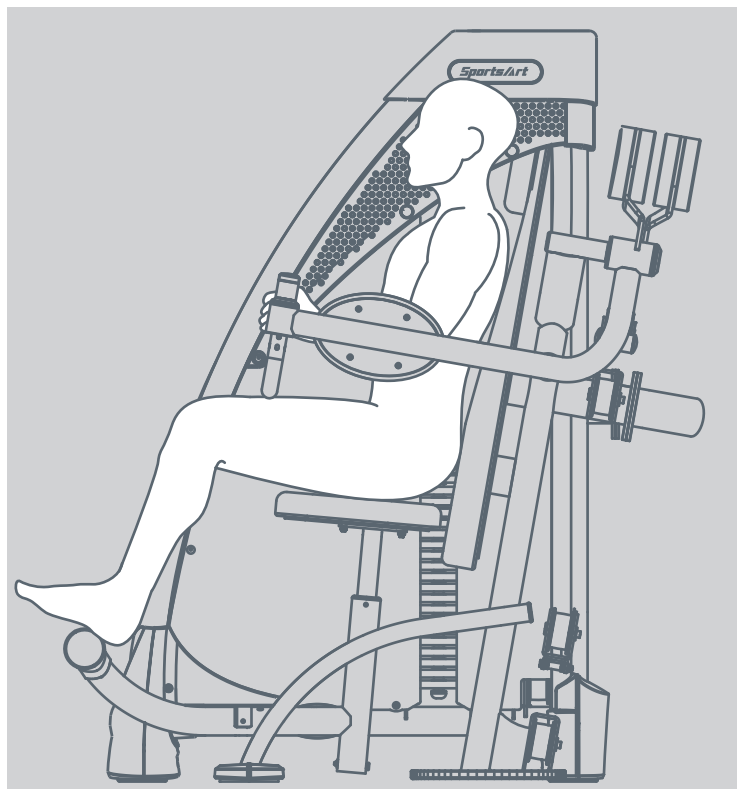

6. MAINTENANCE

This section covers maintenance topics and includes a maintenance schedule, task list, and log.

MAINTENANCE Safety Precautions

- Please follow standard safety precautions when servicing on this product.
- Do NOT use a damp towel to clean the product and do perform the following maintenances.
- Do NOT use cleaners with alcohol, ammonia, or other damaging chemicals. The use of such chemicals can damage the product and void the warranty. Never spray or pour any liquid directly onto the product. Doing so can damage components and void the warranty.
- Use a clean, lint-free towel, dampened with a mixture of Simple Green® all-purpose cleaner, to thoroughly clean the handlebar and the console.
- This product has moving parts that can be hazardous. Exercise caution when maintaining, operating, or moving this product.
- Do not use accessories or parts that are not specifically recommended by the manufacturer (SportsArt). Such parts might cause injuries or cause the unit to fail and void the warranty. We will not be responsible for any safety issue that arises due to the misuse of accessories or parts. At the same time, we will terminate the warranty terms of this equipment.
- Maintenance and repair must be performed by trained service personnel only. Improper maintenance would not only damage the machine, but also may present a danger to the exerciser.
- Keep this product out of use until maintenance is completed.

MAINTENANCE Guide Rod Cleaning and Lubricating

1. Please clean and lubricate the guide rod once a week.
 - (a) Use a clean, lint-free towel to apply the lubricant onto the guide rods.
 - (b) Test the weight stacks on the guide rod and make sure the weight stacks move smoothly.
 - (c) Repeat step (a) and (b) 2-3 times.
2. Ensure proper settling of the belt tension after maintenance.

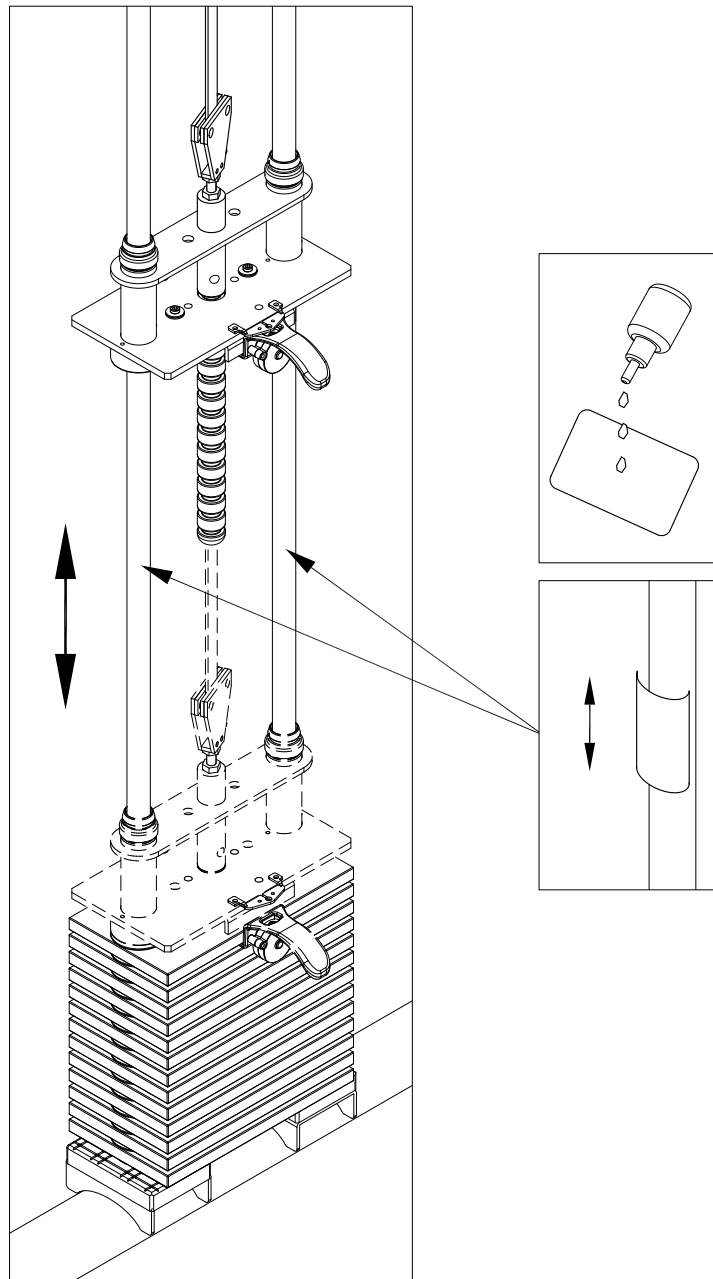

MAINTENANCE Important Note

1. Once the machine belt reaches the warranty period, replace the belt immediately.
2. Safety belt inspection: After a one-year period of usage, check the belt weekly for standard inspection. (The actual frequency of inspection depends upon the frequency of use)

Refer to the figure below for belt inspection: (A) the belt, (B) the belt extension.

Note: If you have a damaged or worn belt, stop using the equipment and replace the belt immediately.

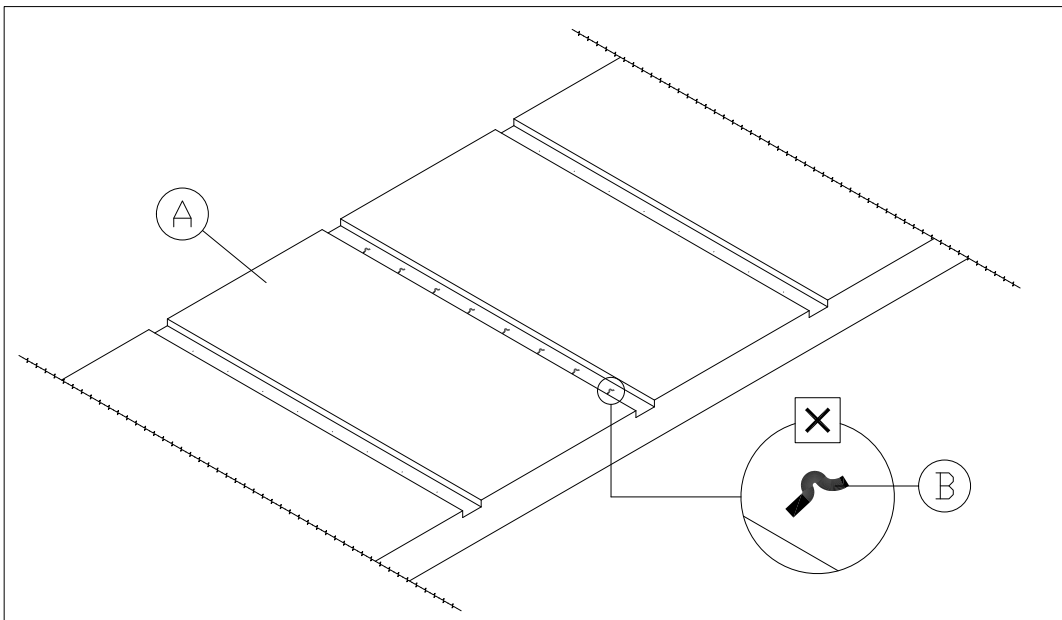

MAINTENANCE Schedule

If there is a need for maintenance of components, please visit the SportsArt website.

cleaning requirements

1.directive 93/42/CEE

2.directive biocide 98/8/CEE

The disinfectant has to be in compliance with Medical Device Directive 93/42/EEC (MDD) and Biocidal Products Directive 98/8/EC (BPD).

It is suited for sensitive synthetic surfaces such as synthetic leather, polycarbonate (PC), acrylic glass and polysulfone, and for the keyboards and control panels.

	Area	Day	Week	Month	Quarter	Year	Notes
1	Exterior	•					Clean.
2	Screws	•					Inspect and secure loose parts
3	Testing	•					Use performance testing to make sure the machine works as expected.
4	Cushions	•					Use a cloth moistened with water then wrung well, and wipe the cushions gently
5	Belt		•				Check for damage or wear. If so, replace it with a new one
6	Guide Rod		•				Clean and lubricate
7	Seat Tube		•				Clean and lubricate

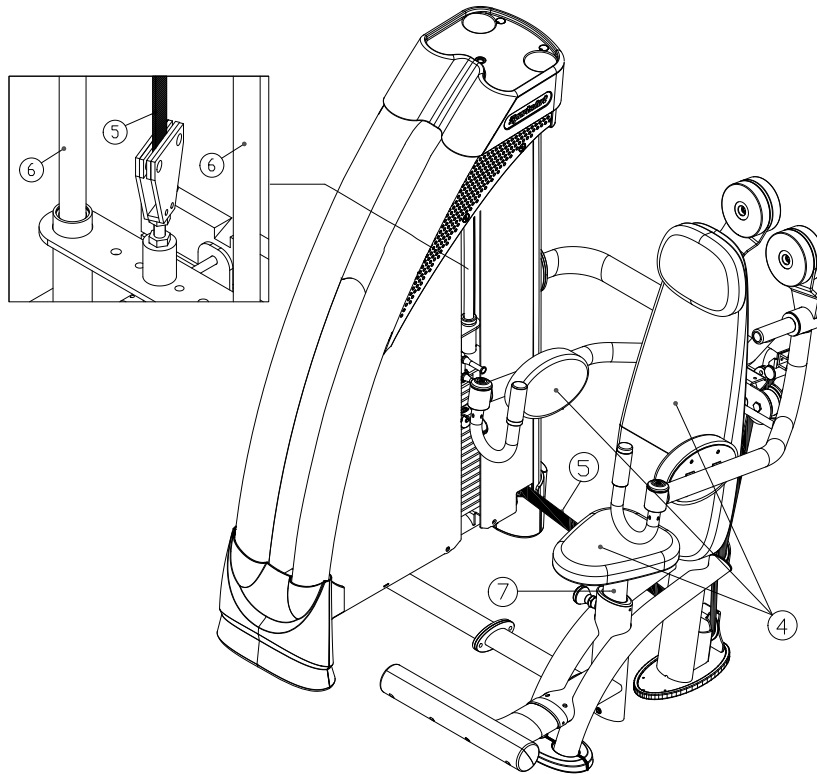

MAINTENANCE Task List

Like cars, fitness products require maintenance. Regular maintenance extends product life, and failure to maintain products can void the manufacturer's warranty. Copy the maintenance log sheet, and record maintenance work for each fitness product.

Daily tasks

1. Use a clean, lint-free towel to wipe down the product exterior.
2. Inspect all screws. Secure if necessary.
3. Make sure the machine is working properly.
4. Wipe cushions clean with a damp cloth.

Weekly tasks

1. Check the belt for damage or tear.
2. Clean and lubricate guide rods.
3. Clean and lubricate the seat tube.

Caution

- Please follow standard safety precautions when working on this product.
- Do NOT use cleaners with alcohol, ammonia, or other damaging chemicals. The use of such chemicals can damage the product and void the warranty. Never spray or pour any liquid directly onto the product. Doing so can damage components and void the warranty. Never spray or pour any liquid directly onto the product. Doing so can damage components and void the warranty.

MAINTENANCE Maintenance Log

Facility: _____ Supervisor: _____

Product model number: _____ Serial number: _____

Start date: _____ End date: _____

Daily Tasks	Week 1-7							Week 8-14							Week 15-21							Week 22-28									
Completed																															

Daily Tasks	Week 29-35							Week 36-42							Week 43-49							Week 50-52									
Completed																															

Weekly Tasks	Week 1-7							Week 8-14							Week 15-21							Week 22-28									
Completed																															

Weekly Tasks	Week 29-35							Week 36-42							Week 43-49							Week 50-52									
Completed																															

Monthly Tasks	1	2	3	4	5	6	7	8	9	10	11	12
Completed												

Quarterly Tasks	Quarter 1	Quarter 2	Quarter 3	Quarter 4
Completed				

Yearly Tasks	Year 1
Completed	

Notes: _____

7. CONSIGNES DE SÉCURITÉ IMPORTANTES

Le produit SportsArt a été conçu et fabriqué afin d'assurer une sécurité optimale. Cependant certaines précautions s'appliquent chaque fois que vous utilisez votre produit.

- Lisez entièrement le manuel avant l'assemblage et l'utilisation. Veuillez aussi noter les consignes de sécurité suivantes:
- Veuillez lire attentivement les instructions et installer le produit selon les instructions.
- Assemblez et faites fonctionner le produit sur une surface solide et plane; NE PAS l'utiliser à l'extérieur ou près de l'eau.
- En aucun cas, ne laissez des enfants à proximité ou sur le produit.
- Vérifiez le tapis de course avant chaque utilisation. Assurez-vous que toutes les pièces sont assemblées et que tous les éléments de fixation sont serrés. NE PAS utiliser le produit si l'appareil est démonté de quelque façon.
- Gardez vos mains loin des pièces mobiles.
- Portez des vêtements d'entraînement appropriés; NE PORTEZ PAS de vêtements amples. NE PORTEZ PAS de chaussures à semelles en cuir ou à talons hauts. Attachez les cheveux longs.
- Soyez prudent lors du montage et démontage de l'appareil.
- NE PAS utiliser d'accessoire non spécifiquement recommandé par le fabricant. Car cela pourraient provoquer des blessures ou entraîner une panne de l'appareil.
- Débranchez l'appareil de la prise avant l'entretien ou la suppression de toute pièce.
- Une surveillance étroite est nécessaire quand de produit est utilisé par ou à proximité d'enfants, de malades ou de personnes handicapées.
- Utilisez ce produit uniquement pour l'usage prévu dans ce manuel.
- La limite de poids de l'utilisateur pour le produit est de 227 kg, 500 lb.
- Ce produit n'est pas destiné à être utilisé par des personnes (y compris des enfants) dont les capacités physiques, sensorielles ou mentales sont réduites ou qui ne disposent pas de l'expérience ou du savoir nécessaires, sauf si celles-ci ont au préalable été formées eu égard à l'utilisation de produit par une personne responsable de leur sécurité.
- Les enfants doivent être encadrés afin d'empêcher qu'ils ne jouent avec le produit.
- Ce produit n'est pas destiné à être utilisé par des personnes (y compris des enfants) dont les capacités physiques, sensorielles ou mentales sont réduites ou qui ne disposent pas de l'expérience ou du savoir nécessaires, sauf si celles-ci ont au préalable été formées eu égard à l'utilisation de ce produit par une personne responsable de leur sécurité.
- Les enfants doivent être encadrés afin d'empêcher qu'ils ne jouent avec le produit.

ATTENTION

Si vous ressentez une douleur ou si vous avez une sensation anormale, ARRÊTEZ VOTRE ENTRAÎNEMENT et consultez immédiatement votre médecin. Entraînez-vous à votre niveau d'exercice recommandé. NE PAS s'entraîner jusqu'à l'épuisement. Avant de commencer un programme d'exercice, vous devriez consulter votre médecin. Il est recommandé de faire un examen physique complet. Dans ce manuel, les mots "gauche" et "droit" sont utilisés en référence aux pièces et au produit. Comme tels, les mots "gauche" et "droit" font respectivement référence aux côtés gauche et droit de l'exerciseur. De même pour plus de concision, le mot «vis» est utilisé dans certains cas où des rondelles, des vis et autres matériels sont associés.

8. APPENDIXES

APPENDIXES Exploded Diagram

Note: We reserve the right to revise the following diagrams at any time without notice or obligation to notify any person of such revisions or changes. Please visit our official website www.gosportsart.com for the latest version.

CHANGE DATE	CHANGE DESCRIPTION	CHANGE NO.	NAME		
<p style="text-align: center;">SportsArt FITNESS RESTRICTED USAGE, PLEASE DON'T FORWARD TO ANONE WHO CAN AUTHORIZE</p>					
DRAWN BY	VERIFIED BY	UNITS QTY	MM	SALES BLOW UP DIAGRAM	Diagram NO.
		1		XX	N919
		AO	1:16		

APPENDIXES Exploded Diagram

CHANGE DATE	CHANGE DESCRIPTION	CHANGE NO.	NAME
 RESTRICTED USAGE <small>PLEASE DON'T FORWARD TO ANYONE WHO DON'T AUTHORIZE</small>			
DRAWN BY	UNITS	SALES'S BLOW UP DIAGRAM NO.	
VERIFIED BY	QTY	GLQ-F101B-A	
	VERSION	MODEL	
	RAT110	N919	
	1:1:6		

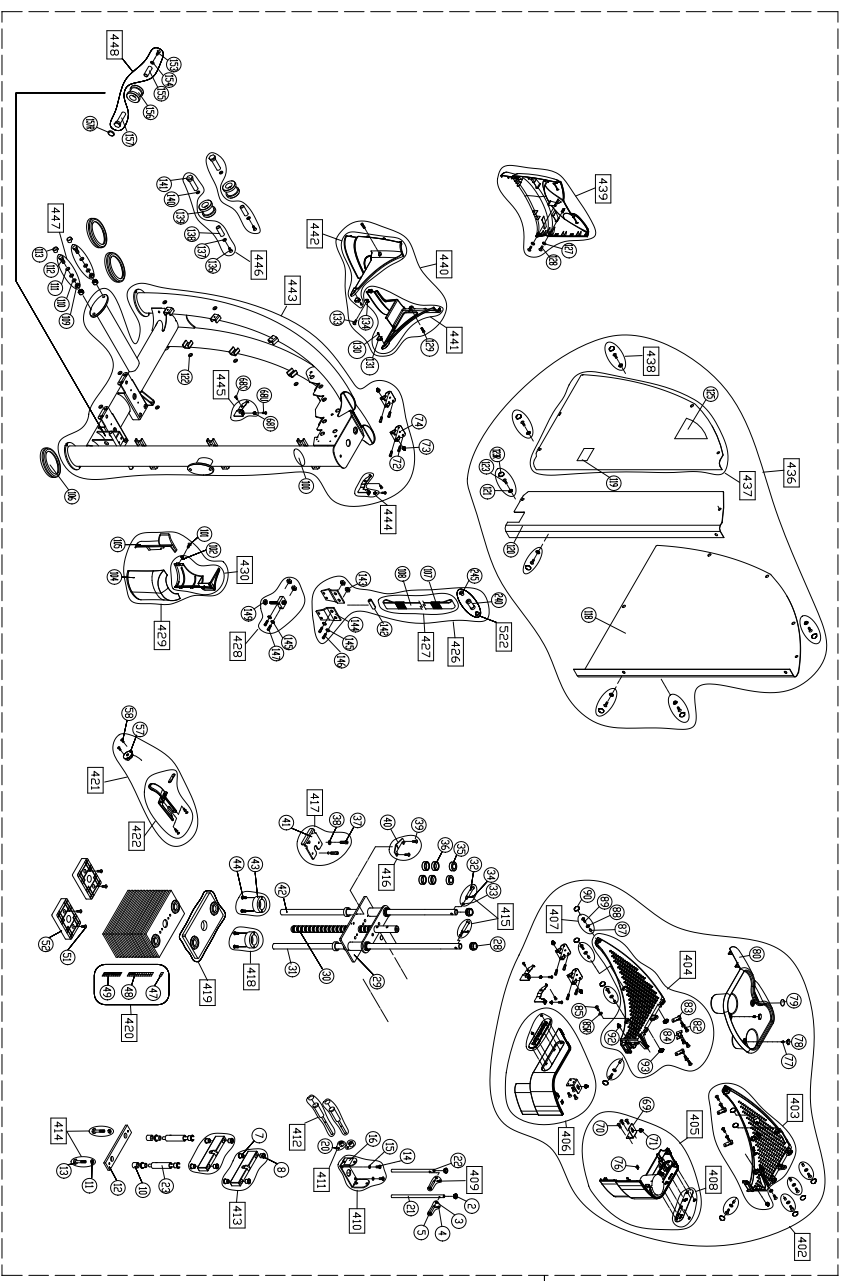

The diagram shows an exploded view of a fitness machine, likely a rowing machine or similar. The main frame is labeled 401. Various components are numbered, including:

- 402, 403, 404, 405, 406, 407, 408, 409, 410, 411, 412, 413, 414, 415, 416, 417, 418, 419, 420, 421, 422, 423, 424, 425, 426, 427, 428, 429, 430, 431, 432, 433, 434, 435, 436, 437, 438, 439, 440, 441, 442, 443, 444, 445, 446, 447, 448.

 The diagram illustrates the assembly sequence and relative positions of these parts.

Your Authorized Distributor