

# P855 OWNER'S MANUAL CONTENTS

1. INTRODUCTION .....	2
2. SAFETY PRECAUTIONS .....	3
3. LIST OF PARTS .....	4
4. ASSEMBLE THE PRODUCT .....	9
STEP 1 Cover Support Plate and the Connector Installation .....	9
STEP 2 Weight Stack Installation .....	14
STEP 3 Foot Swing Rod/Plate and the Cable Installation .....	18
STEP 4 Chest Cushion Installation .....	22
STEP 5 Apply the Weight Plate Sticker .....	23
STEP 6 Install the Front and Rear Covers .....	24
STEP 7 Install Plastic Cover .....	25
STEP 8 Install Cap Nut .....	26
STEP 9 Secure the Product .....	27
STEP 10 Cable Adjustment .....	28
STEP 11 Stack Fork Inspections .....	29
STEP 12 Level the Product .....	30
STEP 13 Unit Inspection .....	31
5. OPERATION INSTRUCTION .....	32
OPERATION Safety Operating Area .....	32
OPERATION Exercising Instructions .....	33
6. MAINTENANCE .....	35
MAINTENANCE Safety Precautions .....	35
MAINTENANCE Guide Rod Cleaning and Lubricating .....	36
MAINTENANCE Schedule .....	37
MAINTENANCE Task List .....	38
MAINTENANCE One-Year Maintenance Log .....	39
7. CONSIGNES DE SÉCURITÉ IMPORTANTES .....	40
8. APPENDIXES .....	41
APPENDIXES Exploded Diagram .....	41

## Disclaimer

The information in this user manual is subject to change without prior notice.

Sports Art Industrial Co., Ltd. makes no representation or warranty of any kind, express or implied, regarding the marketability of this manual, the suitability for a special purpose, or any other matters.

SportsArt Industrial Co., Ltd. accepts no responsibility for any errors in this manual, or any damages incurred directly, indirectly, accidentally, or continually from the modification, display, or other use of this manual.

\*We reserve the right to revise this manual at any time without notice.

# 1. INTRODUCTION

Congratulations on the purchase of a high quality SportsArt product, the P855 Glute machine. Constructed of high quality materials and designed for years of reliable performance, this product was made for full commercial use.

Before this product is assembled or operated, we recommend that you familiarize yourself with this manual. Understanding the correct assembly and operation of this product will help ensure that exercisers obtain their fitness goals safely and successfully.

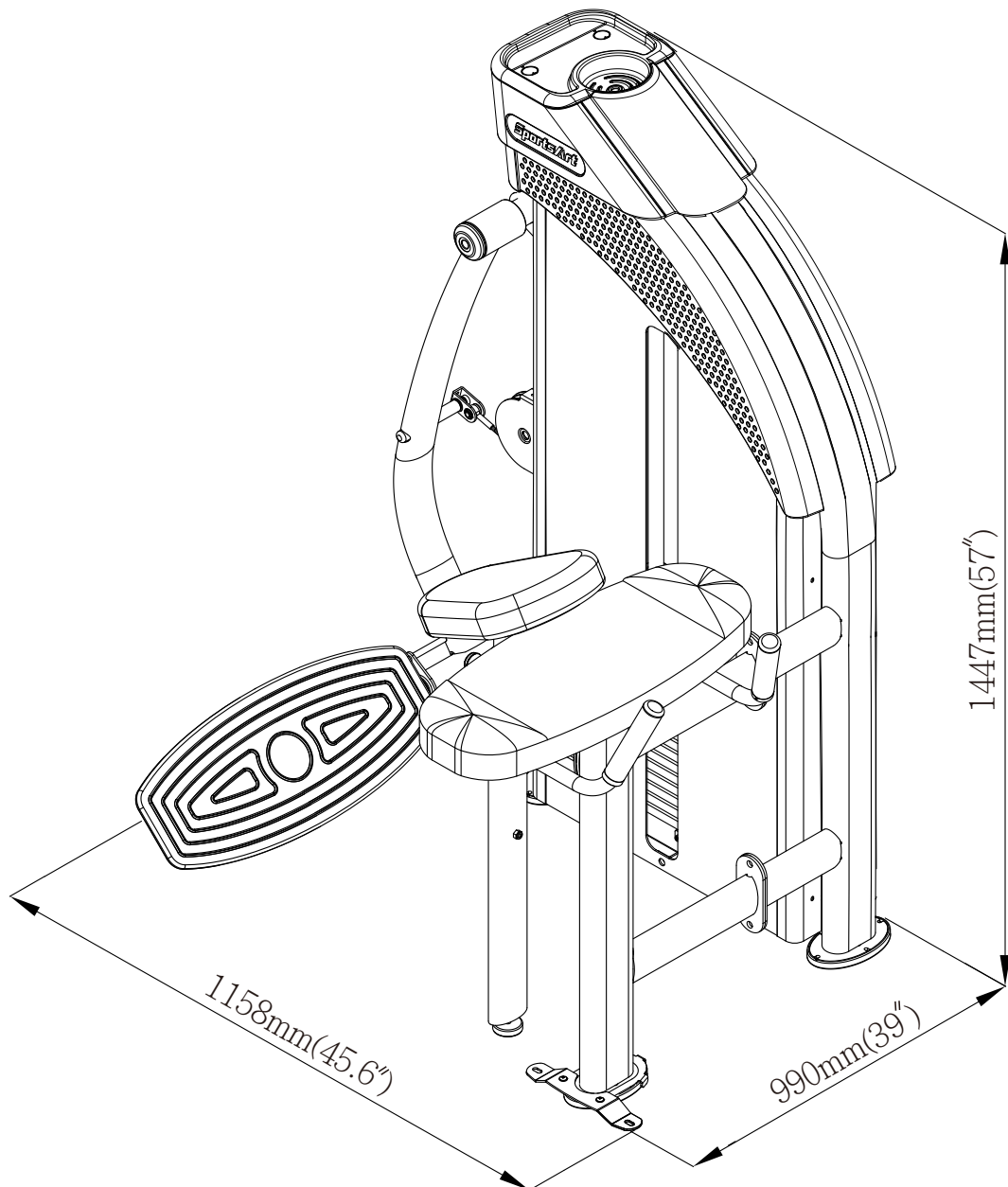

## 2. SAFETY PRECAUTIONS

This product was designed and built for optimum safety. However certain precautions apply during the use of this product. Please note the following safety precautions:

- Please read the entire manual before assembly and operation. Make sure the product is installed and operated as instructed in this manual.
- Assemble and operate the product on a solid, level surface. Do not use outdoors or near water, including pools and saunas.
- Check the product before every use. Make sure all parts are assembled, and all fasteners are tightened. Do not use the product if it is disassembled in any way.
- Wear proper workout clothing. Do not wear loose clothing. Do not wear shoes with leather soles or high heels. Tie all long hair back. Do not go barefoot on this product.
- Keep away from moving parts. Moving parts may or may not stop immediately if an object becomes caught or impedes normal motion.
- Use this product only for its intended purpose as described in this manual.
- Be careful when mounting and dismounting the unit.
- Never operate this product if it has been damaged in any way. If it is not working properly, or has been dropped or damaged, contact a service technician for repairs.
- Do not use accessories or parts that are not specifically recommended by the manufacturer (SportsArt). Such parts might cause injuries or cause the unit to fail and void the warranty. We are not responsible for any safety issue that arises due to the misuse of accessories or parts. At the same time, we will terminate the warranty terms of this equipment.
- This product is not intended for use by persons (including children 12 or younger) with reduced physical, sensory, or mental capabilities, or by people who are otherwise deficient in product knowledge or experience. If such people use this product, they should be given training and be supervised at all times by someone responsible for their safety.
- Contact your SportsArt representatives on all materials damaged in shipment. (Note: Shipping damages are the responsibility of the carrier.)
- Unpack and verify contents of boxes according to the list of parts to check if any parts are missing.
- Children 12 or younger should be supervised to ensure that they do not play on or near the product.
- The user weight limit for this product is 227 kg, 500 lb.
- Maintenance and repair must be performed by trained service personnel only. Improper maintenance would not only damage the machine, but may also present a danger to the exerciser.
- Over exercise may result in serious injury or death
- Warning that any of the adjustment devices that could interfere with the user's movement should not be left projecting.

**CAUTION:** If you feel any pain or any abnormal sensations, STOP YOUR WORK-OUT and consult your physician immediately. Work within your recommended exercise level. DO NOT work to exhaustion. Before beginning any exercise program, you should consult with your doctor. It is recommended that you undergo a complete physical examination.

\*NOTE: Each machine provides a different resistance ratio of weight stack.

# 3. LIST OF PARTS

Box A

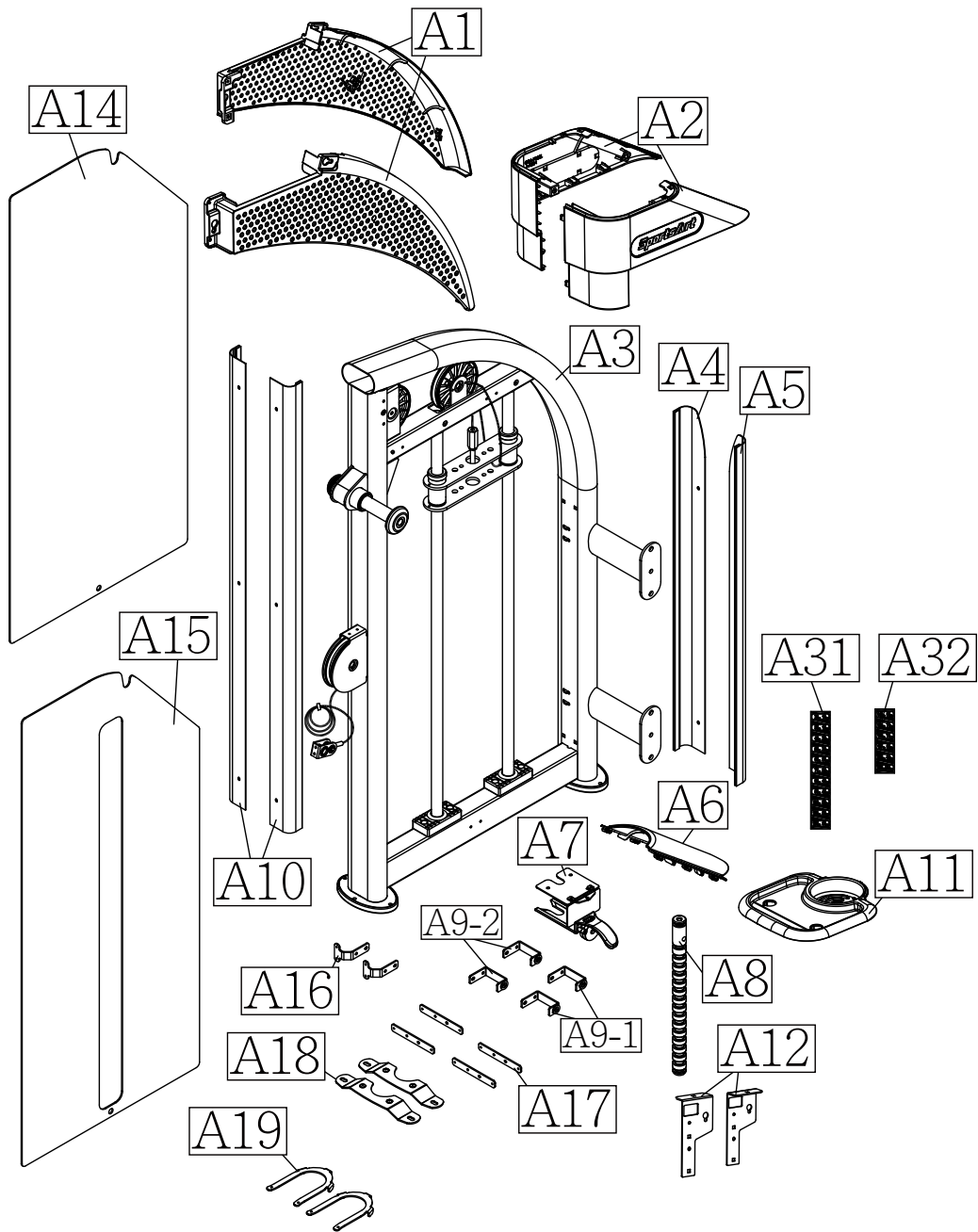

Box B

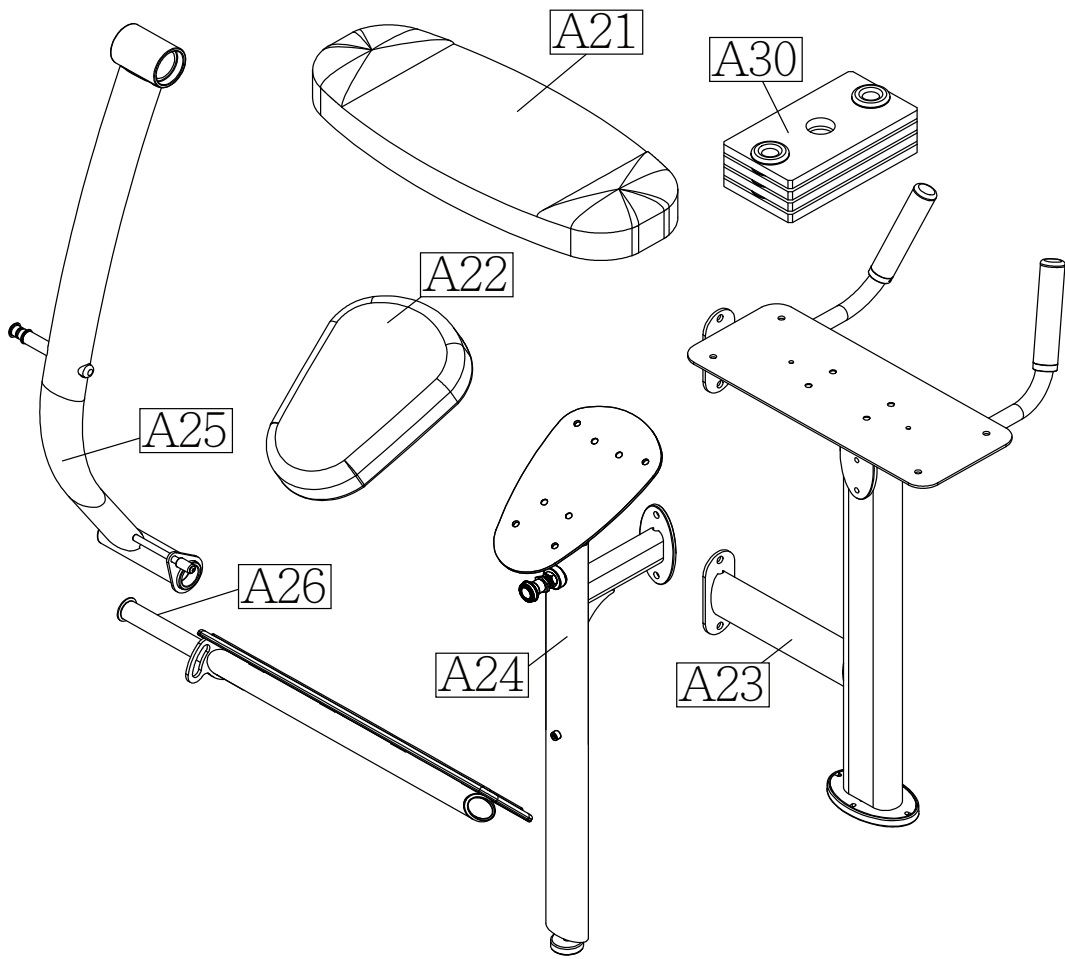

Box C

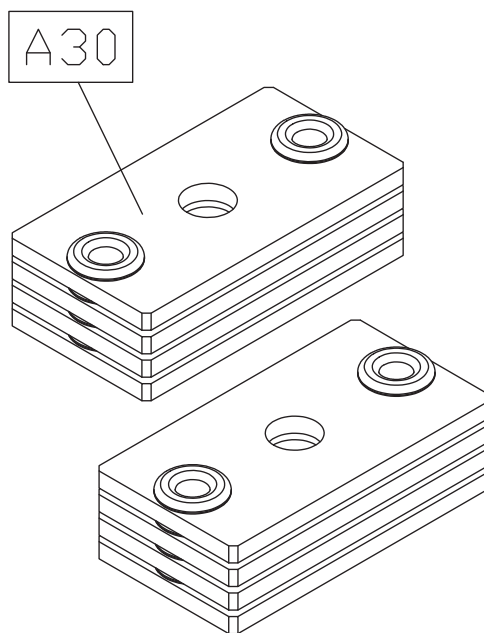

<b>Box A - Main Frame Components</b>					
<b>No.</b>	<b>Name</b>	<b>Qty.</b>	<b>No.</b>	<b>Name</b>	<b>Qty.</b>
A1	Left/right perforated boards	2	A10	Cover support plate A	2
A2	Left/right side cover	2	A11	Top cover	1
A3	Main frame	1	A12	Anchor bracket	2
A4	Cover support plate B-2	1	A14	Rear cover	1
A5	Cover support plate B-1	1	A15	Front cover	1
A6	Front cover A	1	A16	Bracket	2
A7	Stack fork	1	A17	Bracket	4
A8	Weight stack rod	1	A18	Floor fixing bracket	2
A9-1	Anchor bracket of shroud (square hole)	2	A19	U bracket	2
A9-2	Anchor bracket of shroud (tapped hole)	2	A31	Weight plate sticker (10kg~60kg/22lb ~132lb)	1
			A32	Weight plate sticker (65kg~100kg/143lb ~220lb)	1

<b>Box B - User Frame Components</b>					
<b>No.</b>	<b>Name</b>	<b>Qty.</b>	<b>No.</b>	<b>Name</b>	<b>Qty.</b>
A21	Seat back	1	A25	Foot swing rod	1
A22	Chest cushion	1	A26	Foot swing plate	1
A23	Seat frame A	1	A30	5kg/11lb weight plate	4
A24	Seat frame B	1			

<b>Box C - Weight Plates Components</b>					
<b>No.</b>	<b>Name</b>	<b>Qty.</b>	<b>No.</b>	<b>Name</b>	<b>Qty.</b>
A30	5kg/11lb weight plate	8			

<b>Components in the Hardware Kit</b>				
<b>No.</b>	<b>Name</b>	<b>Qty.</b>	<b>Specification</b>	<b>Notes</b>
10	Screw socket	1 batch	SGN-07	
11	Mushroom top inner hex screw	12	M6*P1.0*L12	
12	Mushroom top Phillips screw	8	M5*L15	
13	Mushroom top Phillips screw	10	M5*0.8*L8	
14	Phillips screw	6	M6*P1.0*L12	
15	Hex head screw	4	M10*P1.5*L30	
	Spring washer	4	M10	
	Washer	8	D16*d10.2*t1.0	
	Nylon hex lock nut	4	M10	
16	Round head inner hex screw	2	M6*P1.0*20	
	Bushing	2	D21.5*10.5	
17	Round sticker	1	D25	
18	Front cover support plate	1		
19	Flat washer	2	D27*d6.3*t3.0	
	Mushroom top inner hex screw	2	M5*L20	
21	Phillips pan head sheet metal screw	6	M4*L12	
22	Phillips Umbrella head sheet metal screws	2	M4*L14	
23	Round screw cap	2		
	L-shaped Allen wrench	2	(M4)	
	L-shaped Allen wrench	1	(M5)	
	L-shaped Allen wrench	1	(M6)	
	T-shaped Allen wrench	1	M4*L100	
	Open end wrench	2	(13*17)	
59	Fastener	1 batch		
	Cap nut	1 batch		

Components on the Product			
No.	Name	Specification	Notes
30	Hex head screw	M10*P1.5*L30	
	Spring washer	M10	
	Washer	D16*d10.2*t1.0	
31	Round head inner hex screw	M8*P1.25*L20	
32	Round head inner hex screw	M8*P1.25*L20	
	Flat washer	D38*d8.5*t1.5	
33	Upper stack carriage set		
34	Hex head screw	M8*P1.25*L65	
	Flat washer	D17*d8.3*t2	
	PU tube	D12*d8*L51	
	Nylon hex lock nut	M8	
35	Guide rod		
36	Round head inner hex screw	M8*P1.25*L18	
	Spring washer	M8*t2.0	
	Flat washer	D17*d8*t1.5	
37	Mushroom top inner hex screw	M8*P1.25*L25	
	Spring washer	M8	
38	Screw soft cap	Ø 65	
41	Mushroom top inner hex screw	M6*P1.0*L12	
	Flat washer	D20*d6.3*t1.5	
42	Mushroom top Phillips screw	M5*0.8*L15	
	Flat washer	D13*d6*t1.0	
46	Reinforcement plate		
	Anchor bracket		
	Umbrella hex screw	M6*P1.0*L20	
	Plastic cover		
47	Umbrella hex screw	M6*P1.0*L12	

## 4. ASSEMBLE THE PRODUCT

Follow instructions below to assemble this product. Note that in this manual the words “left” and “right” are used to refer to the product and its parts. As such, these designations correspond to the “left” and “right” sides of a person in position to exercise on this product. Also, for brevity, the word “screws” or “nuts” is used where washers and other hardware may be involved.

### STEP 1 Cover Support Plate and Connector Installation

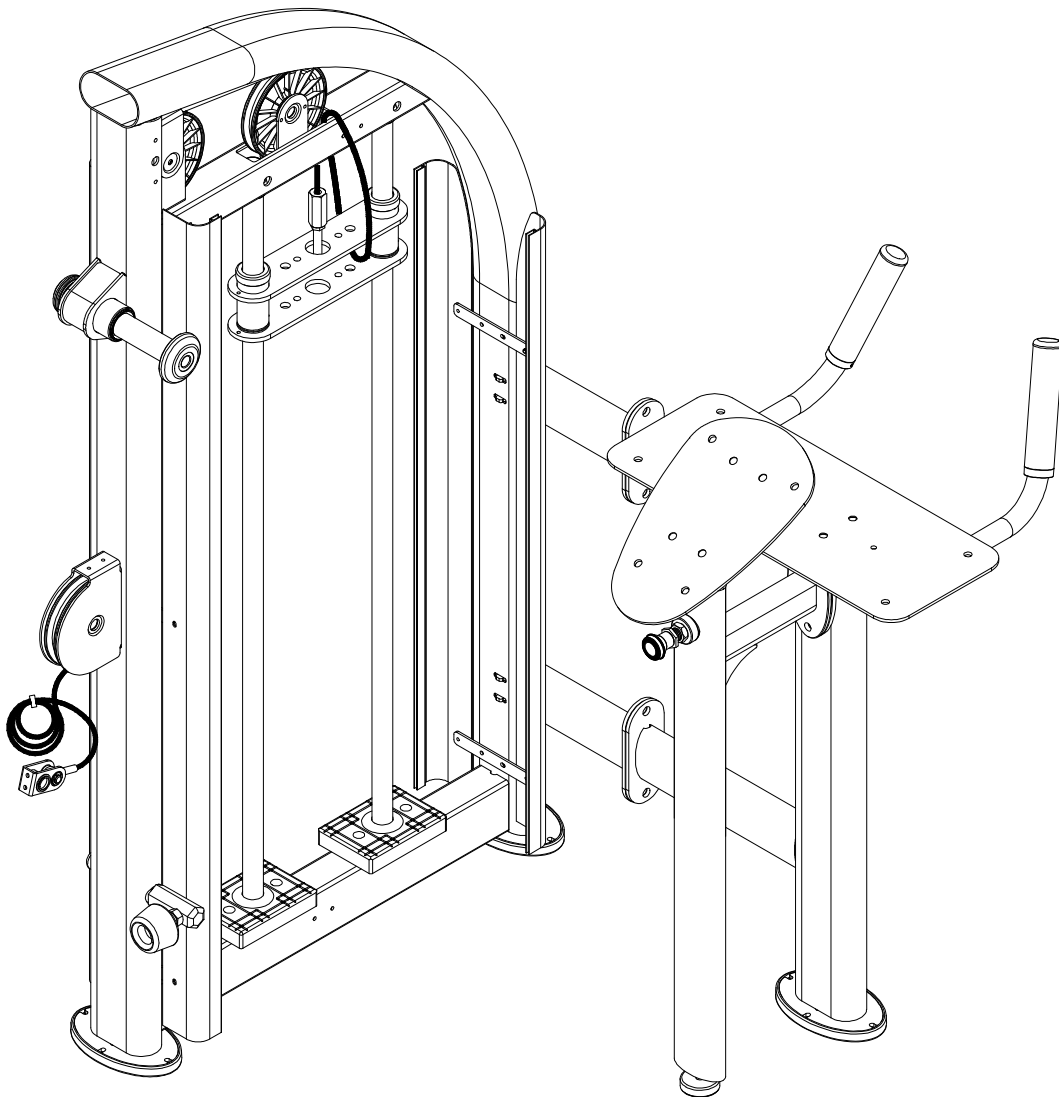

## STEP 1 Cover Support Plate & Connector Installation (CONT.)

- (a) Insert the screw sockets (10) into place in the main frame (A3) as shown, and then use screws (11) (12) to secure the brackets (A16) (A17) in place.  
(Note: The bracket (A16) must be secured to the top of main frame as shown.)

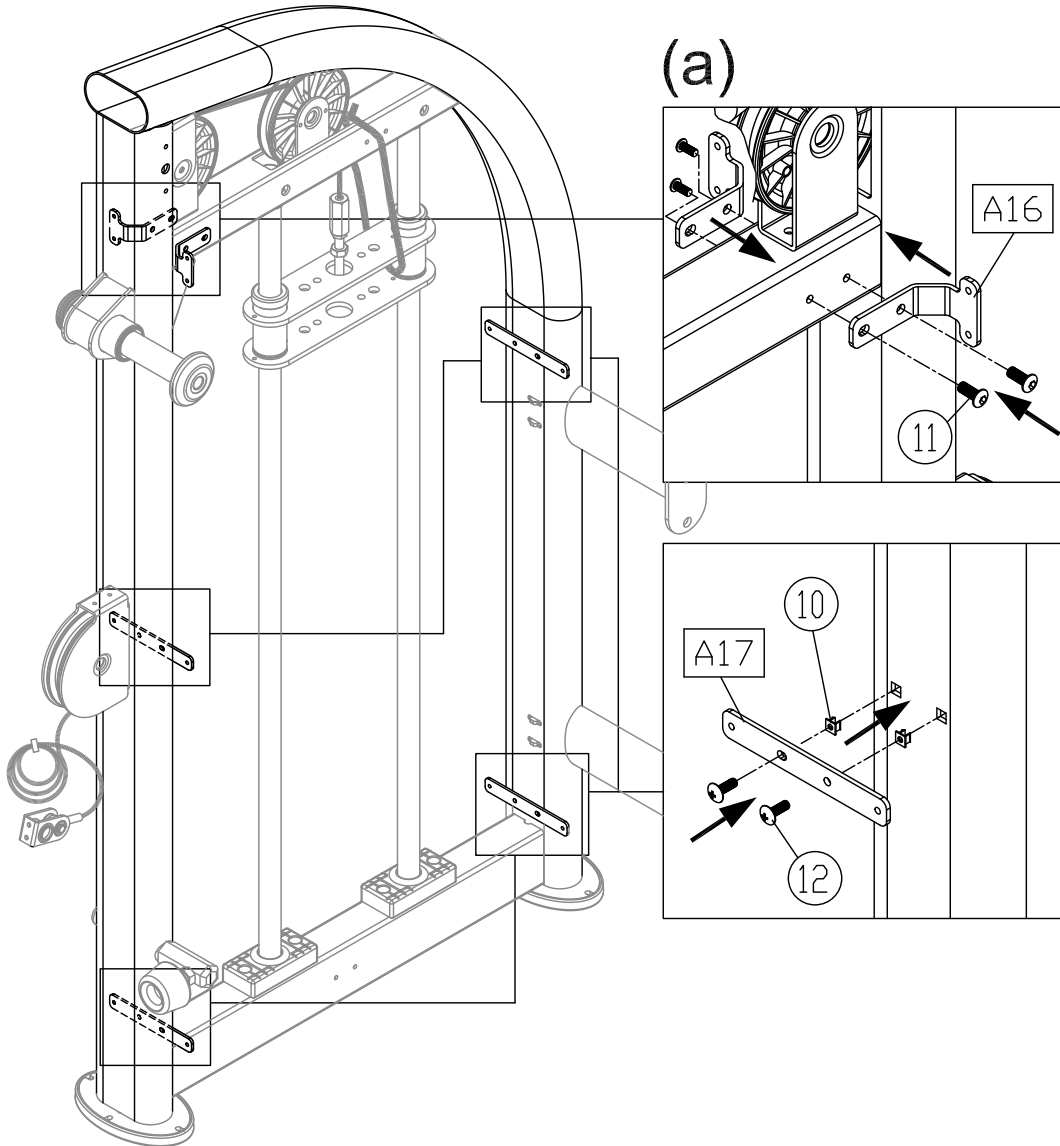

## STEP 1 Cover Support Plate & Connector Installation (CONT.)

- (b) Secure the plate slots (A10) to the straight frame of the weight stack tower (A3) with the screws (13) and then cover the cap nuts (60). The plate slots (A4, A5) are secured to the left and right side of the curved frame, respectively. (Note: The plate slots have to be secured outside of the anchor brackets (A16, A17).)

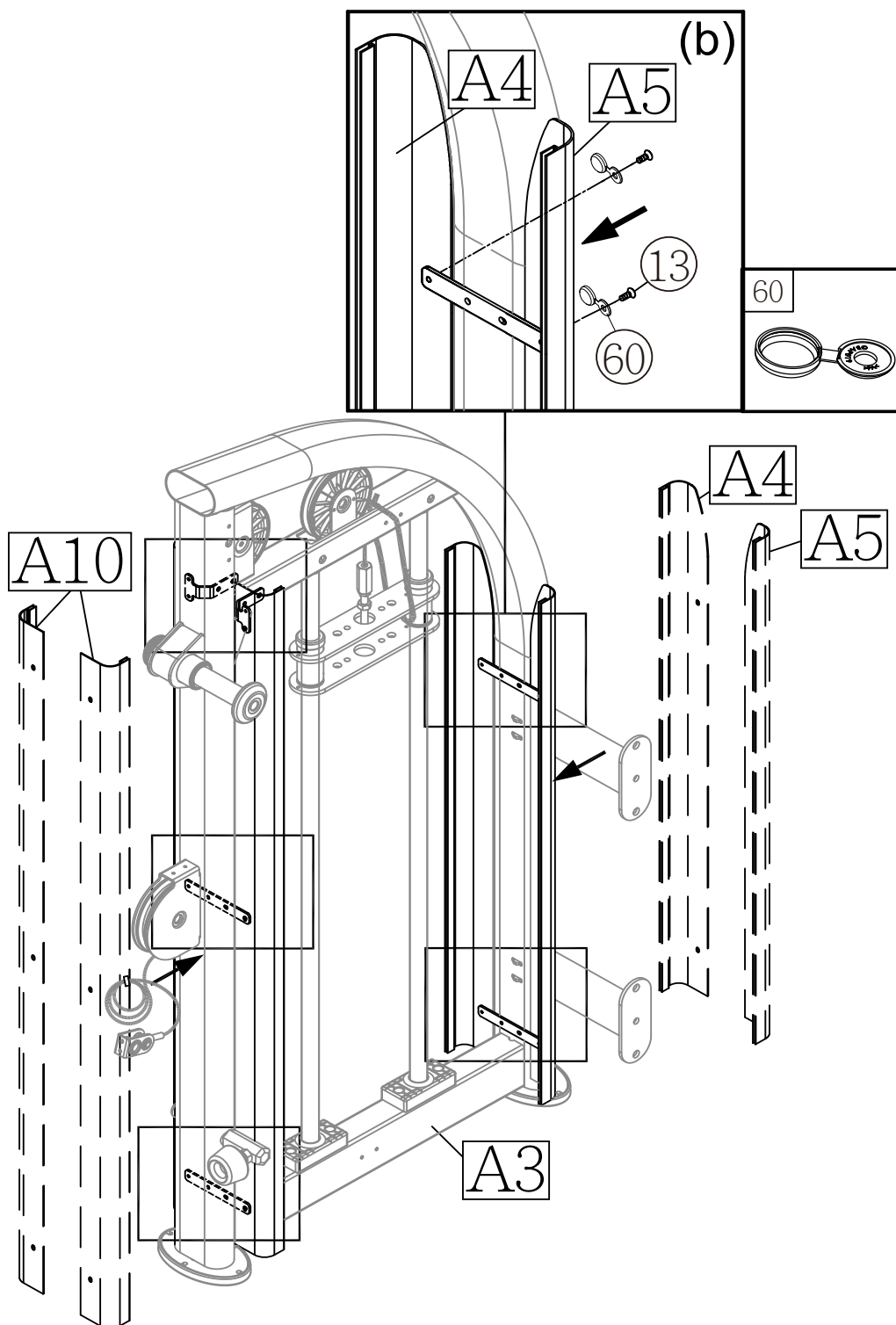

**STEP 1** **Cover Support Plate & Connector Installation (CONT.)**

- (c) Loosen and remove screws (30) from the seat frame A (A23).
- (d) Use screws (30) to secure the seat frame B (A24) to the straight frame of the seat frame A (A23).

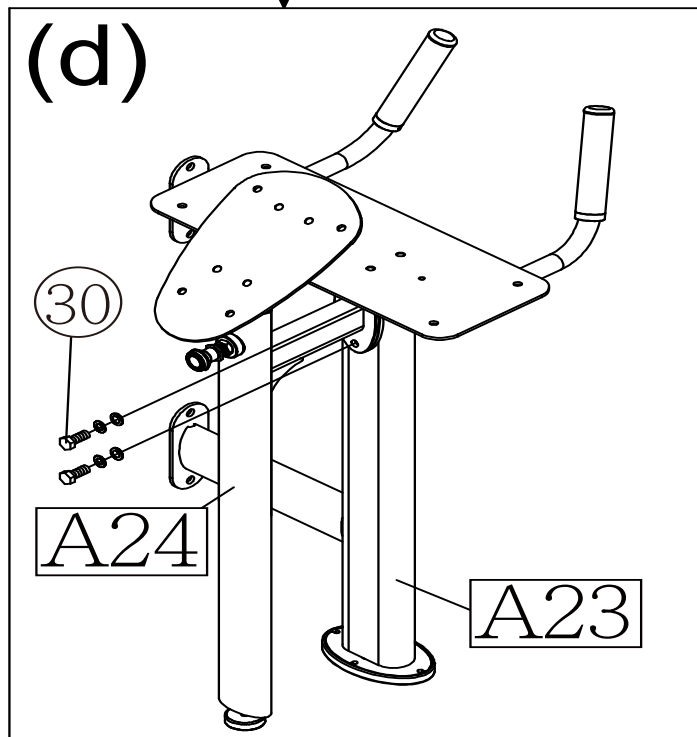
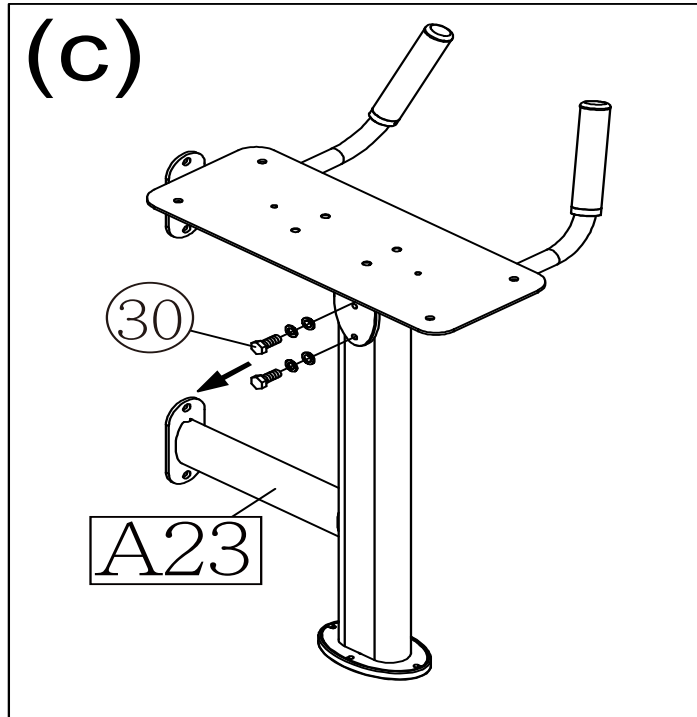

**STEP 1** **Cover Support Plate & Connector Installation (CONT.)**

(e) Connect the seat frame A (A23) to the main frame (A3) and align holes, and then secure with screws (15) as shown.

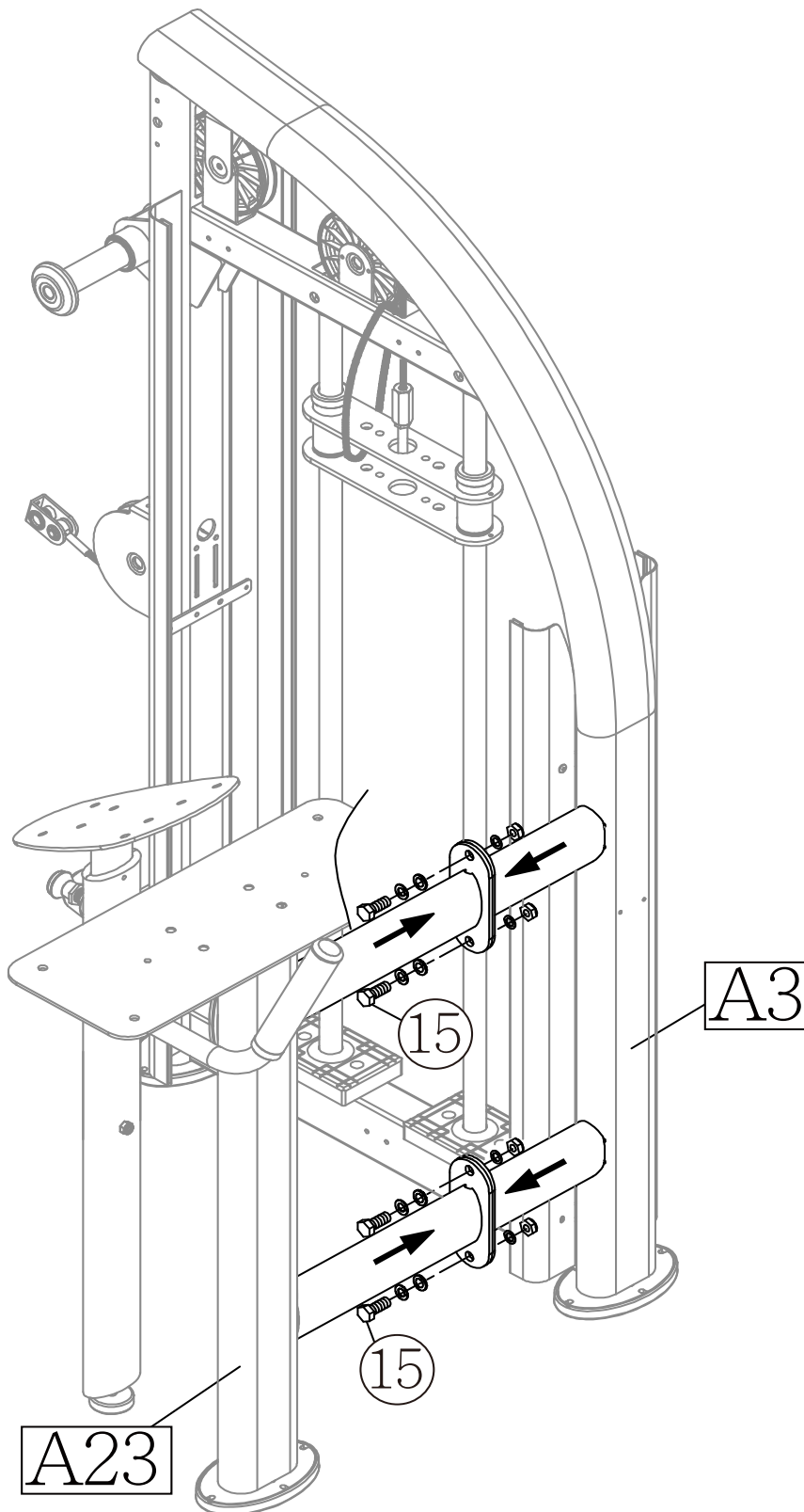

## STEP 2 Weight Stack Installation

---

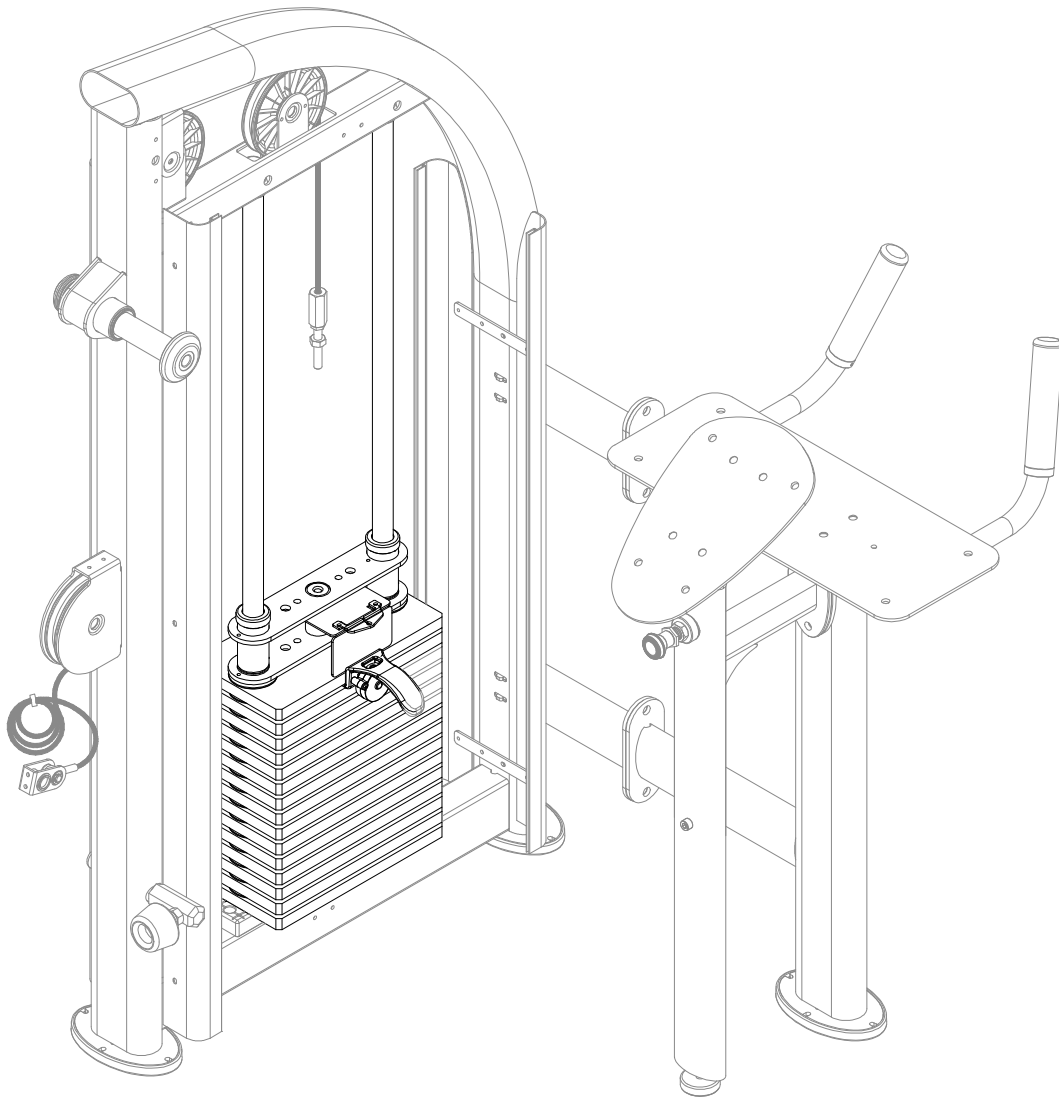

## STEP 2 Weight Stack Installation (CONT.)

- (a) Hold the upper stack carriage set (33), and then cut the zip tie. Gently lower the upper stack carriage set (33) into place as shown.
- (b) Remove screws (34). Set the guide rod (35) downward into place as shown.
- (c) Tilt the guide rod (35) backward and then lift the upper stack carriage set (33) off the guide rods as shown. Carefully set the upper stack carriage set (33) aside.

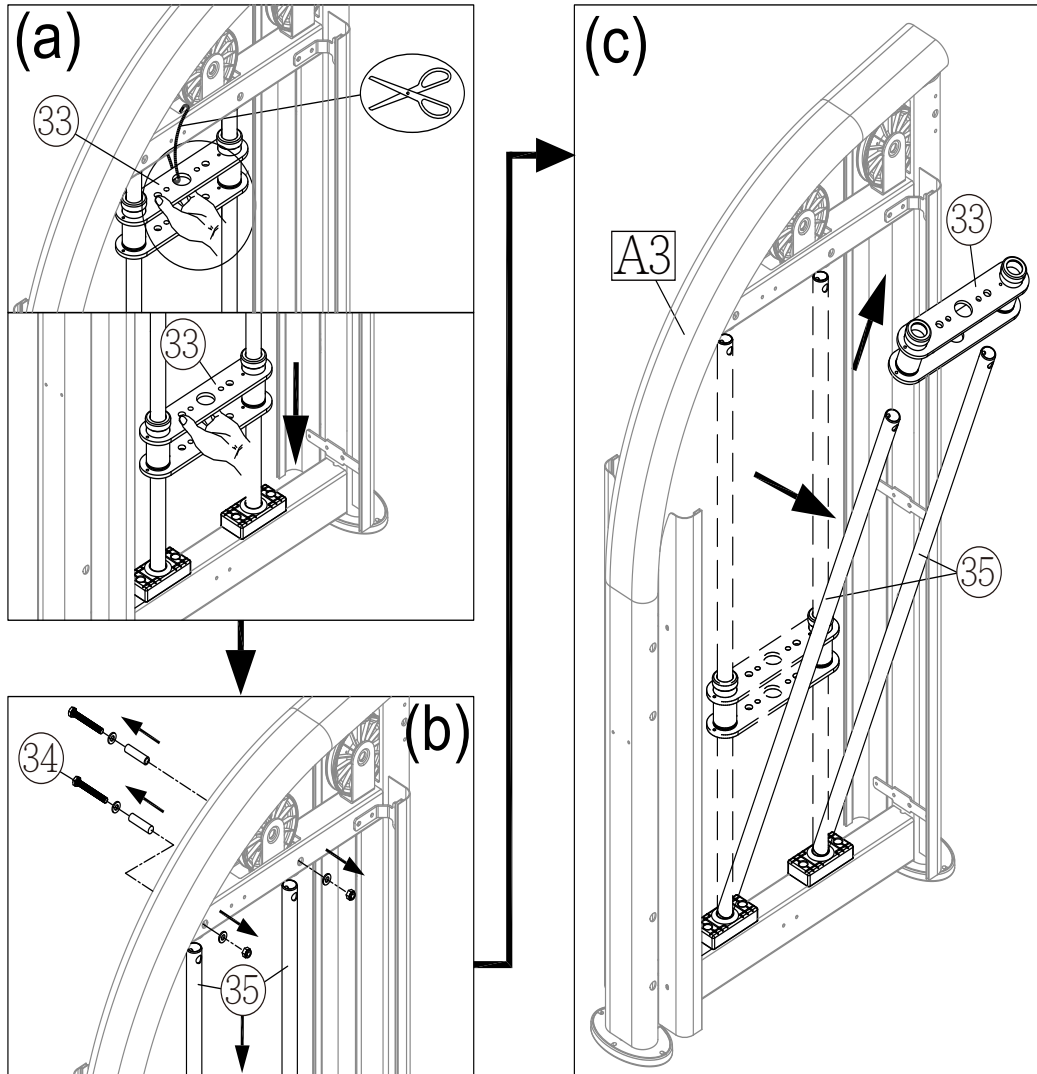

## STEP 2 Weight Stack Installation (CONT.)

(d) Loosen and remove screws (36) from the stack fork (A7) and insert the weight stack rod (A8) into the central mounting position of the upper stack carriage set (33). Use screws (36) to secure the stack fork (A7) into place of the upper stack carriage set (33) as shown.

*(Note: Remove the stack fork first before assembling.)*

(e) Insert and lower the (5 kg/11lb) weight plates (A30) into place on the guide rods (35) one at a time. Once complete, slide down the upper stack carriage set (33) on top of the weight stack.

*(Note: The convex side of weight plate should face up and the stack fork (A7) points toward the front.)*

\* If there is an optional (7.5kg/16.5lb) weight plate installed, insert the optional weight plates first before the (5 kg/11lb) weight plates (A30).

\* Install the cap nuts on the screws.

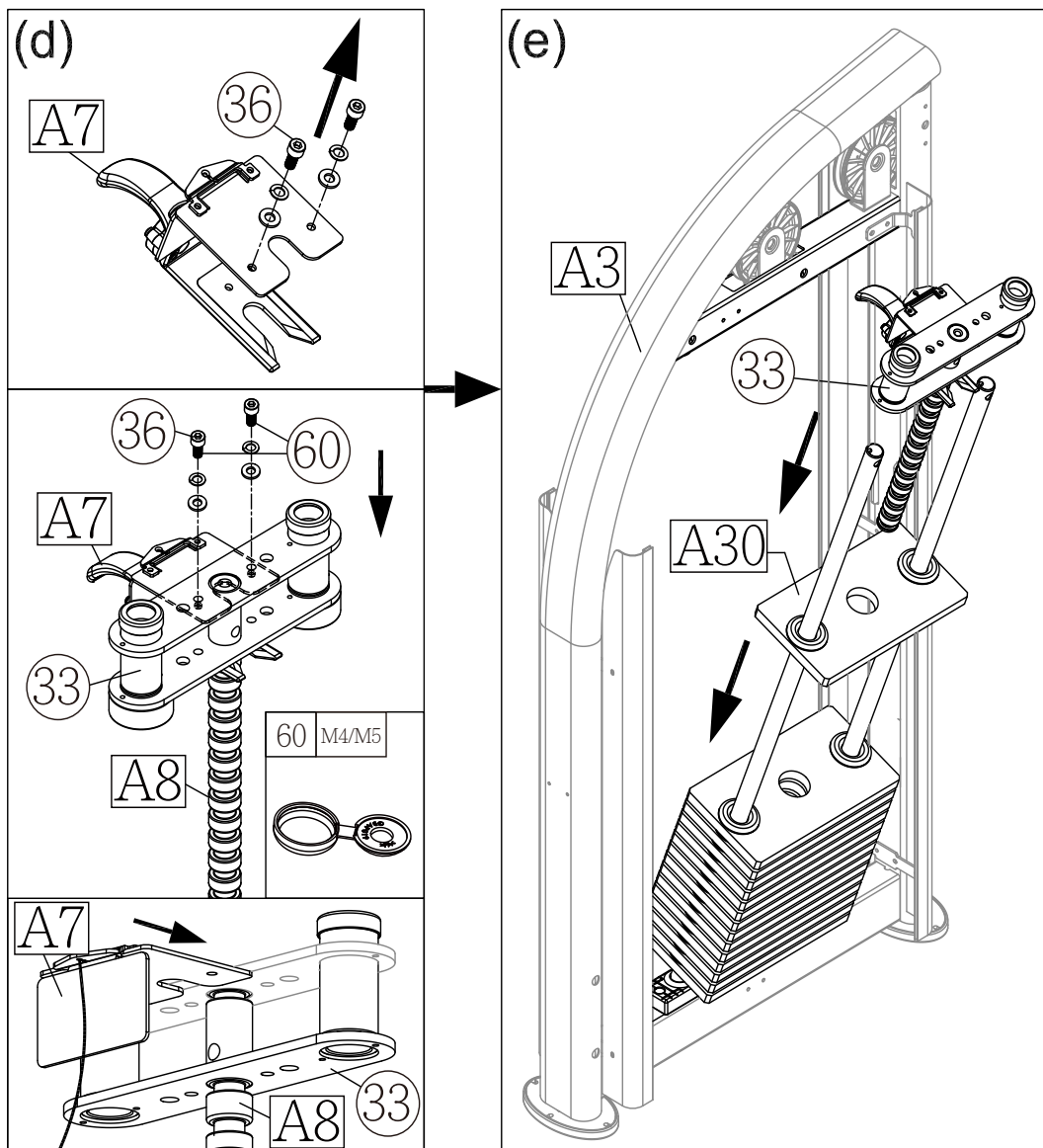

## STEP 2 Weight Stack Installation (CONT.)

(f) Tilt the guide rods (35) back into place and then lift them up to their mounting position, and then secure the assembly with screws (34).

\* Install the cap nuts on the screws.

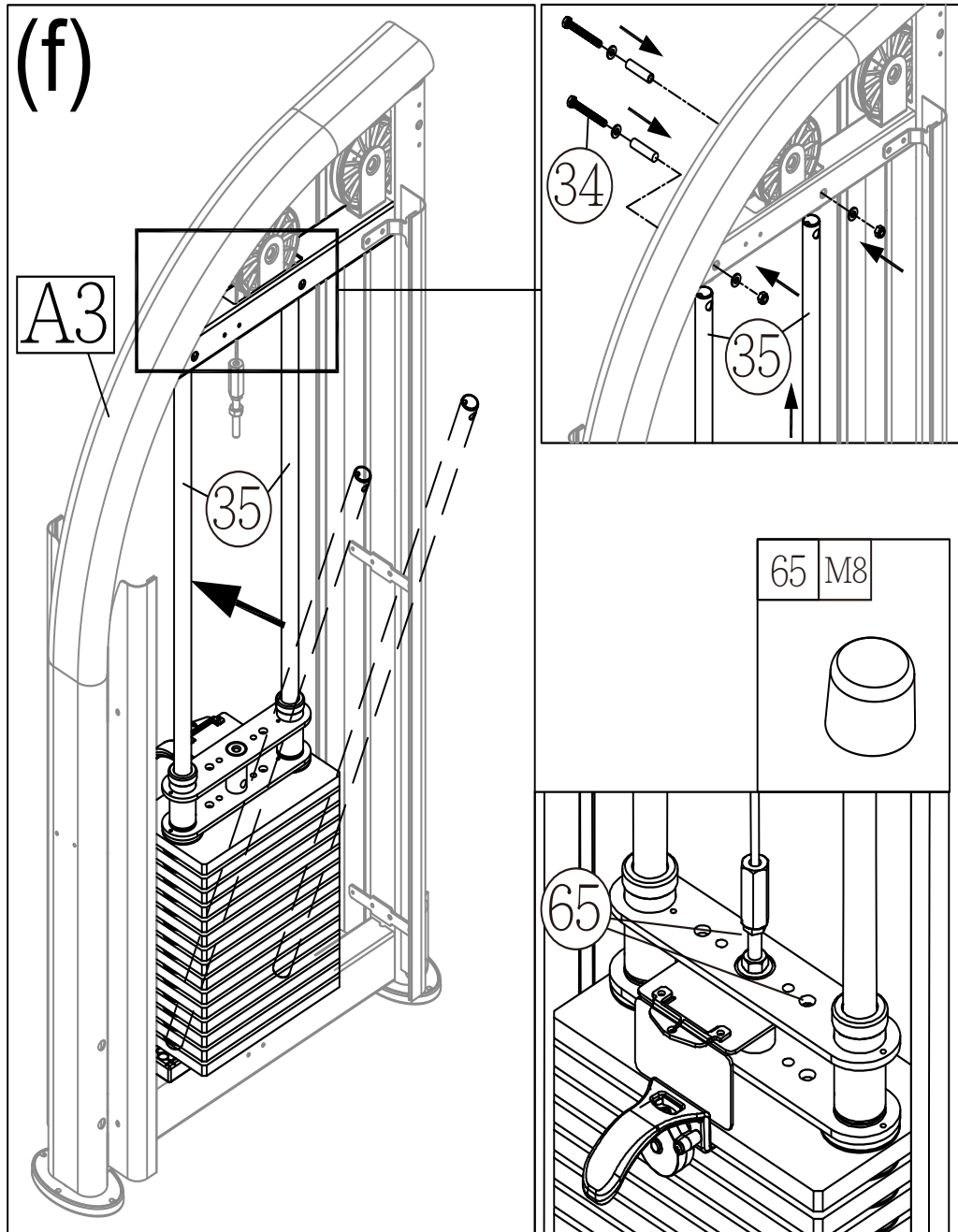

**STEP 3** Foot Swing Rod/Plate and Cable Installation

---

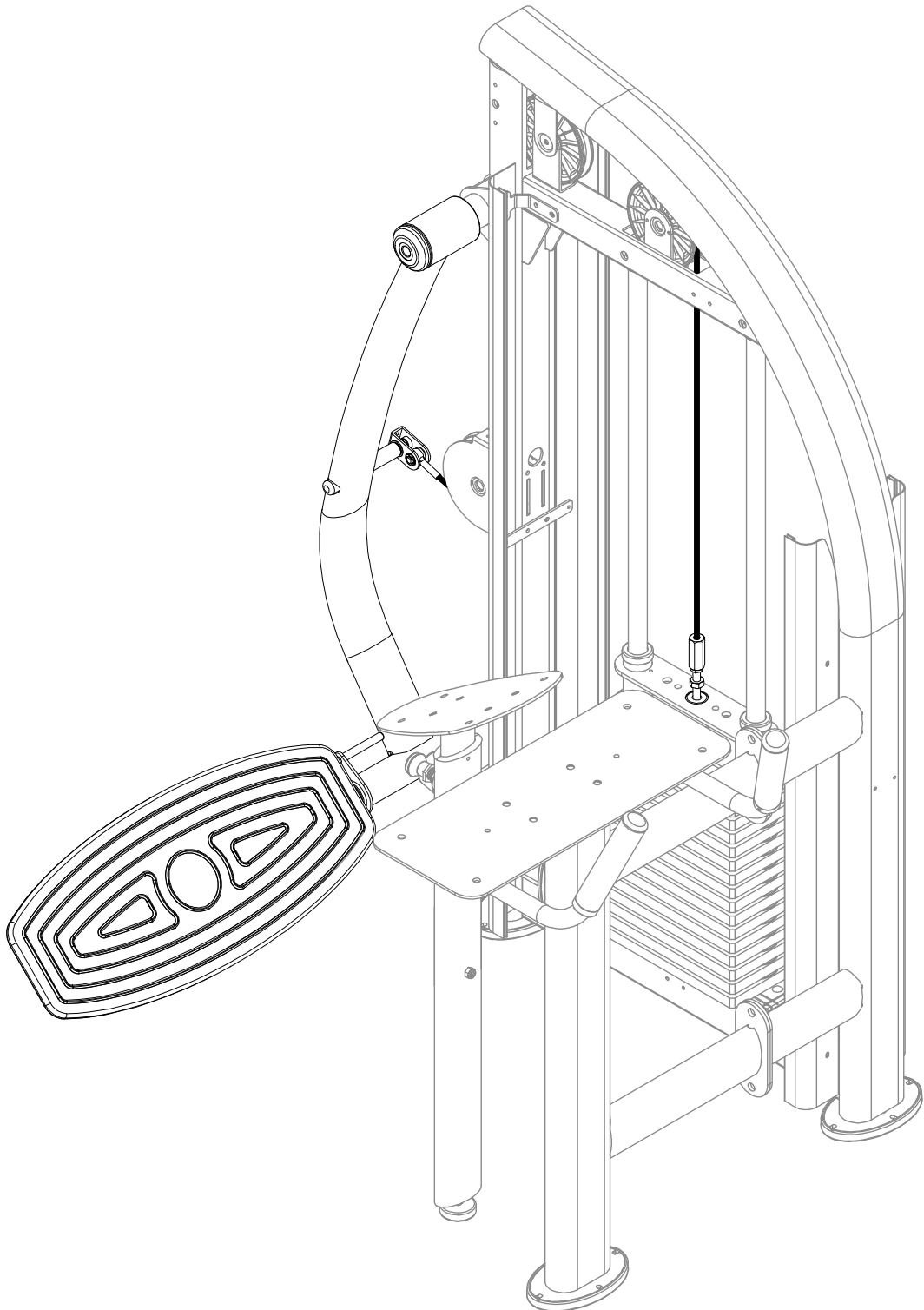

### STEP 3 Foot Swing Rod/Plate & Cable Installation (CONT.)

- (a) Loosen and remove screws (32) and the screw soft cap (38) from the main frame (A3) and the foot swing plate (A26).

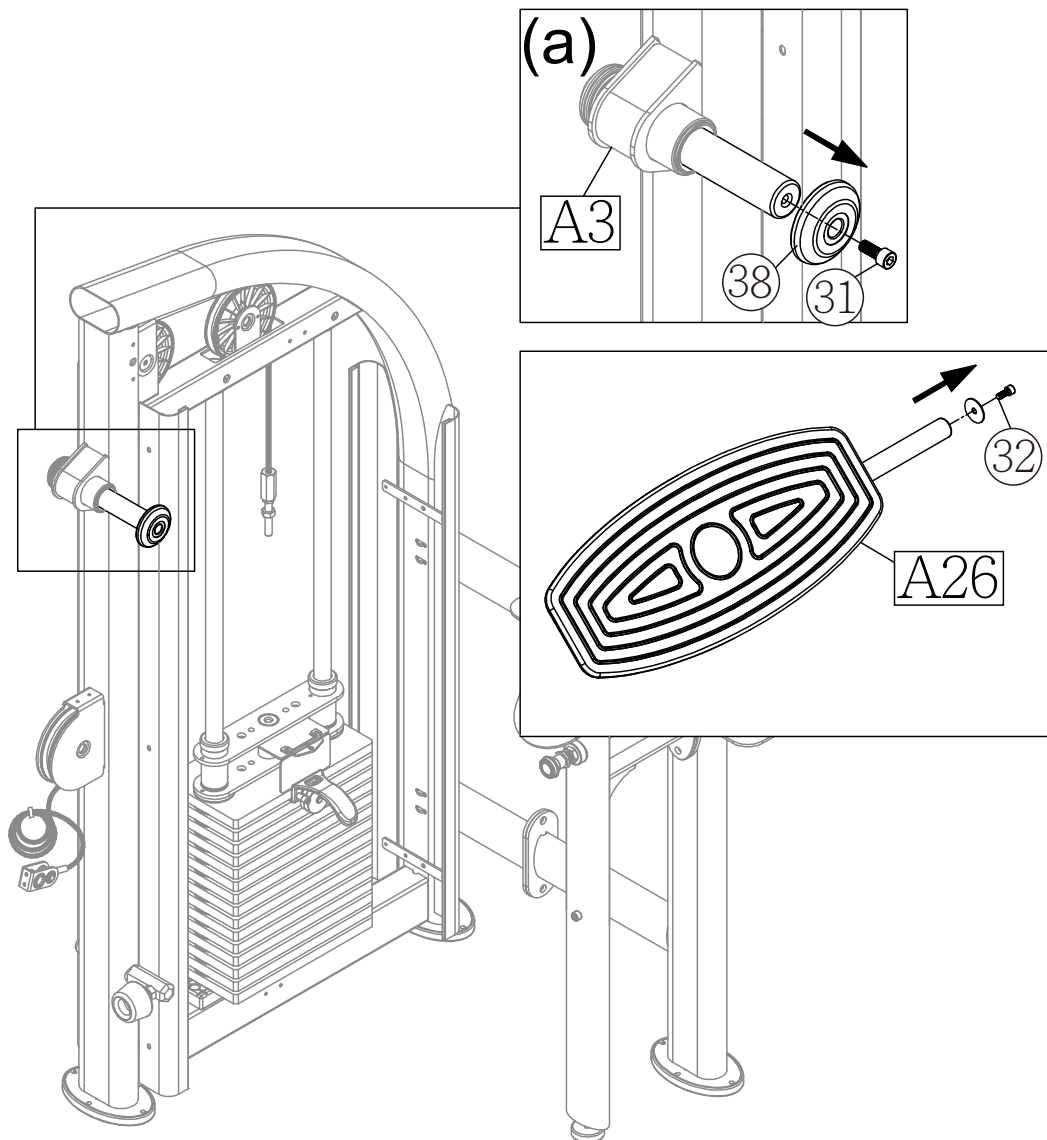

### STEP 3 Foot Swing Rod/Plate & Cable Installation (CONT.)

- (b) Insert the foot swing rod (A25) and the foot swing plate (A26) onto the main frame (A3) and secure with screws (31) (32), the round sticker (17) and the screw soft cap (38).

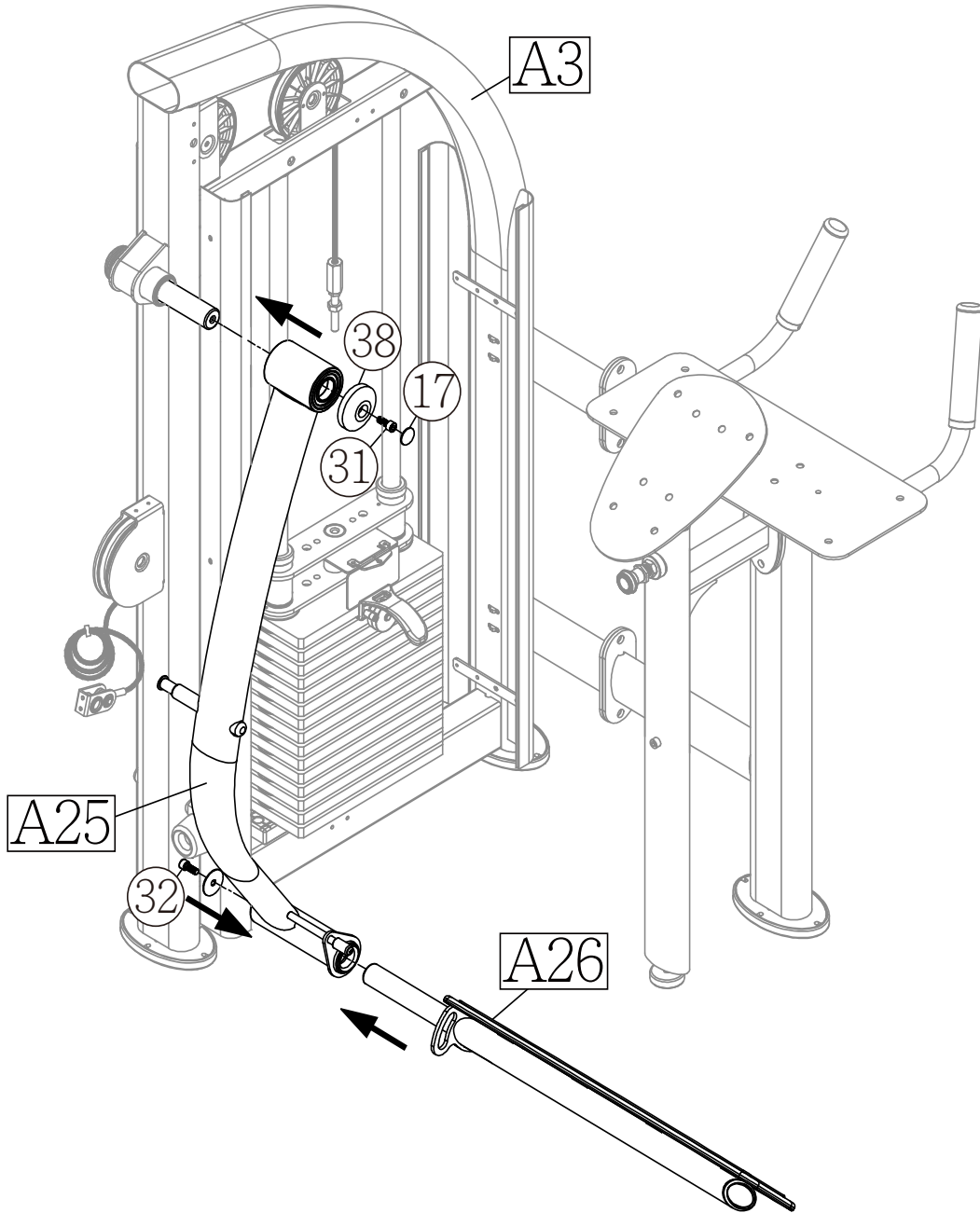

### STEP 3 Foot Swing Rod/Plate & Cable Installation (CONT.)

- (c) Insert the cable nut as indicated by the arrows onto the weight stack rod (A8) at least 15-20mm deep as shown.
- (d) Loosen the cable and Insert the cable set block onto the foot swing rod (A25) and secure the cable set block with screws (41).

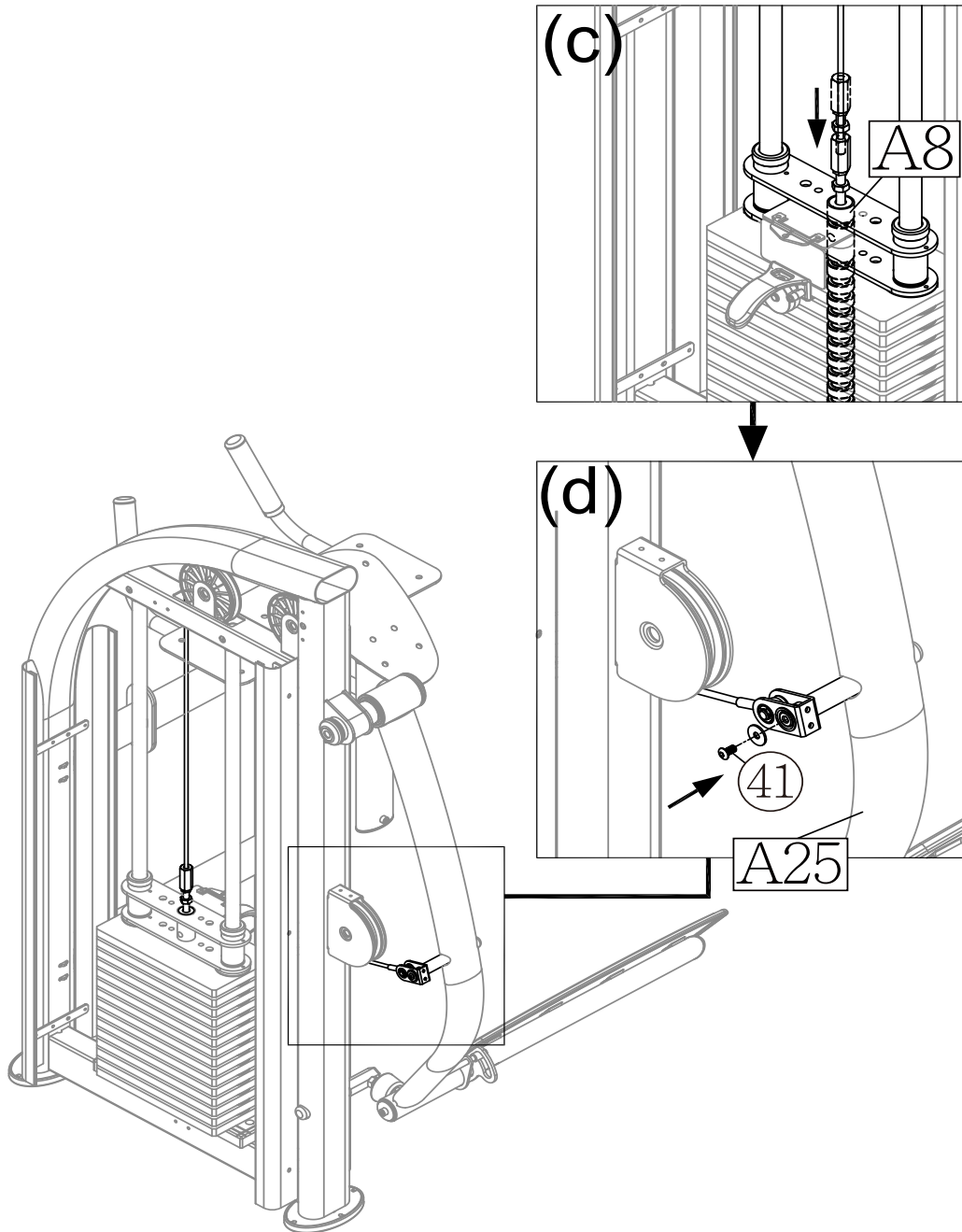

## STEP 4 Chest Cushion Installation

- (a) First, remove screws (37) from the seat back (A21) and the chest cushion (A22) as shown.
- (b) Use screws (37) to secure the seat back (A21) to the seat frame A (A23).
- (c) Use screws (37) to secure the chest cushion (A22) to the seat frame B (A24).

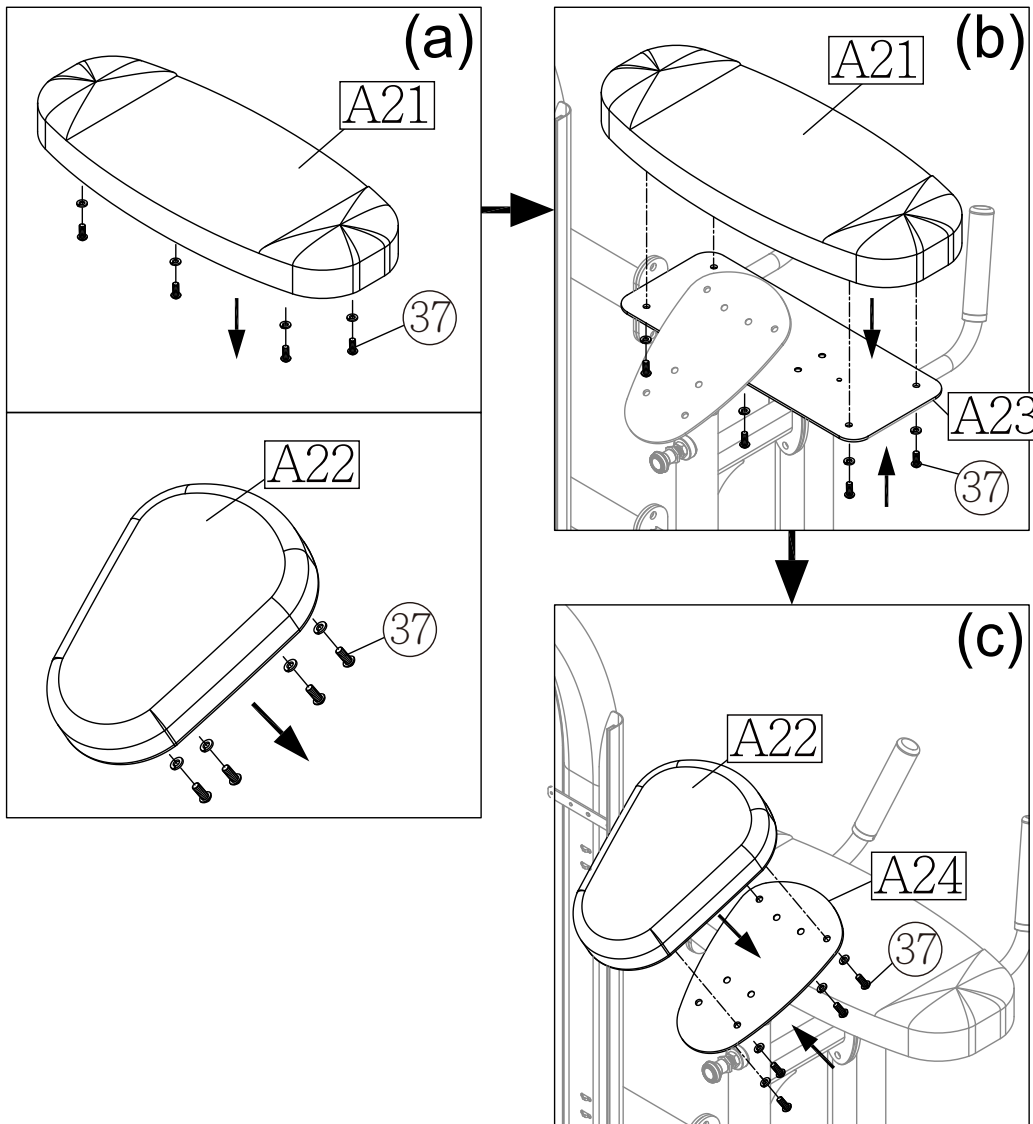

## STEP 5 Apply the Weight Plate Sticker

Note: Before applying weight plate stickers, please wipe the area clean, and clean your hands before proceeding to the next step.

- (a) Align and tape the cardboard to the upper left corner of the weight plate (A30).
- (b) Peel off the top half of the weight plate sticker (A31) backing. Leave the clear outside margin in place on the weight plate sticker. Don't peel off the margin.
- (c) Press the numbered part of the weight plate sticker (A31) in place while you peel off the clear margin of the sticker.
- (d) Peel off the clear margin of the weight plate sticker.
- (e) Follow steps (b through d) to apply the weight plate sticker (A32) to the lower part of the weight stack. When the weight plate stickers are in place, peel off the card board. Press the weight plate sticker in place to ensure good contact on the weight plate.

\*If there are additional optional weight plates, use the optional weight plate stickers.

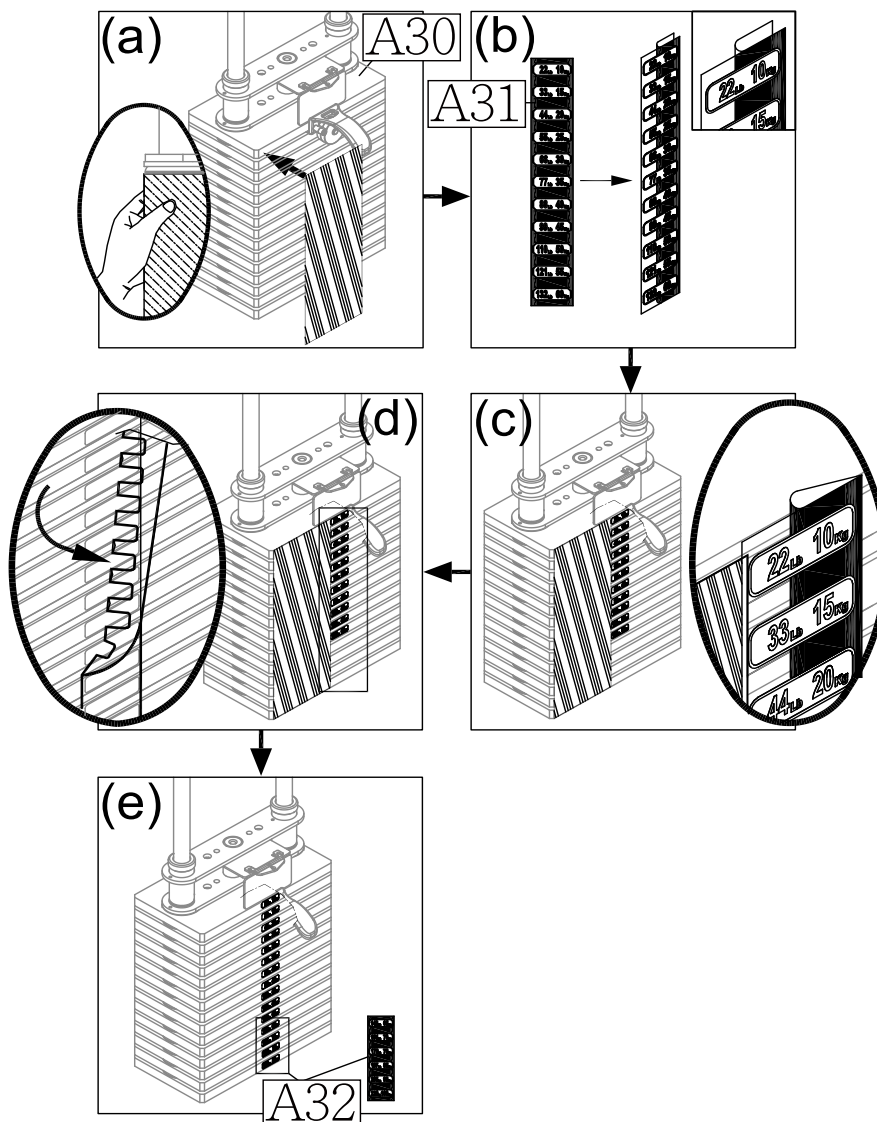

## STEP 6 Install the front and rear covers

(a) Install the square snap bushings (10) to the anchor brackets of shroud (square hole) (A9-1). Secure the anchor brackets of shroud (square hole) (A9-1) with the square snap bushings (10) to the front and back of the upper crossmember assembly of weight stack tower (A3) with screws (11). Secure the anchor brackets of shroud (tapped hole) (A9-2) to the front and back of the lower crossmember assembly of weight stack tower (A3) with screws (11). Remove the screw (46).

(b) Insert the front and rear shrouds (A14, A15) along the plate slot from the top into the main frame.

*(Note: To avoid damage to the shrouds, place the weight selector (A7) on the top weight (33) before inserting the shrouds.)*

(c) Secure the lower shroud with the screw (46).

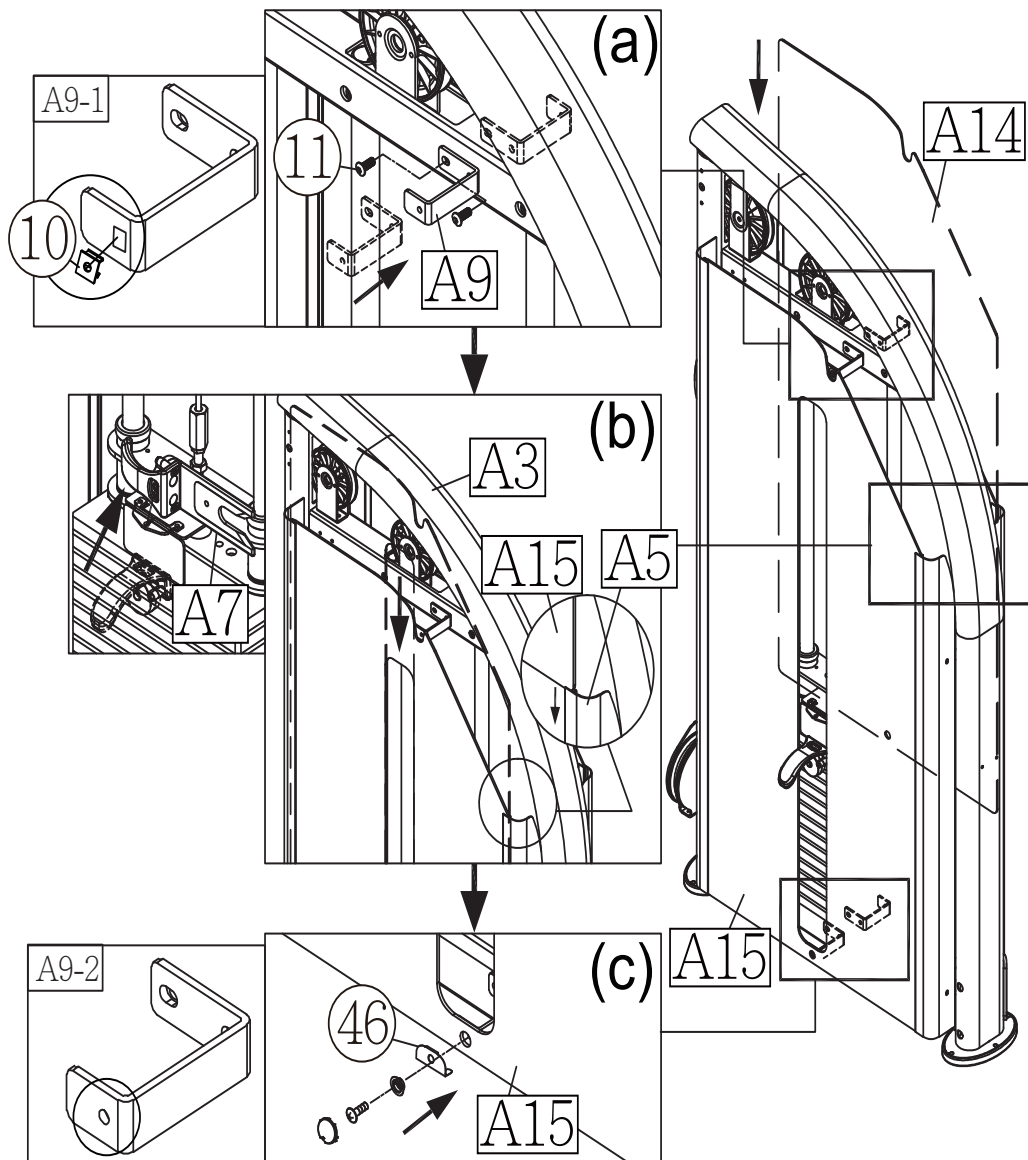

## STEP 7 Install plastic cover

- (a) Install the square snap bushing (10) and fastener (59) to the anchor bracket (A12) and remove the screws (47) on the main frame. Secure the anchor bracket (A12) to the main frame with the screws (47).
- (b) Secure the left/right perforated boards (A1) to the main frame with the screws (21).
- (c) Assemble the right side cover (A2) and the front cover A (A6) together before installing to the main frame.
- (d) Assemble the left side cover (A2) and the front cover A (A6) together and then embed the top cover (A11), which is the water bottle holder, at an oblique angle.
- (e) Secure the top cover (A11) to the main frame with the screws (22) and then install the round screw caps (23).

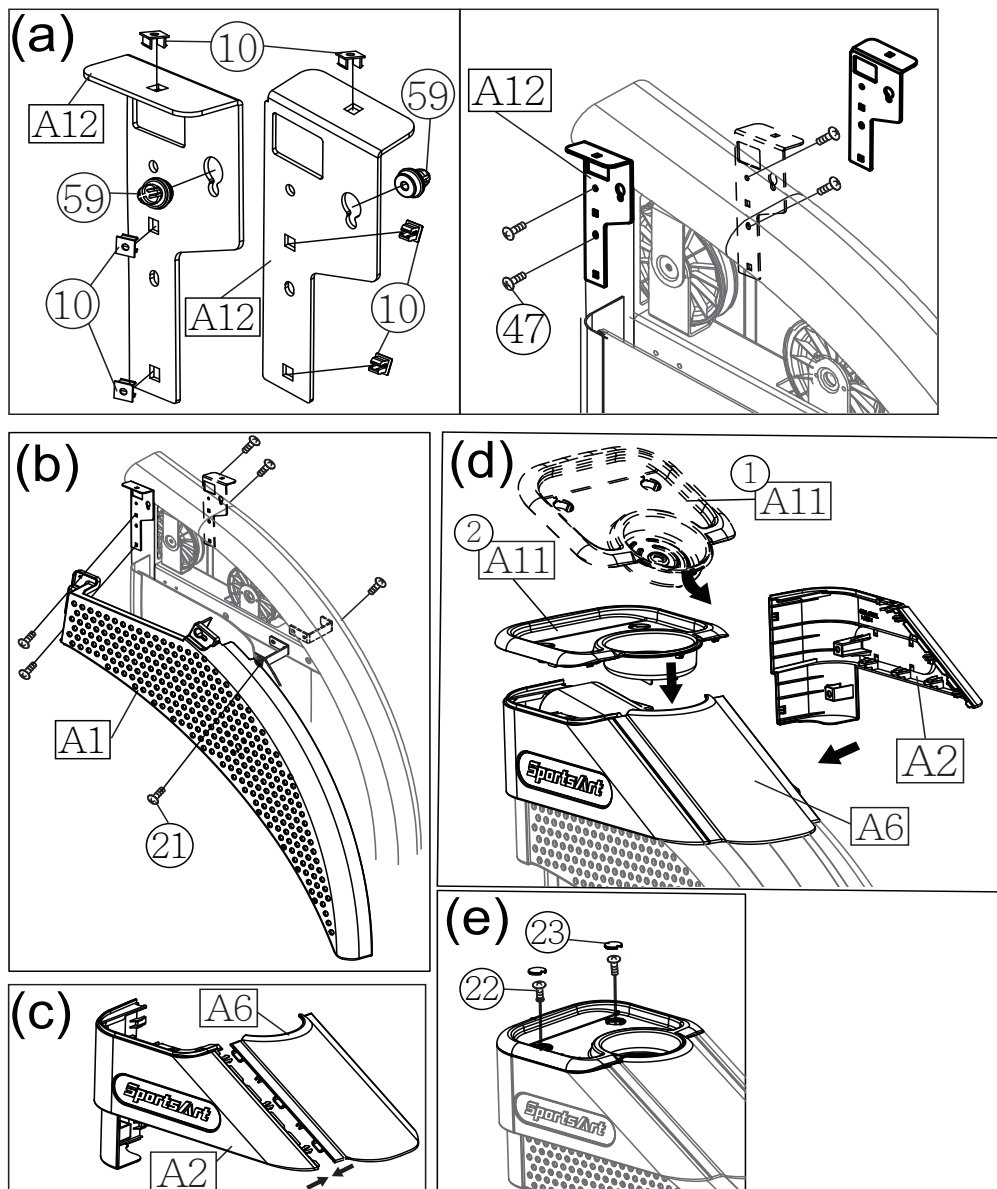

## STEP 8 Install cap nut

Install the cap nuts to the corresponding positions according to the following numbers.

The cap nuts in the following table are for reference only. The provided cap nuts will depend upon the needs of the different devices.

\*The cap nuts in the following table are for reference only. The provided cap nuts will depend upon the needs of the different devices.

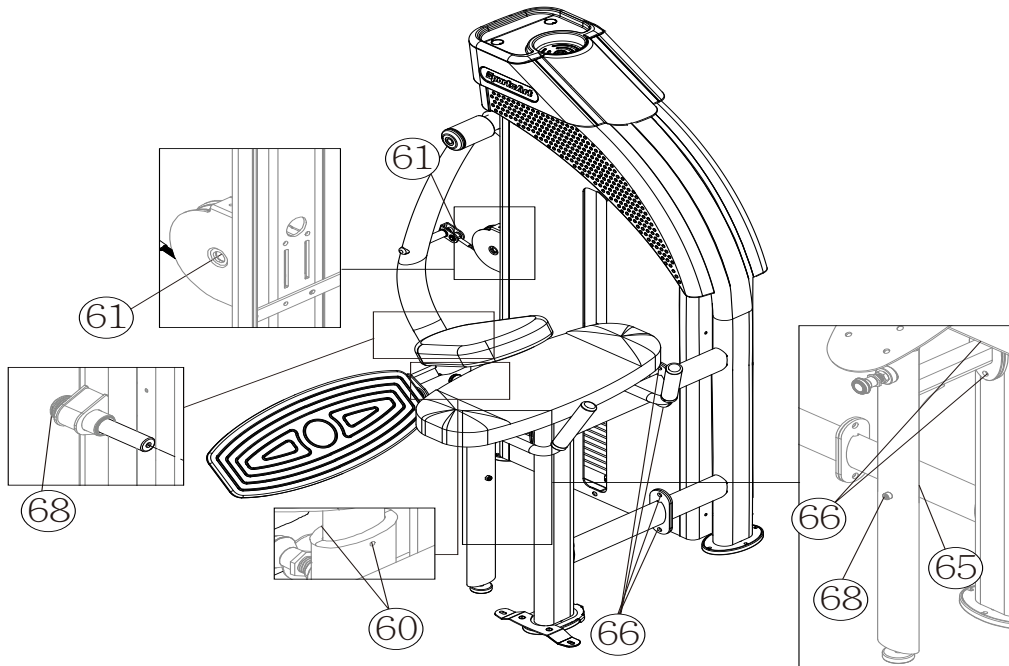

<b>60</b> GBA-P019 	<b>61</b> GBA-P024 	<b>62</b> GBA-P014 	<b>63</b> GFA-P136 	<b>64</b> GBA-P018 
<b>65</b> GBA-P017 	<b>66</b> GBA-P016 	<b>67</b> TAO-P096A 	<b>68</b> GFA-P137 	<b>69</b> GFA-P138 

## STEP 9 Secure the Product

- Remove screws (42) from the floor fixing bracket (A18).
  - Insert the U clip (A19) onto the machine (Make sure the U clip with the correct side downward as shown below), and then secure the floor fixing bracket (A18) with screws (42).
  - Secure the floor fixing bracket to the floor with the floor fixing bolt, nut and washer as shown to make sure the machine is firmly fixed to the floor when operating.
- (Note: The screw hole of floor fixing bracket is  $\varnothing 9\text{mm}$ , please make sure using the suitable floor fixing bolt and drilling the proper hole on the floor.)*

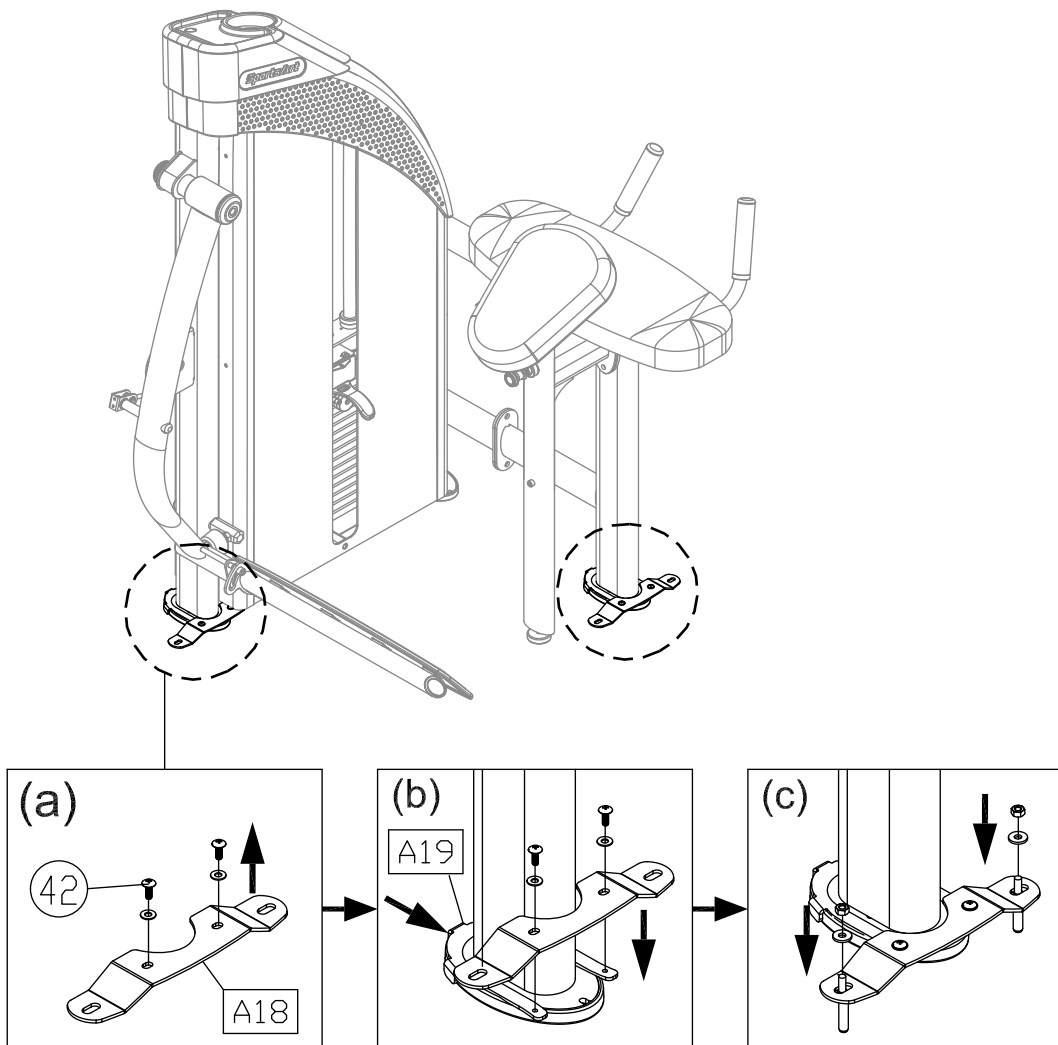

## STEP 10 Cable Adjustment

\* Insert the stack fork into the gap under the lowest weight plate, and then adjust the large nut at area C. Adjust until the upper stack carriage set moves slightly.

To adjust the cable, first insert the (Z) rod and loosen the (Y) nut, and then adjust the (X) nut. If the cable is too long, adjust the (X) nut downward. If too short, adjust the (X) nut upward. After adjusting the (X) nut, tighten the (Y) nut against the weight stack to secure this position.

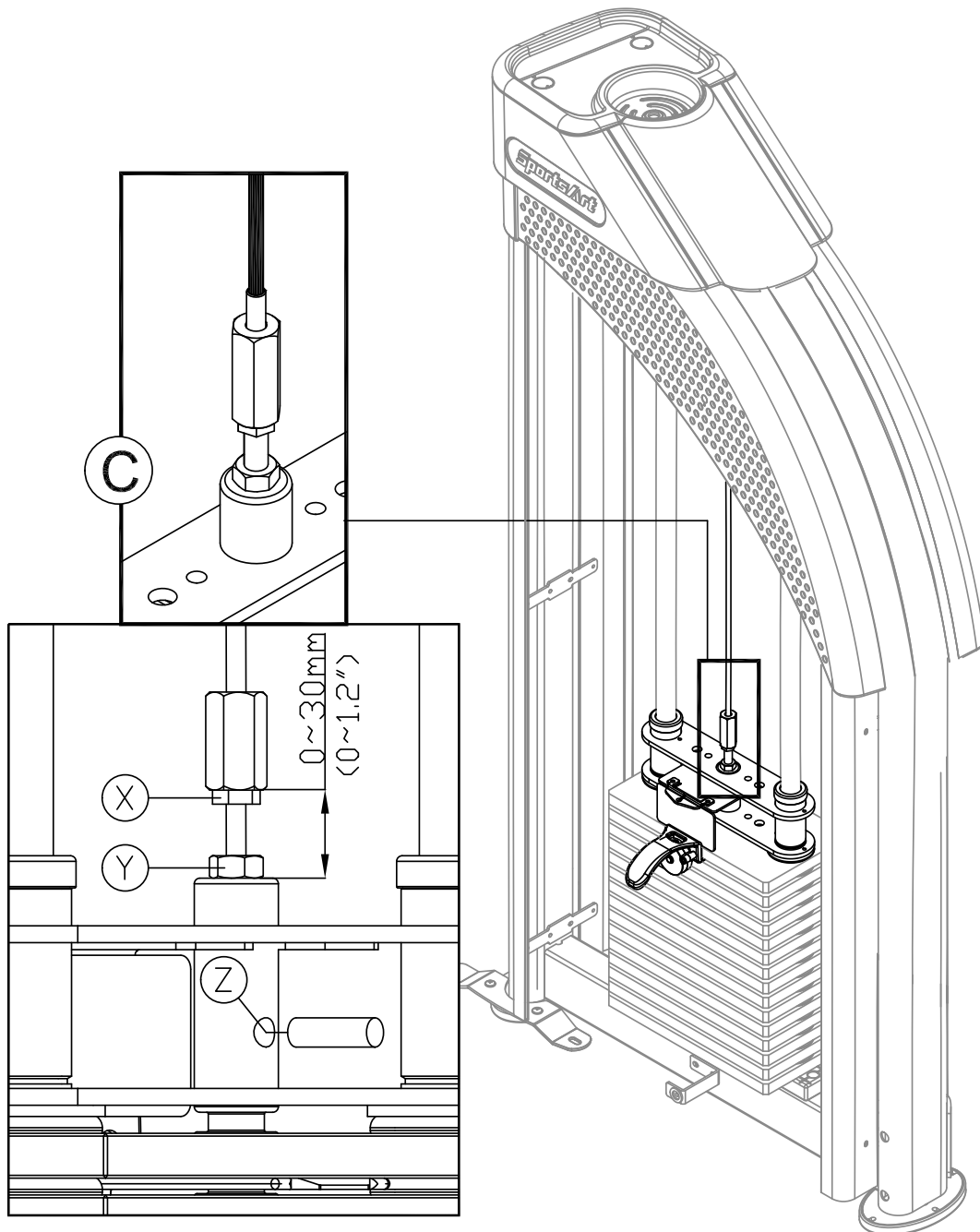

## STEP 11 Stack Fork Inspections

- \* Please follow operating instructions on the product sticker to test operation and confirm that the equipment is working properly.
- \* Insert the stack fork to make sure that every weight plate can be engaged easily.
- \* Insert the stack fork at the heaviest weight setting at which you can safely operate the equipment.
- \* Exercise to lift the stack several times, and then inspect the cable for proper tightness. If necessary, make adjustments according to the instructions "Cable adjustment" of this manual.
- \* Ensure that anyone who is not operator does not near the equipment when testing.

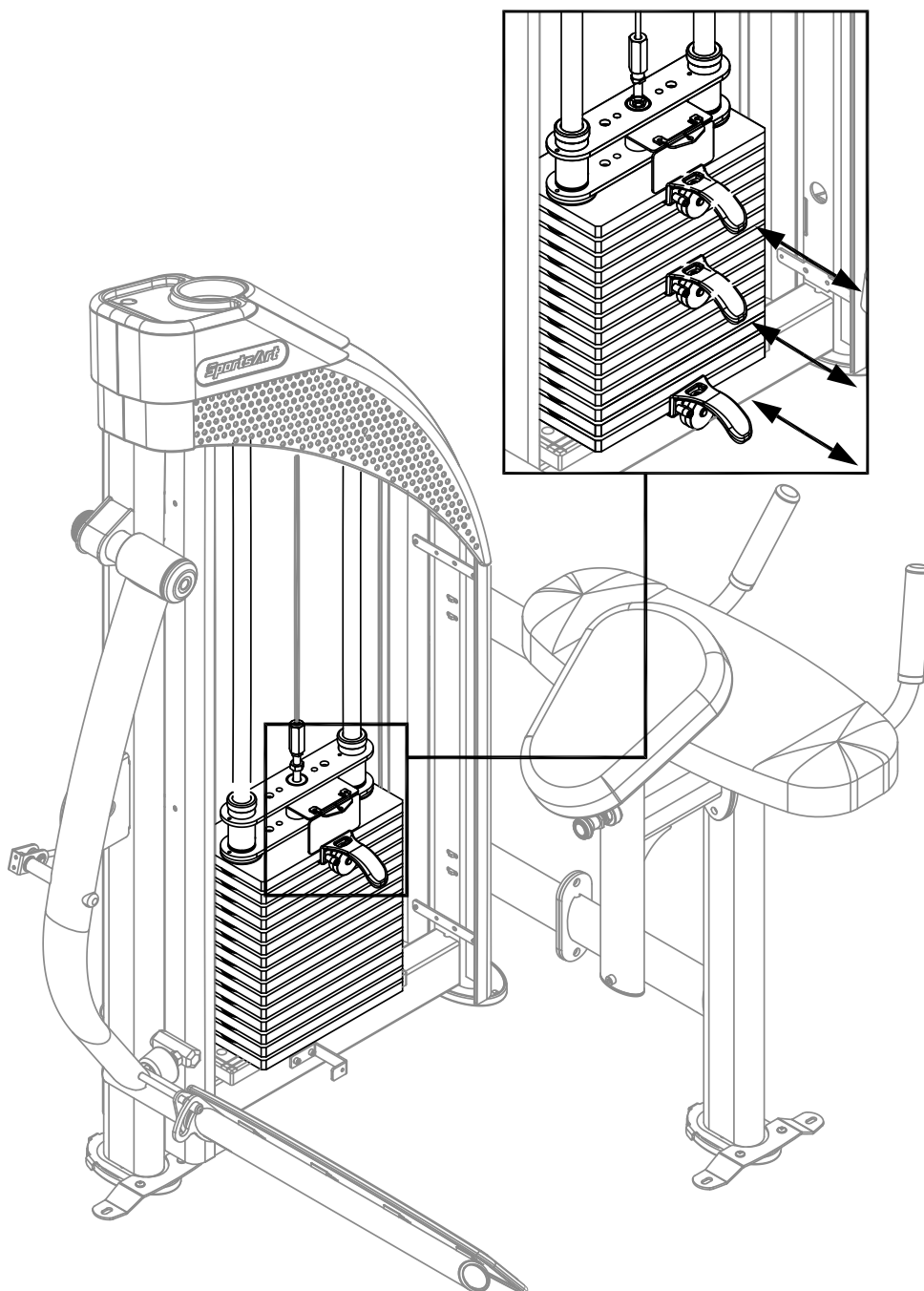

## STEP 12 Level the Product

For the user's safety and the proper functioning of the product, this machine must sit level on a flat floor. If necessary, adjust the levelers by following instructions (a) through (c) below.

- (a) Loosen the leveler nut.
- (b) Rotate the leveler foot downward so it firmly touches the floor.
- (c) To secure this position, secure the leveler nut against the product frame.

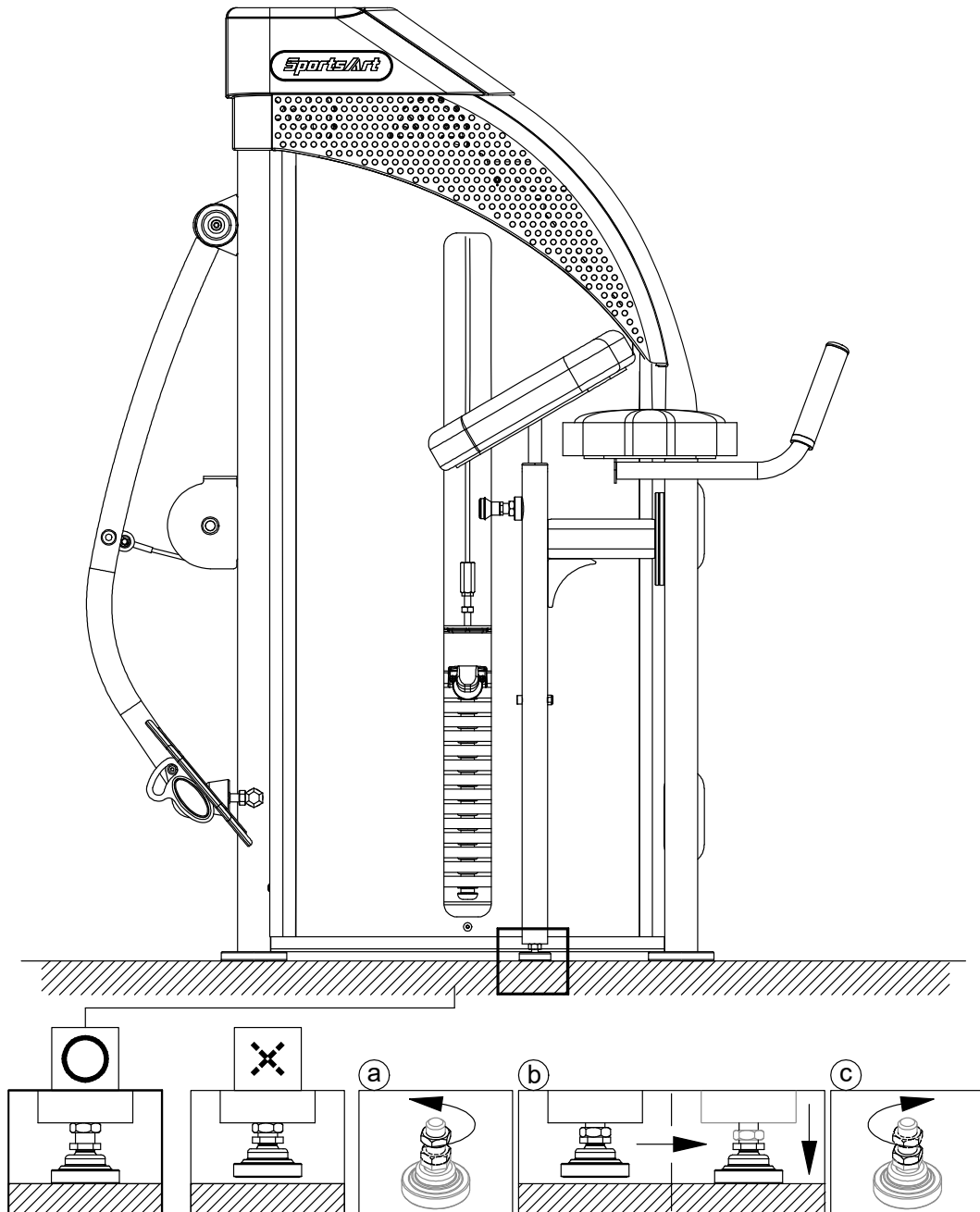

## **STEP 13** Unit Inspection

---

After completing the assembly or regular maintenance, please follow instructions (a) through (c) below to inspect the unit. If the unit is disassembled or has been damaged in any way, it might cause injuries or cause the unit to fail.

- (a) Make sure the unit is steady and on a level surface. If the unit is not steady, make adjustments according to the instructions “Level the Unit” of this manual.
- (b) Make sure all parts are assembled and all fasteners are tightened.
- (c) Please follow operating instructions to test operation and confirm that the equipment is working properly. (Please refer to “Operate the Product” of this manual.)

## 5. OPERATION THE PRODUCT

### OPERATION Safety Operating Area

- (a) Make sure operate the unit in safety area as shown. Do not allow people to be near this area when operating.
- (b) Noise emission under load is higher than without load.
- (c) Over exercising or improper workout position may result in serious injury.
- (d) This product is intended for exercise glute.

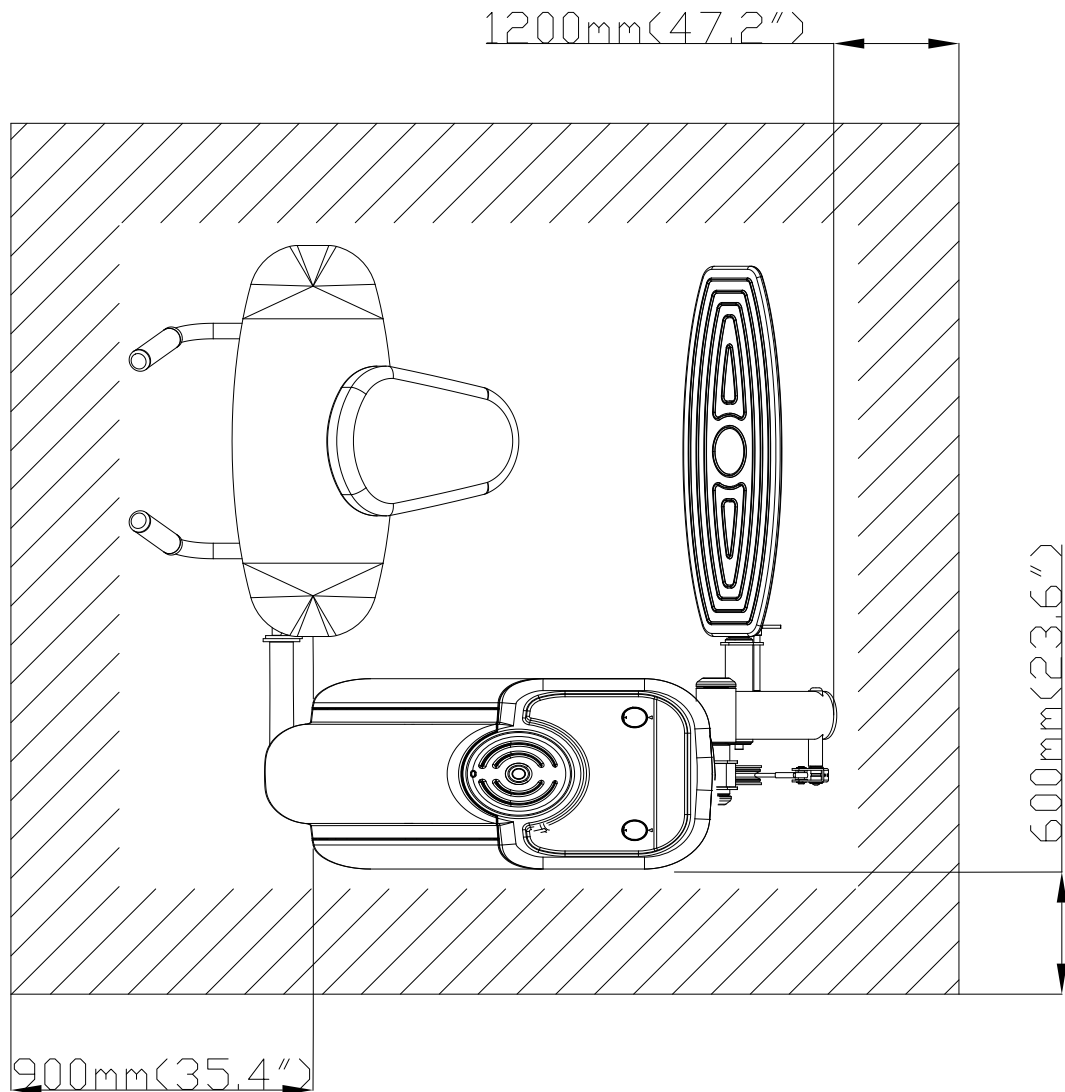

## **OPERATION** Exercising Instructions

- (a) Select the appropriate weight plates according to your recommended exercise level.
- (b) Adjust the seat height to the most comfortable position and make sure the knob is engaged to secure the position.
- (c) Perform the exercise in a controlled manner. Inhale when pushing up against resistance and exhale when returning to original position.
- \* Please exercise within the range of your skill and training. DO NOT work to exhaustion.
- \* All users operate this machine must be supervised under coaches instructions at all times in order for safety.

Please follow the operating instructions as below to test operation.

- (a) Please follow operating instructions on the product sticker to test operation and make sure the equipment is working properly.
- (b) Insert the stack fork at the heaviest weight setting at which you can safely operate the equipment. Exercise to lift the stack several times. Then inspect the cable for proper tightness. If necessary, make adjustments according to the instructions in this manual.

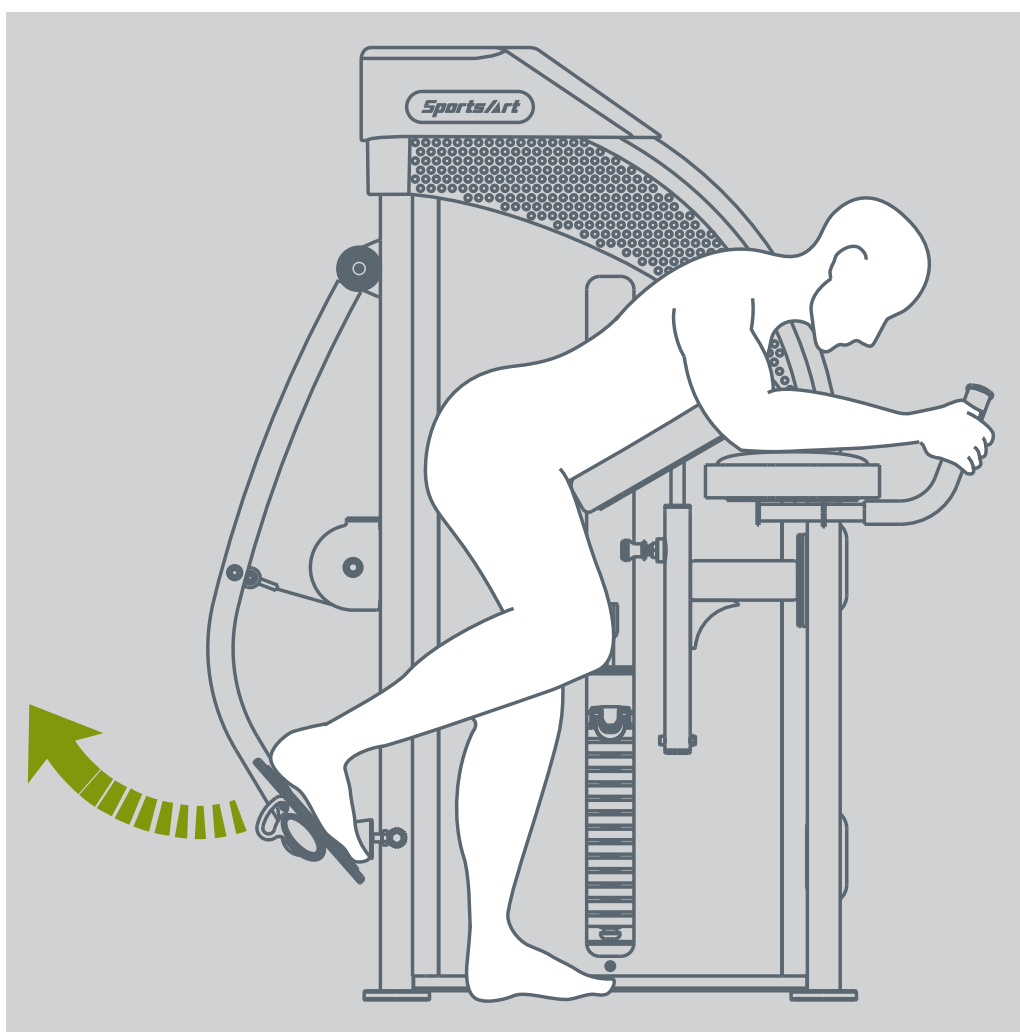

## **OPERATION** Exercising Instructions (CONT.)

\* Chest cushion height positioning can be adjusted. Simply, put out the related knob, make the adjustment, and release the knob to secure the desired position.

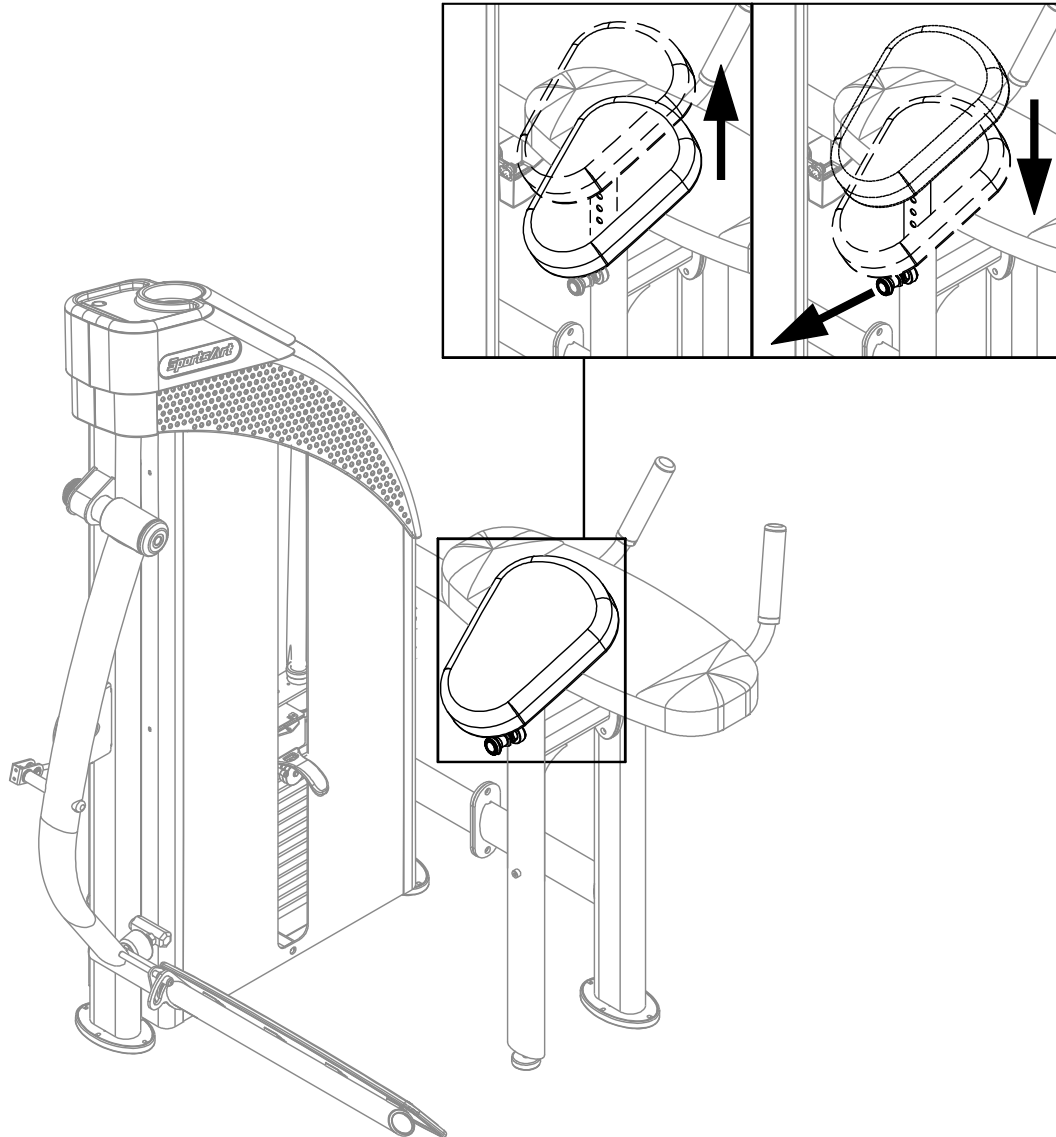

## **6. MAINTENANCE**

This section covers maintenance topics and includes a maintenance schedule, task list, and log.

### **MAINTENANCE** Safety Precautions

---

- Please follow standard safety precautions when servicing this product.
- Do NOT use a water damp towel to clean the product and do perform the following maintenances.
- Do NOT use cleaners with alcohol, ammonia, or other damaging chemicals. The use of such chemicals can damage the product and void the warranty. Never spray or pour any liquid directly onto the product. Doing so can damage components and void the warranty.
- Use a clean, lint-free towel, dampened with a mixture of Simple Green® all-purpose cleaner, to thoroughly clean the handlebar and the console.
- This product has moving parts that can be hazardous. Exercise caution when maintaining, operating, or moving this product.
- Do not use accessories or parts that are not specifically recommended by the manufacturer (SportsArt) . Such parts might cause injuries or cause the unit to fail and void the warranty. We are not responsible for any safety issue that arises due to the misuse of accessories or parts. At the same time, we will terminate the warranty terms of this equipment.
- Maintenance and repair must be performed by trained service personnel only. Improper maintenance would not only damage the machine, but may also present a danger to the exerciser.
- Keep this product out of use until maintenance is completed.

## **MAINTENANCE** Guide Rod Cleaning and Lubricating

1. Apply lubricant to the guide rods every week.

Procedure:

- (a) Put some lubricant on a clean, lint-free cloth. Rub the lubricated cloth on the guide rods.
  - (b) Load the upper stack carriage set. Exercise to test operation.
  - (c) Repeat steps (a) and (b) 2-3 times. (Note: the cloth should be lint-free.)
2. After lubricating the guide rods, inspect cable tightness. Refer to the manual, and adjust it if necessary.

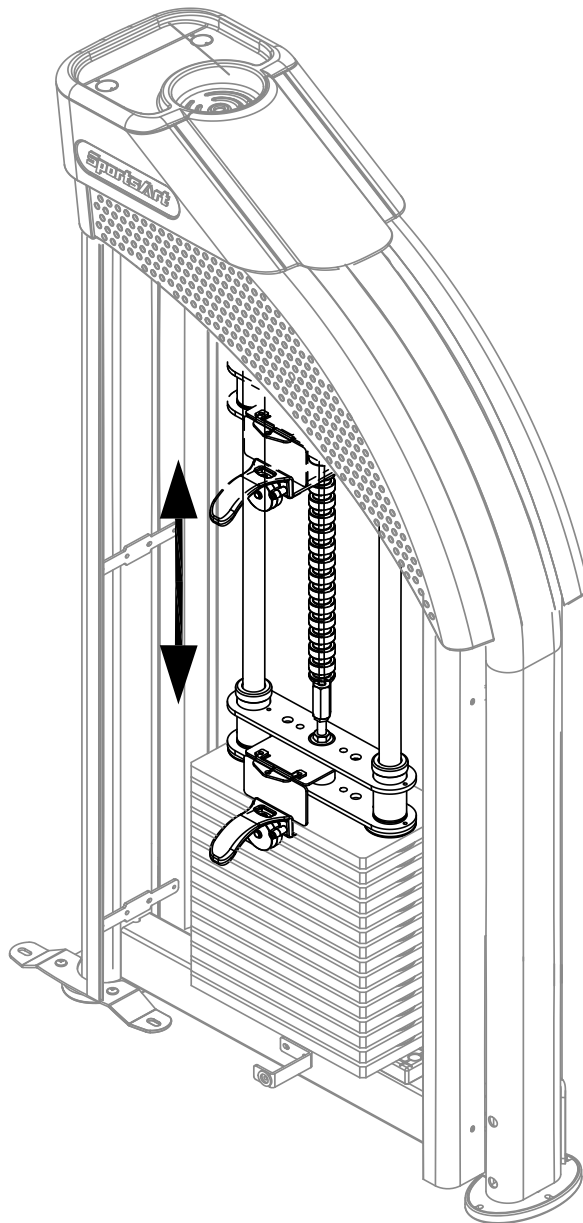
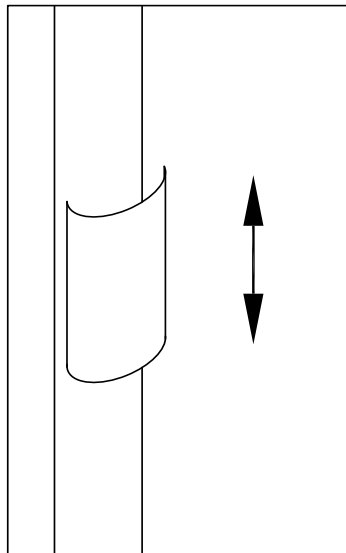
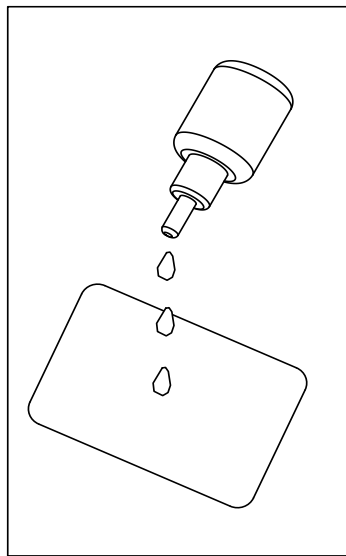

## **MAINTENANCE** Schedule

If there is a need for maintenance of components, please visit the SportsArt website.

cleaning requirements

1.directive 93/42/CEE

2.directive biocide 98/8/CEE

The disinfectant has to be in compliance with Medical Device Directive 93/42/EEC (MDD) and Biocidal Products Directive 98/8/EC (BPD).

It is suited for sensitive synthetic surfaces such as synthetic leather, polycarbonate (PC), acrylic glass and polysulfone, and for the keyboards and control panels.

	Area	Day	Week	Month	Quarter	Year	Notes
1	Exterior	●					Clean.
2	Screws	●					Inspect for looseness and secure if necessary.
3	Test	●					Check for proper equipment operation.
4	Seat back/ bottom	●					Use damp cloth to clean.
5	Cable		●				Check for damage or wear. Replace it if necessary.
6	Guide Rod		●				Clean and lubricate.
7	Extension tube		●				Clean and lubricate.

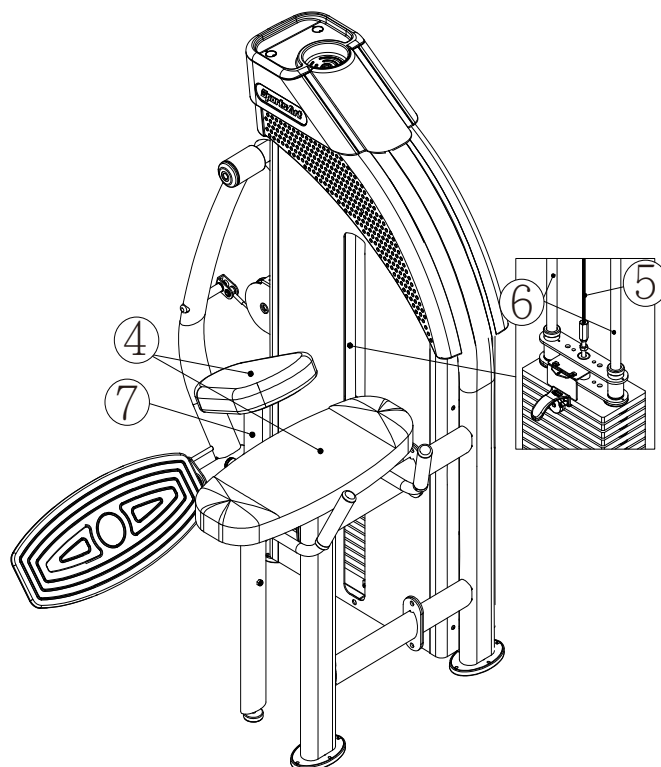

## **MAINTENANCE** Task List

---

Like cars, fitness products require maintenance. Regular maintenance extends product life, and failure to maintain products can void the manufacturer's warranty. Copy the maintenance log sheet, and record maintenance work for each fitness product.

### **Daily tasks**

1. Use a clean, lint-free towel to wipe down the product exterior.
2. Inspect all screws. Secure if necessary.
3. Make sure the machine is working properly.
4. Wipe the seat bottom and the seat back clean with a damp cloth.

### **Weekly tasks**

1. Check the cable for damage or tear.
2. Clean and lubricate the guide rods.
3. Clean and lubricate the extension tube.

### **Caution**

- Please follow standard safety precautions when servicing this product.
- Do NOT use cleaners with alcohol, ammonia, or other damaging chemicals. The use of such chemicals can damage the product and void the warranty. Never spray or pour any liquid directly onto the product. Doing so can damage components and void the warranty.

## **MAINTENANCE** One-Year Maintenance Log

Facility: \_\_\_\_\_ Supervisor: \_\_\_\_\_

Product model number: \_\_\_\_\_ Serial number: \_\_\_\_\_

Start date: \_\_\_\_\_ End date: \_\_\_\_\_

Daily Tasks	Weeks 1-7	Weeks 8-14	Weeks 15-21	Week 22-28
Completed	<input type="checkbox"/>	<input type="checkbox"/>	<input type="checkbox"/>	<input type="checkbox"/>

Daily Tasks	Week 29-35	Week 36-42	Week 43-49	Week 50-52
Completed	<input type="checkbox"/>	<input type="checkbox"/>	<input type="checkbox"/>	<input type="checkbox"/>

Weekly Tasks	Weeks 1-7	Weeks 8-14	Weeks 15-21	Weeks 22-28
Completed	<input type="checkbox"/>	<input type="checkbox"/>	<input type="checkbox"/>	<input type="checkbox"/>

Weekly Tasks	Weeks 29-35	Weeks 35-42	Weeks 43-49	Weeks 50-52
Completed	<input type="checkbox"/>	<input type="checkbox"/>	<input type="checkbox"/>	<input type="checkbox"/>

Monthly tasks	1	2	3	4	5	6	7	8	9	10	11	12
Completed	<input type="checkbox"/>	<input type="checkbox"/>	<input type="checkbox"/>	<input type="checkbox"/>	<input type="checkbox"/>	<input type="checkbox"/>	<input type="checkbox"/>	<input type="checkbox"/>	<input type="checkbox"/>	<input type="checkbox"/>	<input type="checkbox"/>	<input type="checkbox"/>

Quarterly Tasks	Quarter 1	Quarter 2	Quarter 3	Quarter 4
Completed	<input type="checkbox"/>	<input type="checkbox"/>	<input type="checkbox"/>	<input type="checkbox"/>

Yearly Tasks	Year 1
Completed	<input type="checkbox"/>

Notes: \_\_\_\_\_

\_\_\_\_\_

\_\_\_\_\_

\_\_\_\_\_

## **7. CONSIGNES DE SÉCURITÉ IMPORTANTES**

Le produit SportsArt a été conçu et fabriqué afin d'assurer une sécurité optimale. Cependant certaines précautions s'appliquent chaque fois que vous utilisez votre produit.

- Lisez entièrement le manuel avant l'assemblage et l'utilisation. Veuillez aussi noter les consignes de sécurité suivantes:
- Veuillez lire attentivement les instructions et installer le produit selon les instructions.
- Assemblez et faites fonctionner le produit sur une surface solide et plane; NE PAS l'utiliser à l'extérieur ou près de l'eau.
- En aucun cas, ne laissez des enfants à proximité ou sur le produit.
- Vérifiez le tapis de course avant chaque utilisation. Assurez-vous que toutes les pièces sont assemblées et que tous les éléments de fixation sont serrés. NE PAS utiliser le produit si l'appareil est démonté de quelque façon.
- Gardez vos mains loin des pièces mobiles.
- Portez des vêtements d'entraînement appropriés; NE PORTEZ PAS de vêtements amples. NE PORTEZ PAS de chaussures à semelles en cuir ou à talons hauts. Attachez les cheveux longs.
- Soyez prudent lors du montage et démontage de l'appareil.
- NE PAS utiliser d'accessoire non spécifiquement recommandé par le fabricant. Car cela pourraient provoquer des blessures ou entraîner une panne de l'appareil.
- Débranchez l'appareil de la prise avant l'entretien ou la suppression de toute pièce.
- Une surveillance étroite est nécessaire quand de produit est utilisé par ou à proximité d'enfants, de malades ou de personnes handicapées.
- Utilisez ce produit uniquement pour l'usage prévu dans ce manuel.
- La limite de poids de l'utilisateur pour le produit est de 227 kg, 500 lb.
- Ce produit n'est pas destiné à être utilisé par des personnes (y compris des enfants) dont les capacités physiques, sensorielles ou mentales sont réduites ou qui ne disposent pas de l'expérience ou du savoir nécessaires, sauf si celles-ci ont au préalable été formées eu égard à l'utilisation de produit par une personne responsable de leur sécurité.
- Les enfants doivent être encadrés afin d'empêcher qu'ils ne jouent avec le produit.

### **ATTENTION**

Si vous ressentez une douleur ou si vous avez une sensation anormale, **ARRÊTEZ VOTRE ENTRAÎNEMENT** et consultez immédiatement votre médecin. Entraînez-vous à votre niveau d'exercice recommandé. NE PAS s'entraîner jusqu'à l'épuisement. Avant de commencer un programme d'exercice, vous devriez consulter votre médecin. Il est recommandé de faire un examen physique complet. Dans ce manuel, les mots "gauche" et "droit" sont utilisés en référence aux pièces et au produit. Comme tels, les mots "gauche" et "droit" font respectivement référence aux côtés gauche et droit de l'exerciseur. De même pour plus de concision, le mot «vis» est utilisé dans certains cas où des rondelles, des vis et autres matériels sont associés.

## 8. APPENDIXES

### APPENDIXES

# P855 Glute

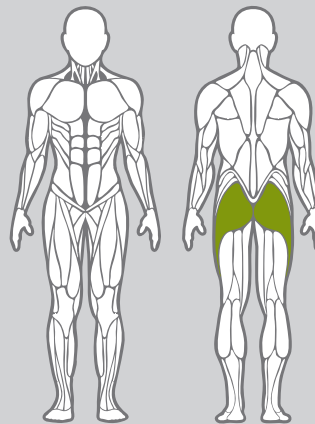
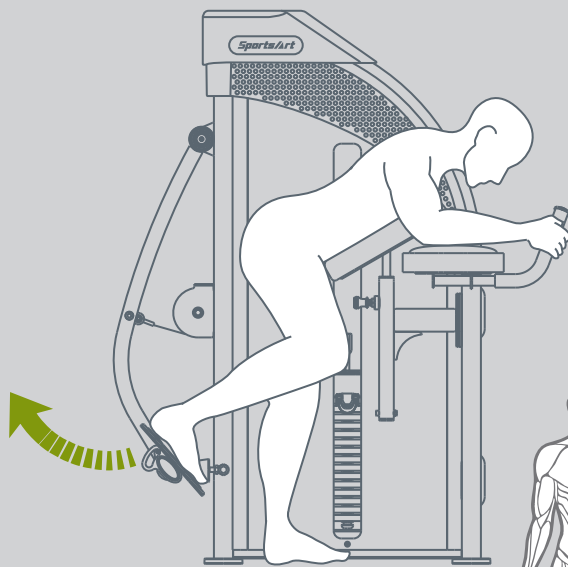

- 1 Select a resistance level that enables you to perform the movement correctly.
- 2 Bend your upper body forward against pad.
- 3 Place elbows on lower pad while grasping handles.
- 4 Bend knee to a 45° angle. Push leg backwards and up, placing foot against push plate.
- 5 Maintain pelvis in a fixed position.
- 6 Perform the exercise in a controlled manner. Exhale when pushing against resistance.

[www.sportsartfitness.com](http://www.sportsartfitness.com)

#### CAUTION

Do not use this machine if you are unfamiliar or do not know how to operate it. Do not allow people near this machine when in use. Keep clear of parts not intended for contact during exercise. For your safety, exhale while you exert force.

**Your Authorized Distributor**