

P857 OWNER'S MANUAL CONTENTS

1. INTRODUCTION	2
2. SAFETY PRECAUTIONS	3
3. LIST OF PARTS	4
4. ASSEMBLE THE PRODUCT	9
STEP 1 Cover Support Plate and the Connector Installation.....	9
STEP 2 Weight Stack Installation.....	13
STEP 3 Cam Installation.....	17
STEP 4 Cable Installation.....	19
STEP 5 Handle Installation.....	23
STEP 6 Cylindrical Cushion Arm Installation.....	24
STEP 7 Seat Bottom and Cylindrical Cushion Installation.....	25
STEP 8 Apply the Weight Stack Sticker.....	27
STEP 9 Front Cover and the Rear Cover Installation	28
STEP 10 Install plastic cover	31
STEP 11 Install cap nut	32
STEP 12 Secure the Product	33
STEP 13 Level the Product.....	34
STEP 14 Cable Adjustment.....	35
STEP 15 Stack Fork Inspections.....	36
STEP 16 Unit Inspection.....	37
5. OPERATION INSTRUCTION	38
OPERATION Safety Operating Area	38
OPERATION Exercising Instructions	39
6. MAINTENANCE	43
MAINTENANCE Safety Precautions	43
MAINTENANCE Guide Rod Cleaning and Lubricating	44
MAINTENANCE Schedule	45
MAINTENANCE Task List	46
MAINTENANCE One-Year Maintenance Log	47
7. CONSIGNES DE SÉCURITÉ IMPORTANTES	48
8. APPENDIXES	49
APPENDIXES Optional accessories	49

Disclaimer

The information in this user manual is subject to change without prior notice.

Sports Art Industrial Co., Ltd. makes no representation or warranty of any kind, express or implied, regarding the marketability of this manual, the suitability for a special purpose, or any other matters.

SportsArt Industrial Co., Ltd. accepts no responsibility for any errors in this manual, or any damages incurred directly, indirectly, accidentally, or continually from the modification, display, or other use of this manual.

*We reserve the right to revise this manual at any time without notice.

1. INTRODUCTION

Congratulations on the purchase of a high quality SportsArt product, the P857 machine. Constructed of high quality materials and designed for years of reliable performance, this product was made for full commercial use.

Before this product is assembled or operated, we recommend that you familiarize yourself with this manual. Understanding the correct assembly and operation of this product will help ensure that exercisers obtain their fitness goals safely and successfully.

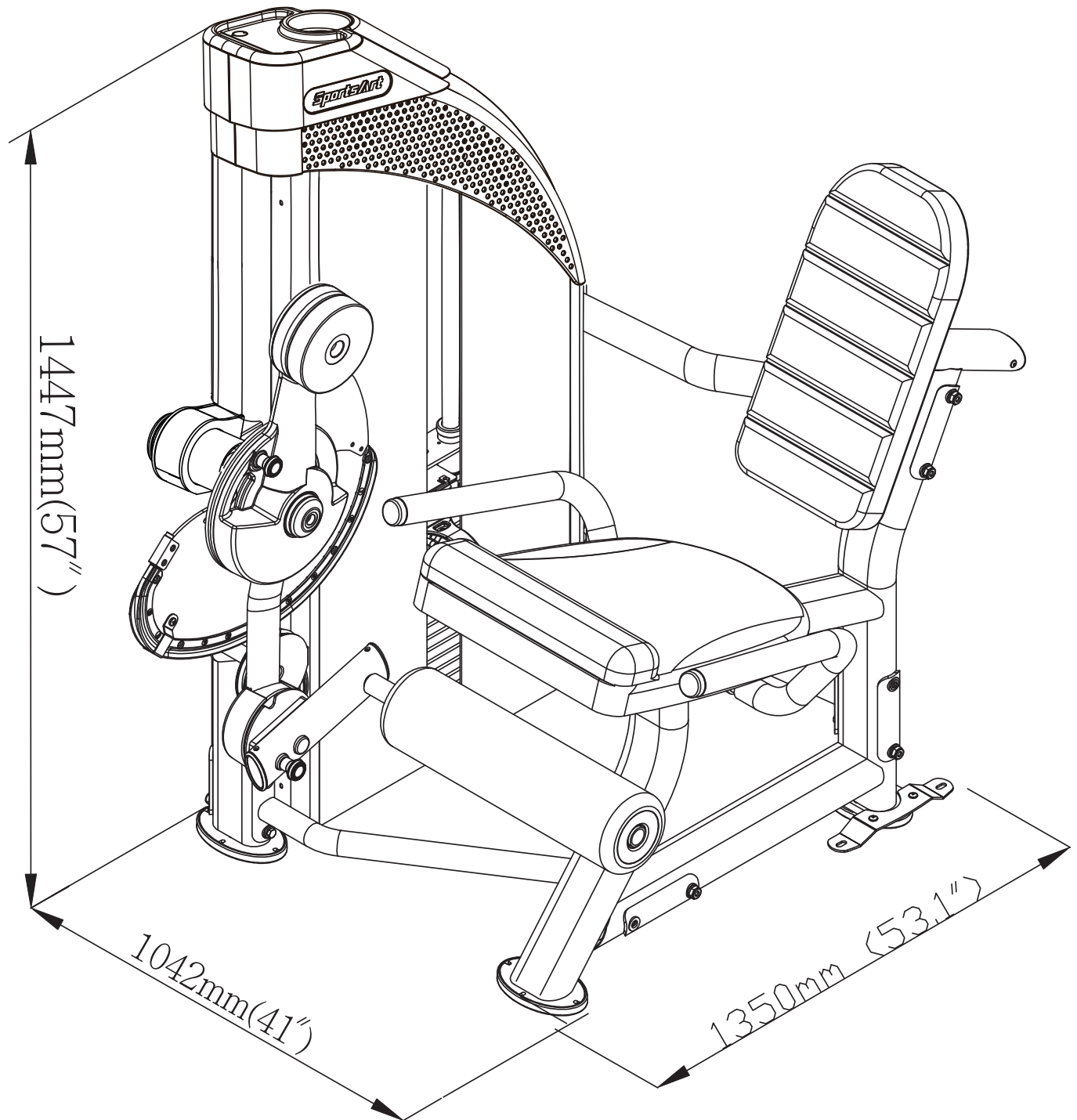

2. SAFETY PRECAUTIONS

This product was designed and built for optimum safety. However certain precautions apply during the use of this product. Please note the following safety precautions:

- Please read the entire manual before assembly and operation. Make sure the product is installed and operated as instructed in this manual.
- Assemble and operate the product on a solid, level surface. Do not use outdoors or near water, including pools and saunas.
- Check the product before every use. Make sure all parts are assembled, and all fasteners are tightened. Do not use the product if it is disassembled in any way.
- Wear proper workout clothing. Do not wear loose clothing. Do not wear shoes with leather soles or high heels. Tie all long hair back. Do not go barefoot on this product.
- Keep away from moving parts. Moving parts may or may not stop immediately if an object becomes caught or impedes normal motion.
- Use this product only for its intended purpose as described in this manual.
- Be careful when mounting and dismounting the unit.
- Never operate this product if it has been damaged in any way. If it is not working properly, or has been dropped or damaged, contact a service technician for repairs.
- Do not use accessories or parts that are not specifically recommended by the manufacturer (SportsArt). Such parts might cause injuries or cause the unit to fail and void the warranty. We are not responsible for any safety issue that arises due to the misuse of accessories or parts. At the same time, we will terminate the warranty terms of this equipment.
- This product is not intended for use by persons (including children 14 or younger) with reduced physical, sensory, or mental capabilities, or by people who are otherwise deficient in product knowledge or experience. If such people use this product, they should be given training and be supervised at all times by someone responsible for their safety.
- Contact your SportsArt representatives on all materials damaged in shipment. (Note: Shipping damages are the responsibility of the carrier.)
- Unpack and verify contents of boxes according to the list of parts to check if any parts are missing.
- Children 14 or younger should be supervised to ensure that they do not play on or near the product.
- The user weight limit for this product is 227 kg, 500 lb.
- Maintenance and repair must be performed by trained service personnel only. Improper maintenance would not only damage the machine, but may also present a danger to the exerciser.
- Over exercise may result in serious injury or death
- Warning that any of the adjustment devices that could interfere with the user's movement should not be left projecting.

CAUTION: If you feel any pain or any abnormal sensations, **STOP YOUR WORKOUT** and consult your physician immediately. Work within your recommended exercise level. **DO NOT** work to exhaustion. Before beginning any exercise program, you should consult with your doctor. It is recommended that you undergo a complete physical examination.

*NOTE: Each machine provides a different resistance ratio of weight stack.

3. LIST OF PARTS

Box A

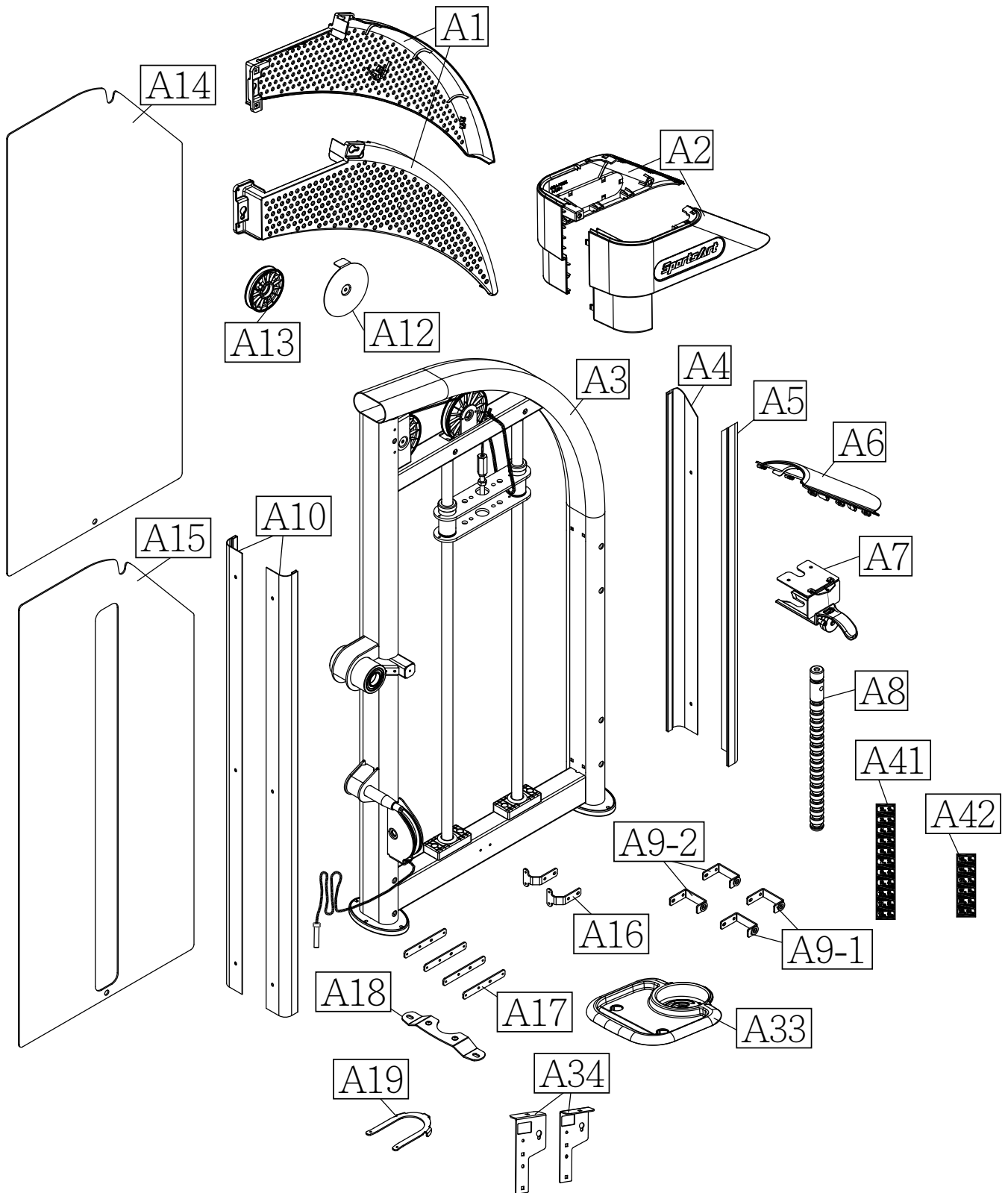

Box B

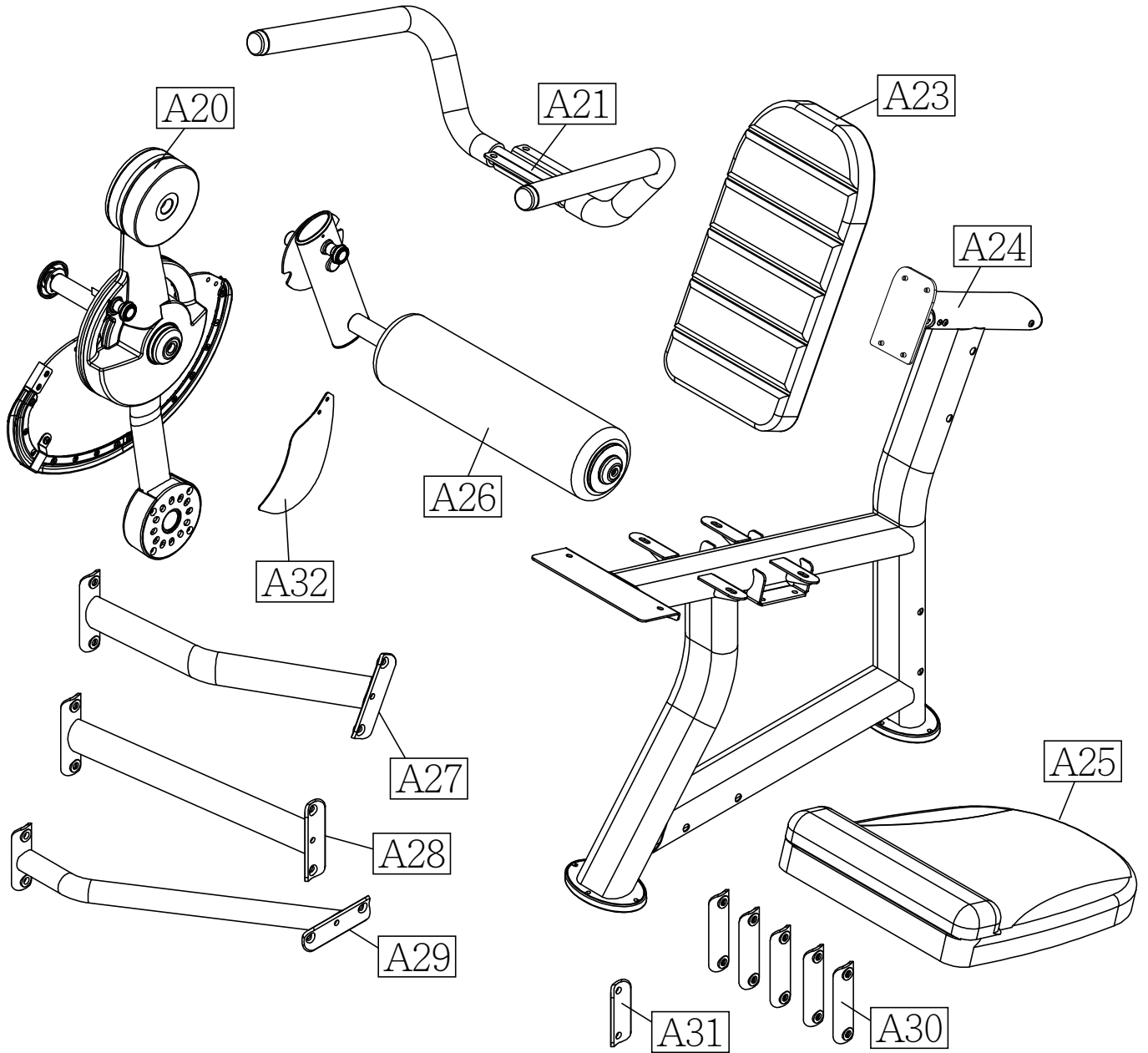

Box C +Box D

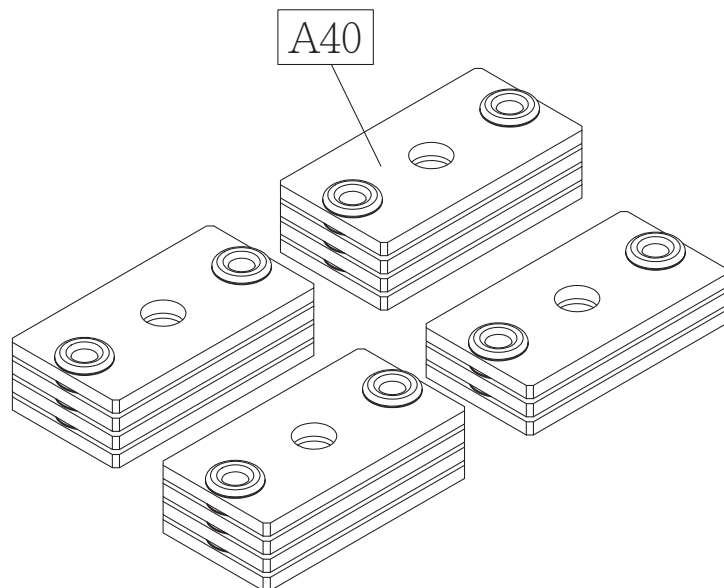

Box A - Main Frame Components					
No.	Name	Qty.	No.	Name	Qty.
A1	Left/right perforated boards	2	A11	Cover support plate A	1
A2	Left/right side cover	2	A12	Pulley cover	1
A3	Main frame	1	A13	Pulley	1
A4	Cover support plate B-2	1	A14	Rear cover	1
A5	Cover support plate B-1	1	A15	Front cover	1
A6	Front cover A	1	A16	Bracket	2
A7	Stack fork	1	A17	Bracket	4
A8	Weight stack rod	1	A18	Ground fixing bracket	1
A9-1	Anchor bracket of shroud (square hole)	2	A19	U bracket	1
A9-2	Anchor bracket of shroud (tapped hole)	2	A33	Top cover	1
A41	Weight plate sticker (10kg~60kg/22lb ~132lb)	1	A34	Anchor bracket	2
A42	Weight plate sticker (65kg~100kg/143lb~220lb)	1			

Box B - User Frame Components					
No.	Name	Qty.	No.	Name	Qty.
A20	CAM	1	A27	Connector A	1
A21	Handle	1	A28	Connector B	1
A23	Seat back	1	A29	Connector C	1
A24	Seat frame	1	A30	Ø50 Connecting board	5
A25	Seat bottom	1	A31	Ø50 Connecting board A	1
A26	Cylindrical cushion arm	1	A32	Finger Guard	

Box C + Box D - Weight Plates Components					
No.	Name	Qty.	No.	Name	Qty.
A40	5kg/11lb weight plate	15			

Components in the Hardware Kit				
No.	Name	Qty.	Specification	Notes
12	Screw soft cap	1		
13	Phillips screw	6	M6*P1.0*L12	
14	Screw socket	1 batch	SGN- 07	
15	Mushroom top inner hex screw	12	M6*P1.0*L12	
16	Mushroom top Phillips screw	8	M5*L15	
17	Mushroom top Phillips screw	10	M5* 0. 8* L8	
18	Round sticker	1	D25	
21	Phillips pan head sheet metal screw	6	M4*L12	
22	Phillips Umbrella head sheet metal screws	2	M4*L14	
23	Round screw cap	2		
50	Flat washer	2	D27*d6.3*t3.0	
	Mushroom top inner hex screw	2	M5*L20	
	Open end wrench	2	(13*17)	
	Phillips-head screwdriver	1		
59	Fastener	1 batch		
	Cap nut	1 batch		
	L-shaped Allen wrench		M6*L120mm*W28	
	L-shaped Allen wrench		M4*L60mm	
	L-shaped Allen wrench		M5*L114mm*W24	

Components on the Product			
No.	Name	Specification	Notes
21	Hex head screw	M10*P1.5*L130	
	Spring washer	M10	
	Washer	D16*d10.2*t1.0	
	Nylon hex lock nut	M10	
22	Upper stack carriage set		
23	Hex bolt	M8*P1.25*L65	
	Washer	D17*d8.3*t2	
	PU tube	ØD12*d8*L51	
	Nylon hex lock nut	M8	
24	Guide rod		
25	Round head inner hex screw	M8*P1.25*L18	
	Spring washer	M8*t2.0	
	Washer	D17*d8*t1.5	
26	Round head inner hex screw	M8*P1.25*L20	
27	Axle cover	Ø65	

Components on the Product			
No.	Name	Specification	Notes
28	Mushroom top inner hex screw	M6*P1.0*L20	
29	Mushroom top inner hex screw	M6*P1.0*L12	
	Spring washer	M6	
	Flat washer	D20*d6.3*t1.5	
30	CAM stop plate		
31	Mushroom top inner hex screw	M6*P1.0*L10	
32	Cable set block		
33	Mushroom top inner hex screw	M6*P1.0*L20	
	Spring washer	M6	
	Nylon hex lock nut	M6	
34	Round head inner hex screw	M8*P1.25*L20	
35	Mushroom top inner hex screw	M8*P1.25*L25	
	Spring washer	M8	
	Flat washer	D17*d8.3*t2	
	Nylon hex lock nut	M8	
38	Mushroom top inner hex screw	M8*P1.25*L25	
	Spring washer	M8	
	Washer	D22*d8.2*t2	
39	Seat back plate		
40	Bevelled head inner hex screw	M8*P1.25*L12	
	Flat washer	D17*d8.3*t2	
41	Mushroom top inner hex screw	M6*P1.0*L12	
43	Mushroom top Phillips screw	M5* 0.8* L15	
	Flat washer	D13*d6*t1.0	
45	Mushroom top inner hex screw	M6*P1.0*L20	
	Flat washer	D16*d6.3*t2	
	Nylon hex lock nut	M6	
46	Reinforcement plate		
	Anchor bracket		
	Umbrella hex screw	M6*P1.0*L20	
	Plastic cover		
47	Umbrella hex screw	M6*P1.0*L12	

4. ASSEMBLE THE PRODUCT

Follow instructions below to assemble this product. Note that in this manual the words “left” and “right” are used to refer to the product and its parts. As such, these designations correspond to the “left” and “right” sides of a person in position to exercise on this product. Also, for brevity, the word “screws” or “nuts” is used where washers and other hardware may be involved.

STEP 1 Cover Support Plate and Connector Installation

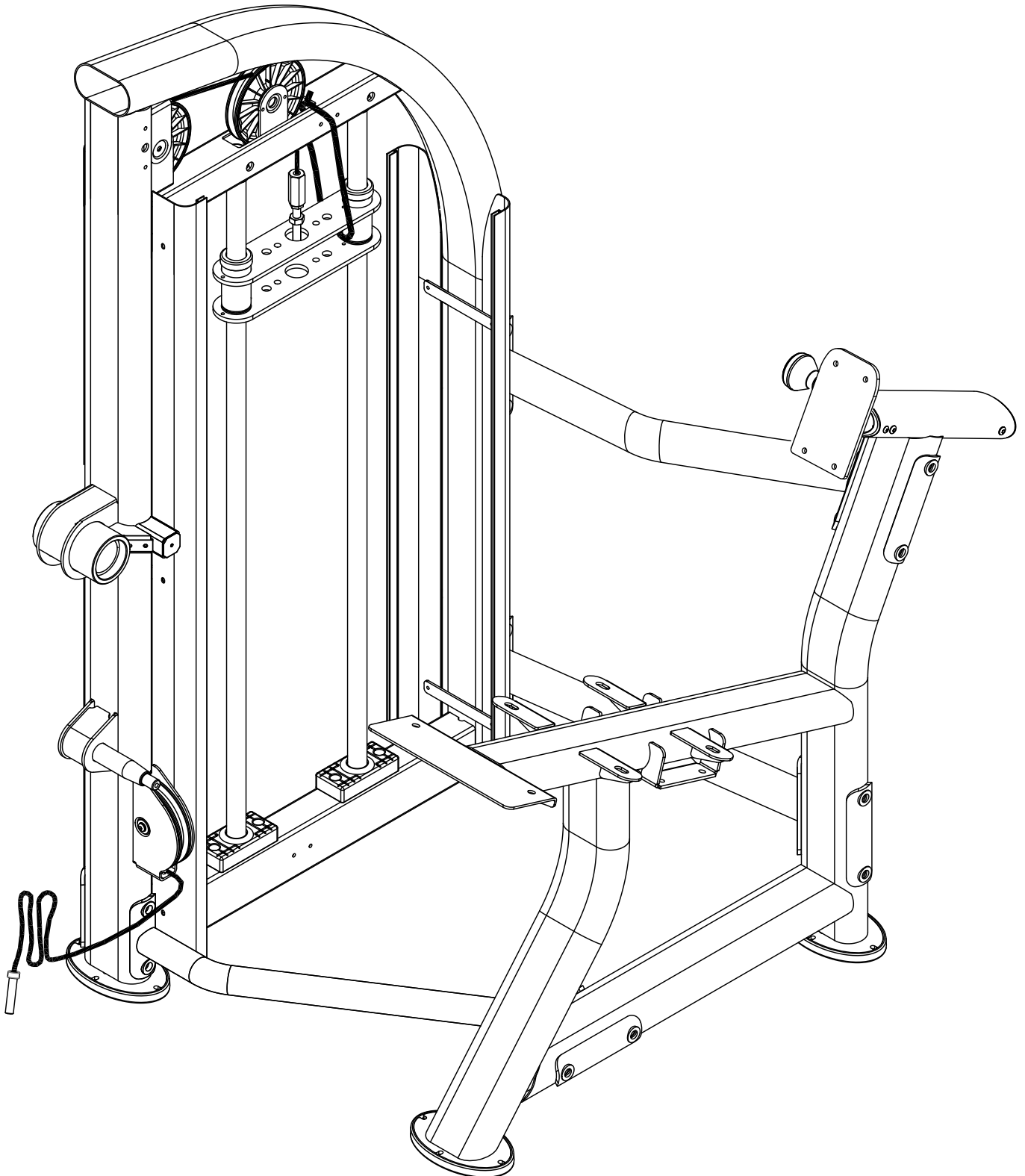

STEP 1 Cover Support Plate and Connector Installation (CONT.)

(a). Insert the screw sockets (14) into place in the main frame (A3) as shown, and then use the screws (15) (16) to secure the brackets (A16) (A17) in place.

(Note: The bracket (A16) must be secured to the top of main frame as shown.)

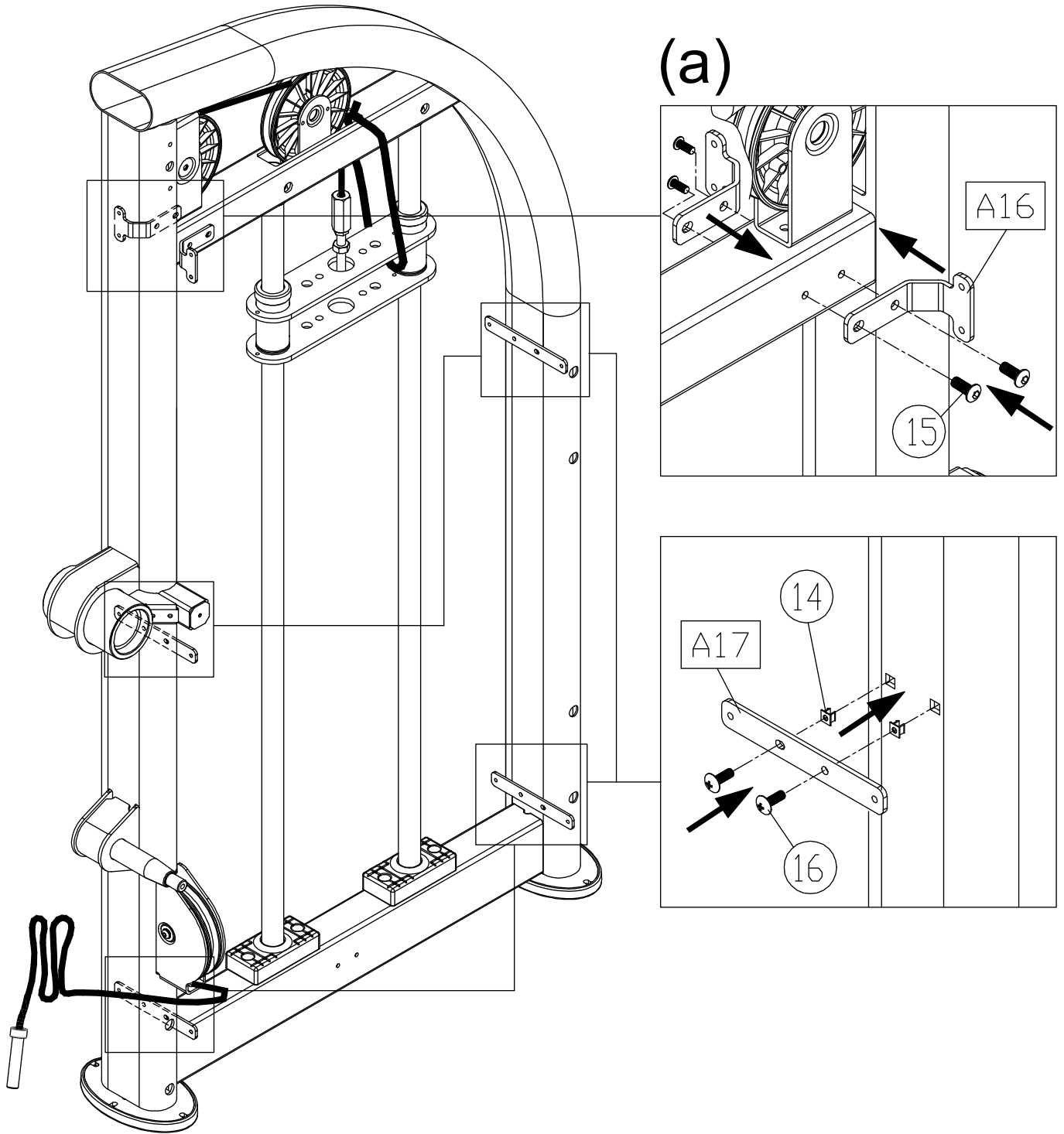

STEP 1 Cover Support Plate and Connector Installation (CONT.)

(b). Use the screws (17) to secure the cover support plates (A10) to the straight frame of the main frame (A3) and then secure the cover support plates (A4) (A5) to the both side of the curved frame as shown.

(Note: The cover support plates must be secured outside of the bracket (A16) (A17).)

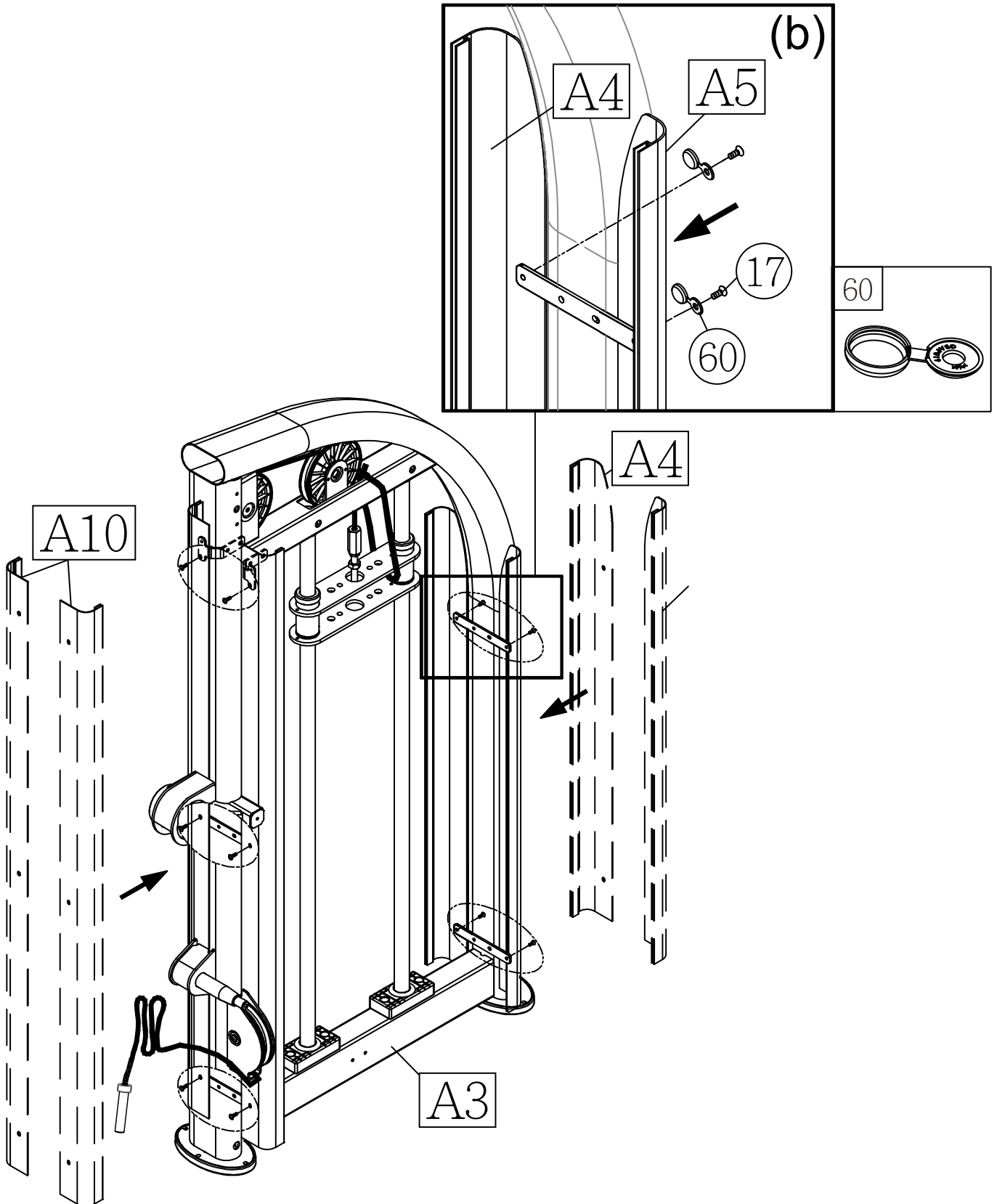

STEP 1 Cover Support Plate and Connector Installation (CONT.)

(c). Use the screws (21) to secure the connecting board A (A31) to the connector C (A29) and the main frame (A3) in area A. Use the screws (21) to secure the connecting board (A30) to the connector C (A29) and the seat frame (A24) in area B. And then use the screws (21) to secure the connecting board (A30) to the connector A (A27), the connector B (A28), the main frame (A3) and the seat frame (A24) as shown.

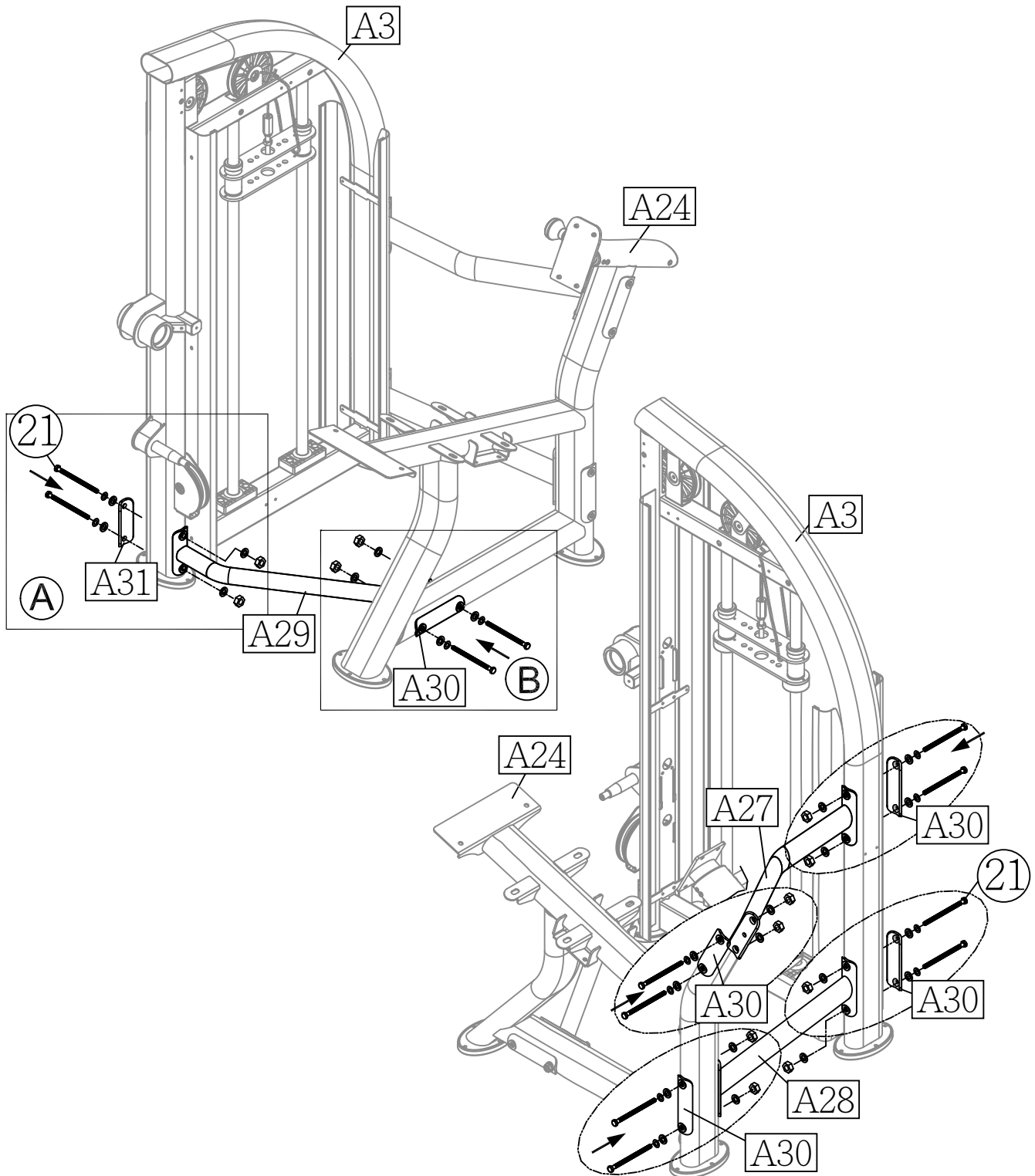

STEP 2 Weight Stack Installation

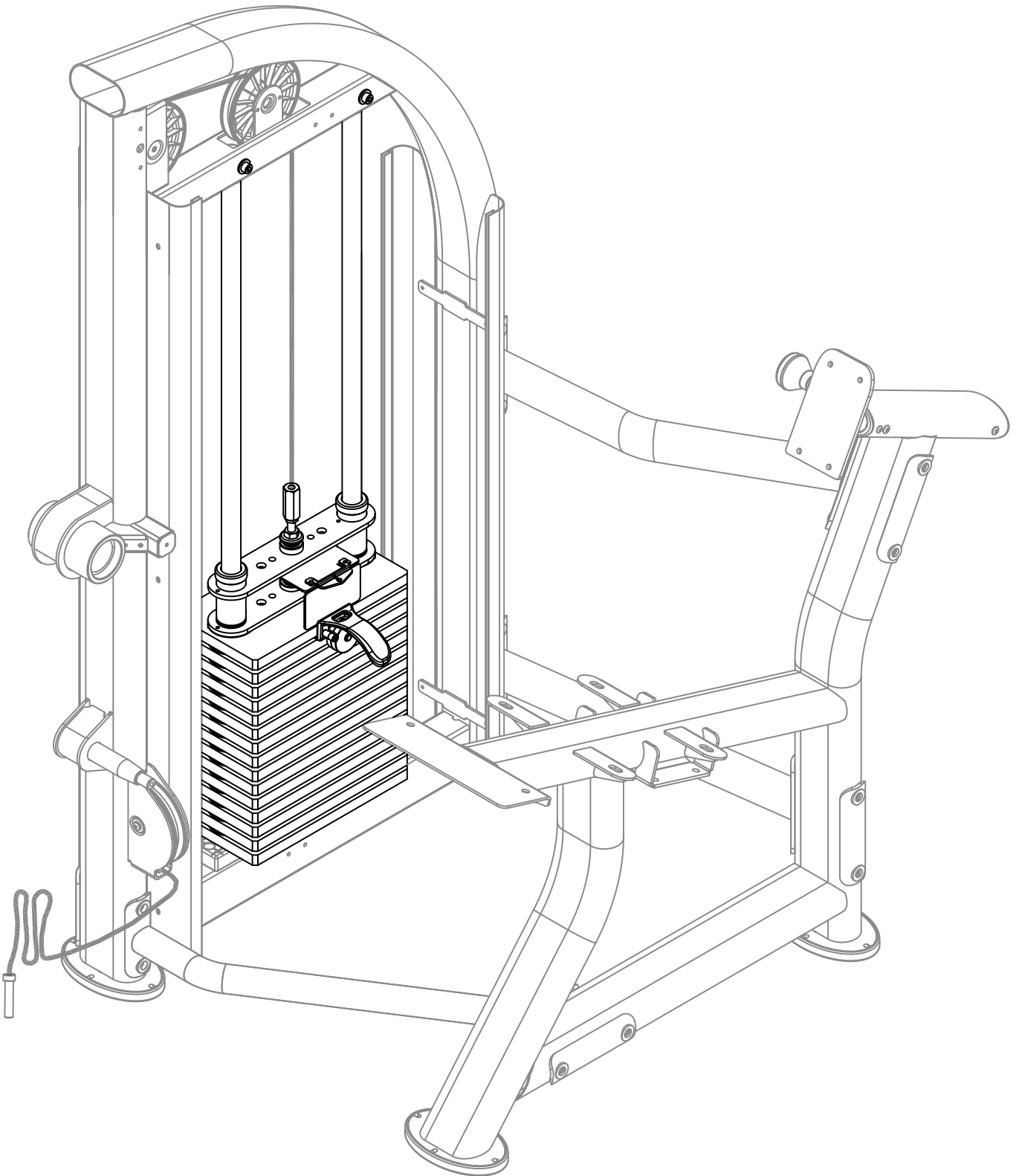

STEP 2 Weight Stack Installation (CONT.)

- (a) Hold the upper stack carriage set (22), and then cut the zip tie. Gently lower the upper stack carriage set (22) into place as shown.
- (b) Remove the screws (23). Set the guide rod (24) downward into place as shown.
- (c) Tilt the guide rod (24) backward and then lift the upper stack carriage set (22) off the guide rods as shown. Carefully set the upper stack carriage set (22) aside.

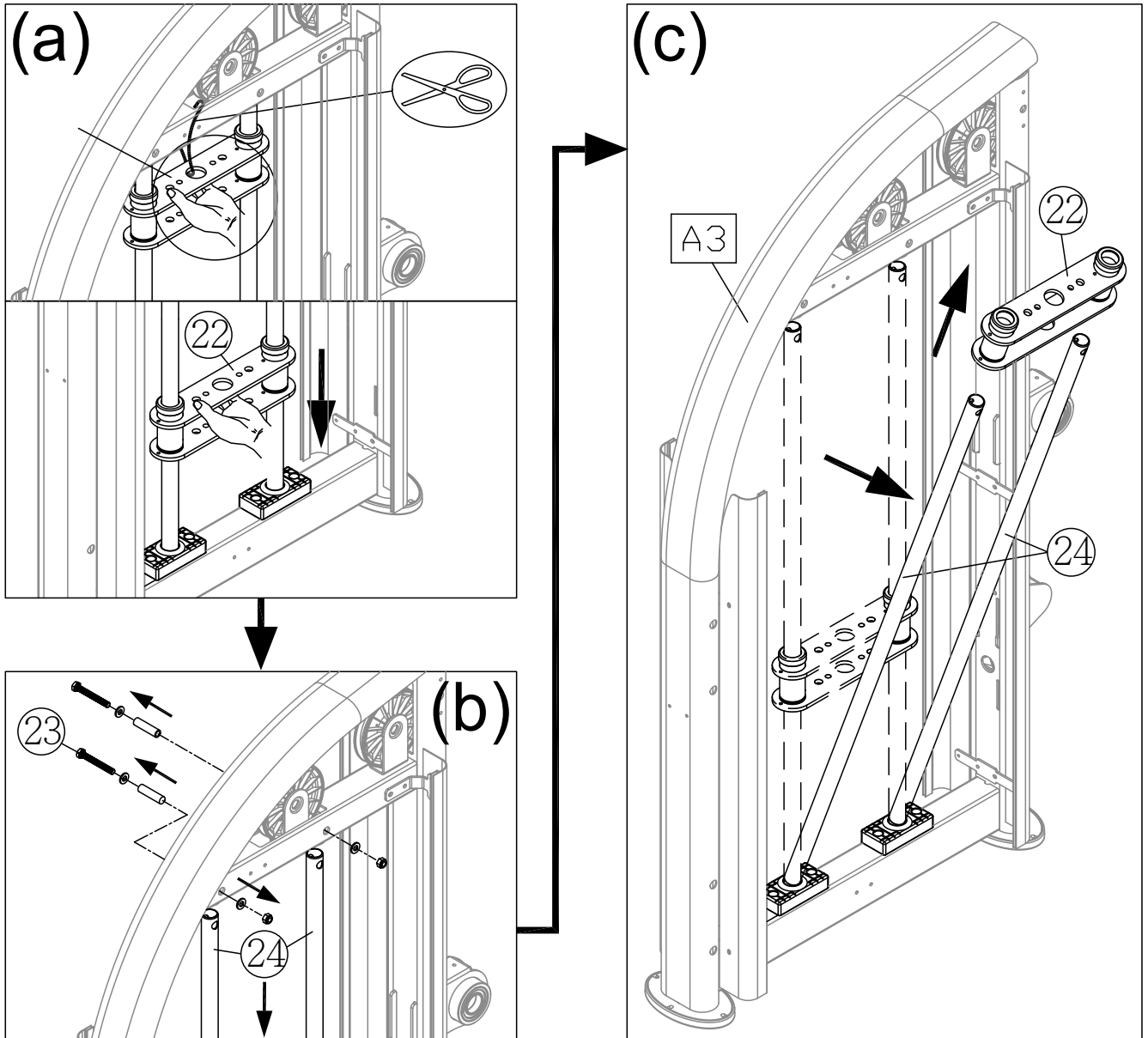

STEP 2 Weight Stack Installation (CONT.)

- (d) Loosen and remove the screws (25) from the stack fork (A7) and insert the weight stack rod (A8) into the central mounting position of the upper stack carriage set (22). Use the screws (25) to secure the stack fork (A7) into place of the upper stack carriage set (22) as shown. *(Note: Remove the stack fork first before assembling.)*
- (e) Insert and lower the (5 kg/11lb) weight plates (A40) into place on the guide rods (24) one at a time. Once complete, slide down the upper stack carriage set (22) on top of the weight stack. *(Note: The stack fork (A7) points toward the front.)*
- * If there is an optional (7.5kg/16.5lb) weight plate installed, insert the optional weight plates first before the (5 kg/11lb) weight plates (A40).
(Note: The convex side of weight plate should face up.)
- * Install the cap nuts on the screws.

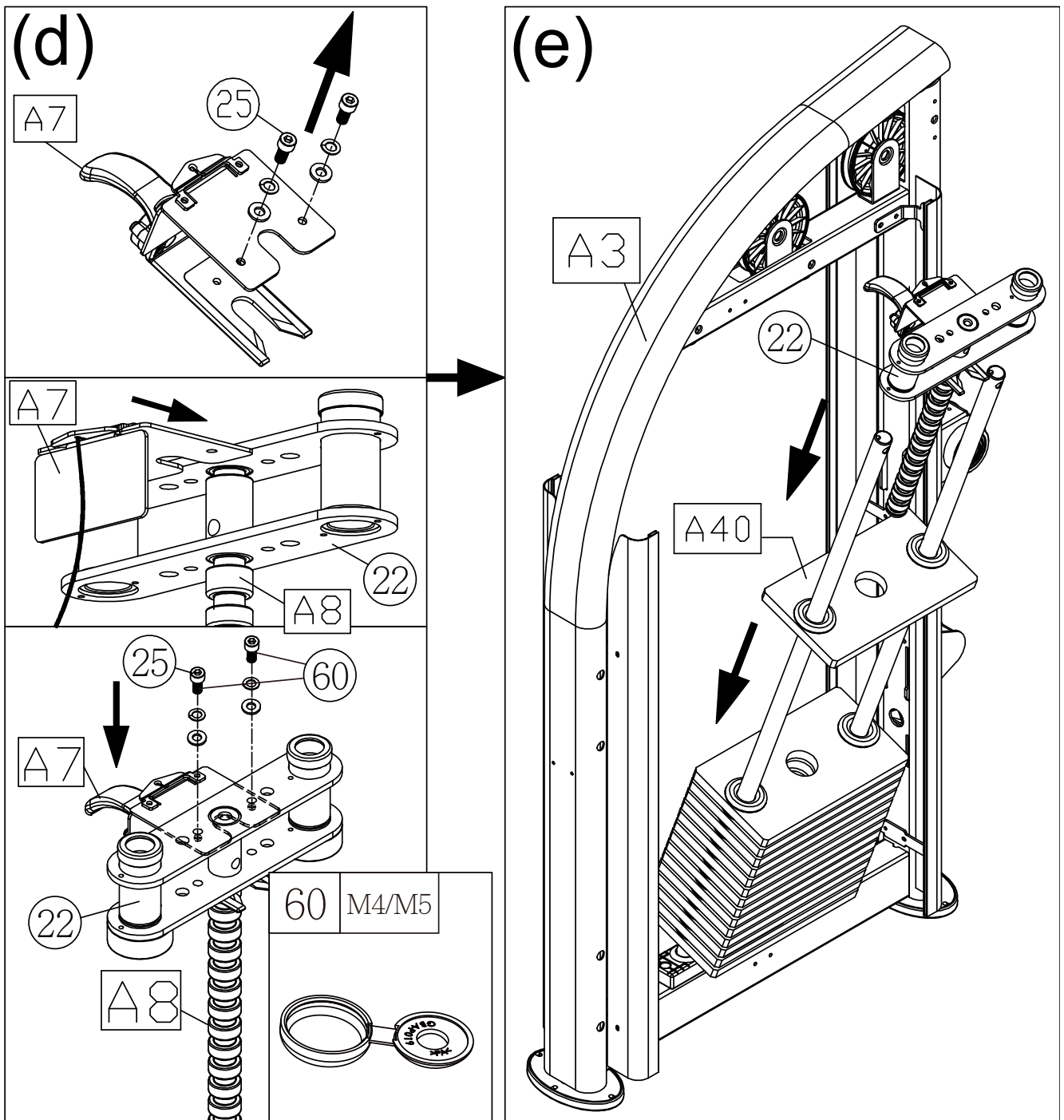

STEP 2 Weight Stack Installation (CONT.)

(f) Tilt the guide rods (24) back into place and then lift them up to their mounting position, and then secure the assembly with screws (23).

*Install the cap nuts on the screws.

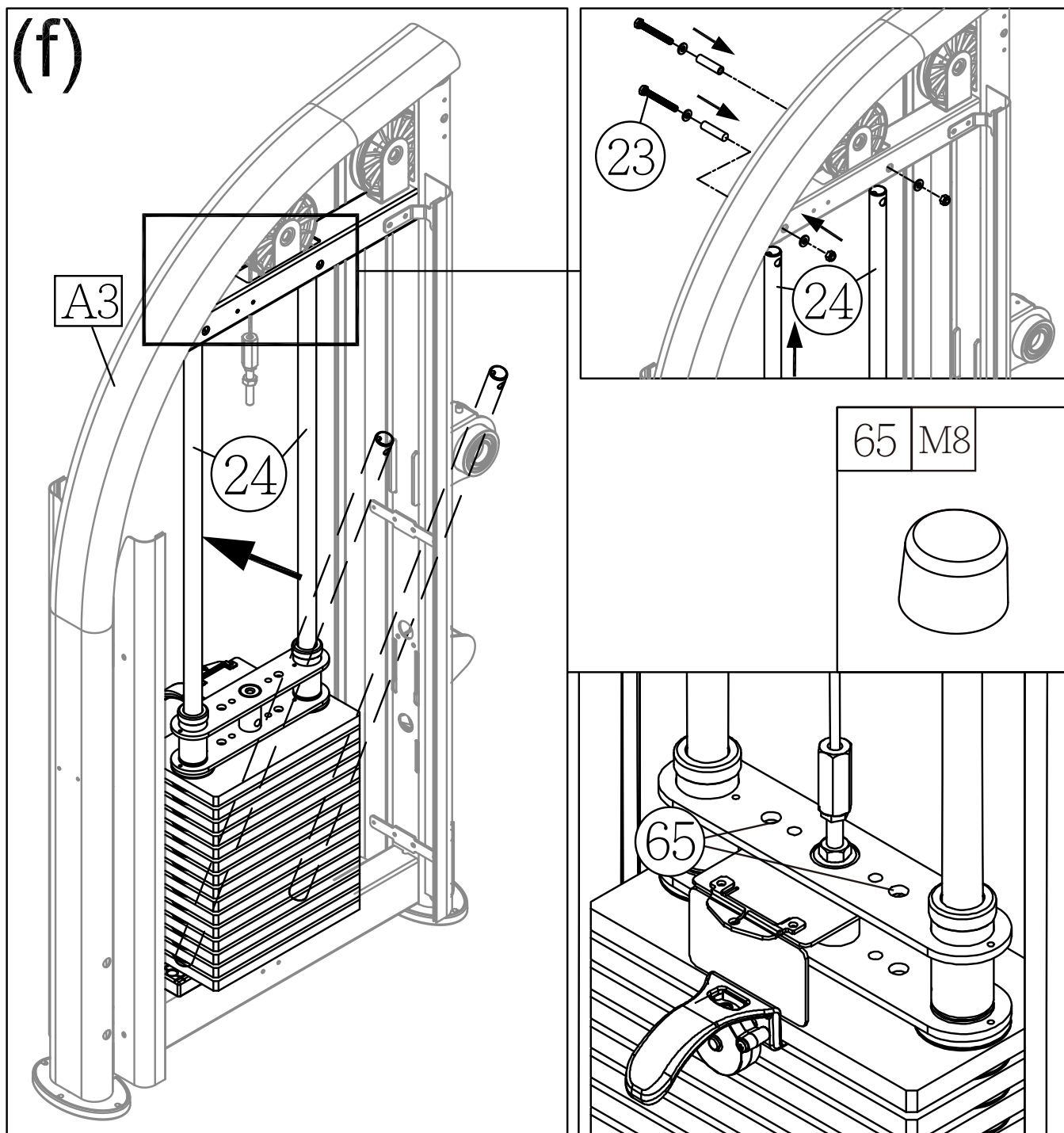

STEP 3 CAM Installation

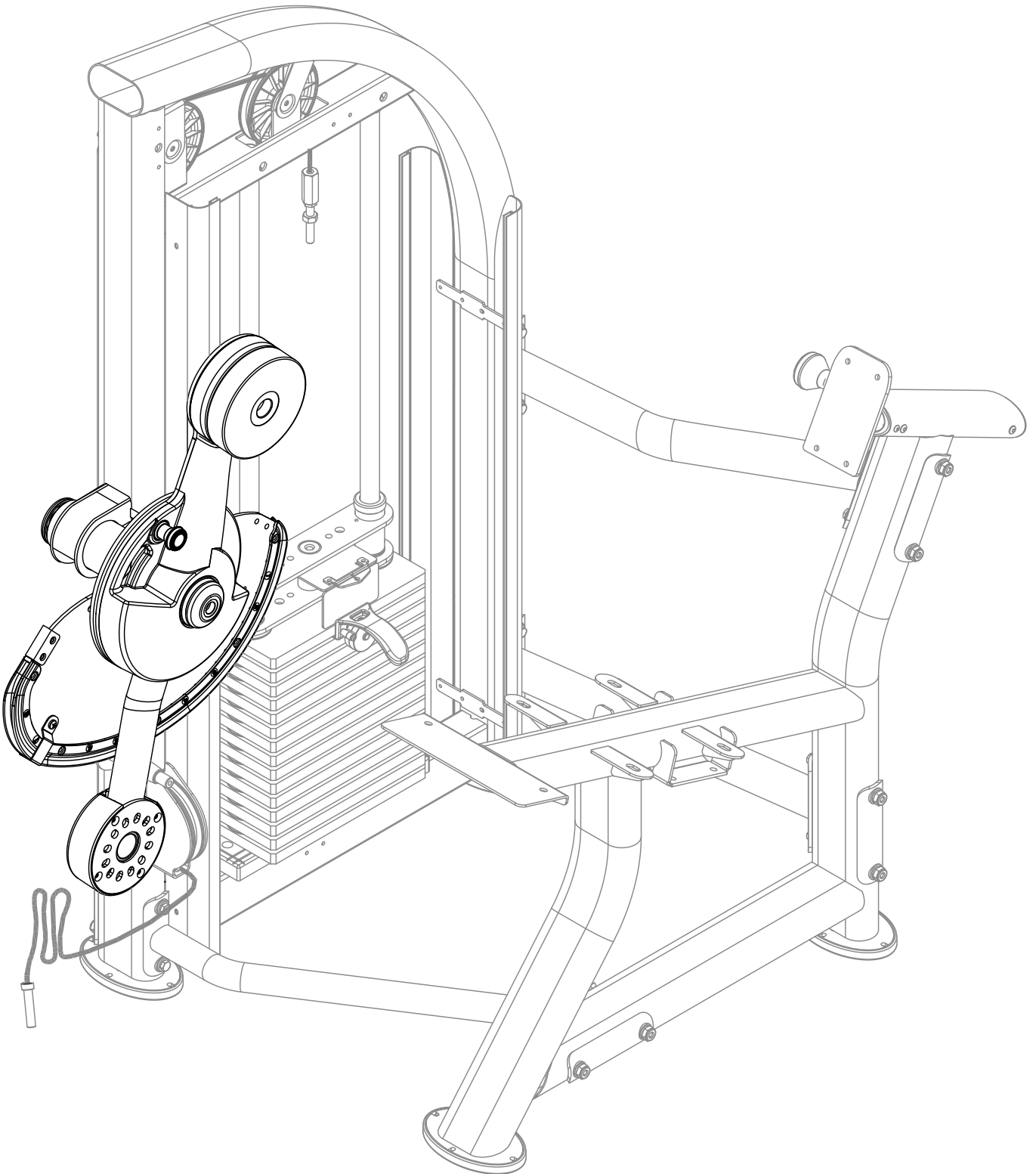

STEP 3 CAM Installation (CONT.)

- (a) Loosen and remove screw (26) and the cap (27) from the CAM (A20).
- (b) Place the CAM (A20) horizontally into its mounting area, and then rotate the cam so that the rotator arm is pointing downward as shown.
(Note: Due to the CAM hasn't been connected to the cable yet, to avoid any injuries, please make sure no one is near the CAM.)
- (c) Secure the axle cover (27) in place with screws (26), and then apply the round sticker (18) as shown.
(Note: The stopper must be rested below the tube as shown.)

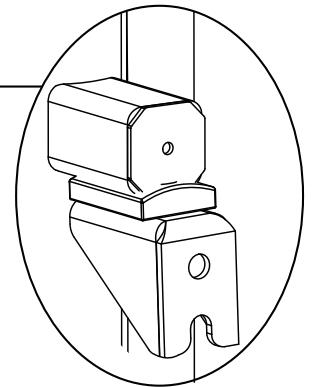
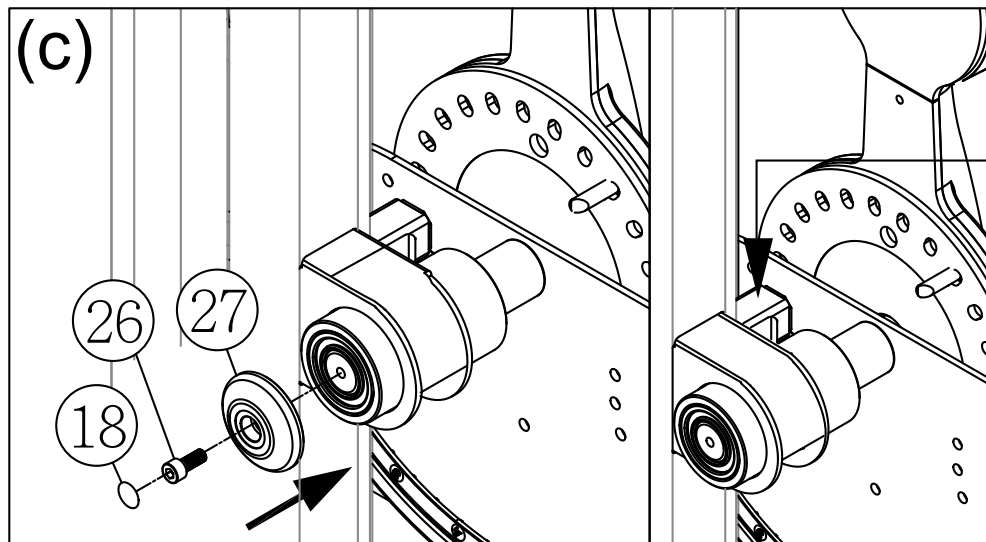
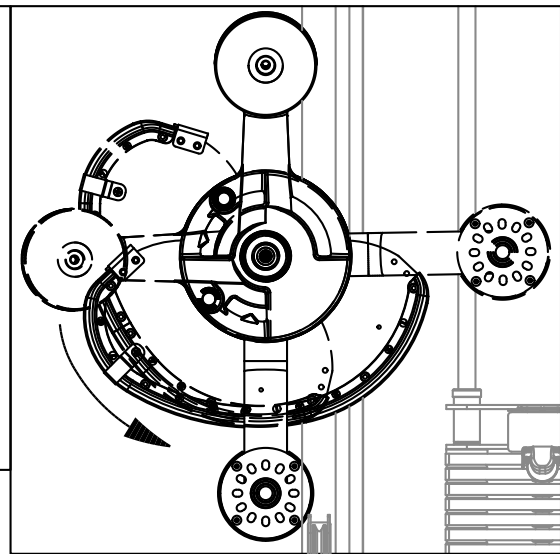
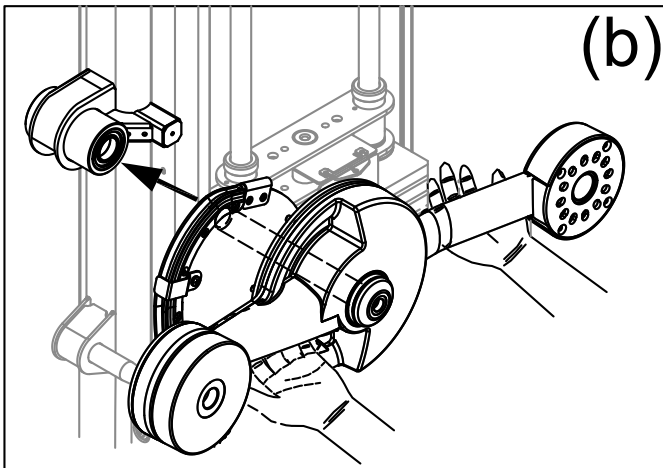
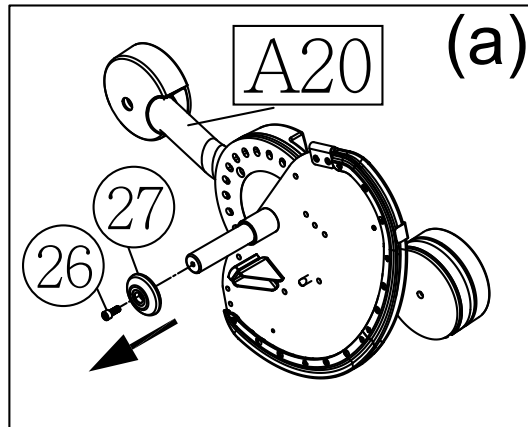

STEP 4 Cable Installation

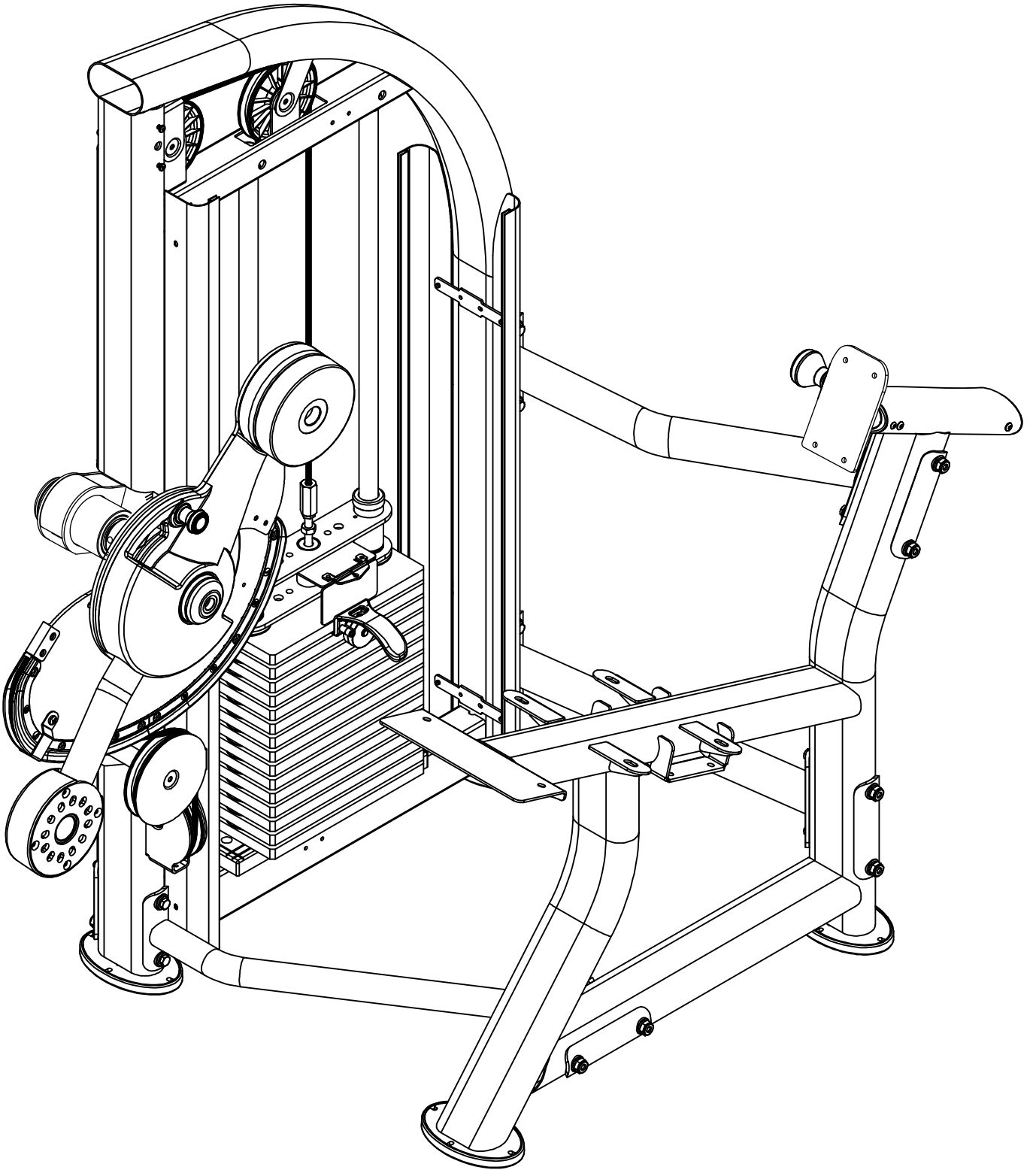

STEP 4 Cable Installation (CONT.)

- (a) Insert the cable nut as indicated by the arrows onto the weight stack rod (A8) at least 15-20mm deep as shown.
- (b) Take out the stack fork (A7) and lift the upper stack carriage set (20) up.
- (c) Insert the stack fork (A7) into the stack rod (A8) so that the cable is loose. This will make the next assembly easier.

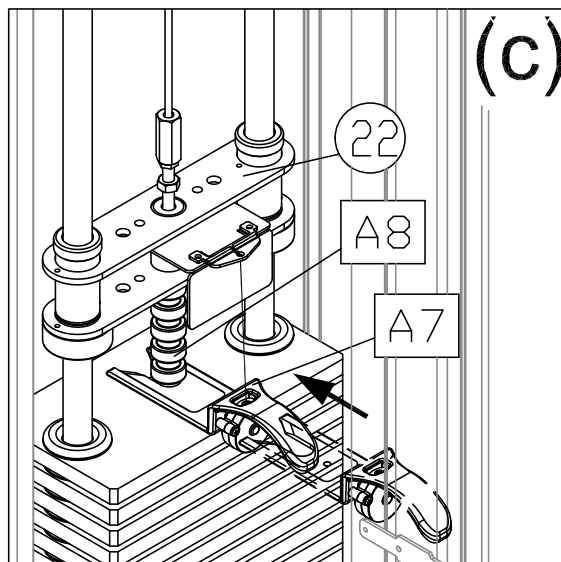
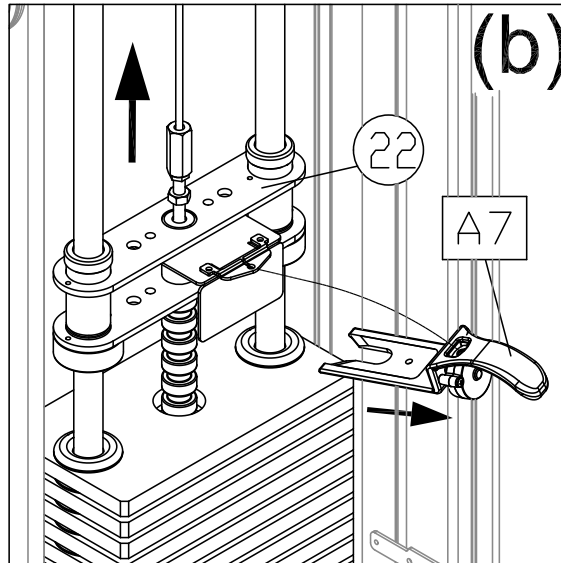
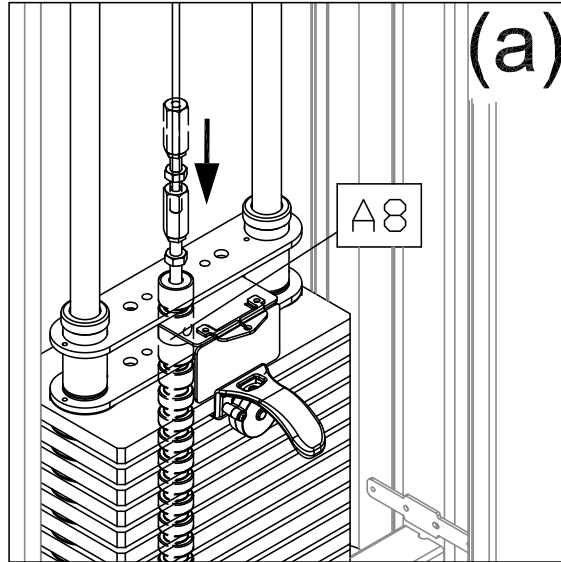

STEP 4 Cable Installation (CONT.)

- (a) Loosen and remove screws (29) (31) (33), the cable set block (32) and the CAM support plate (30) from the main frame.
- (b) Install the pulley (A13) and insert the cable goes through the pulley (A13) as indicated by the arrows, and then secure the pulley cover (A12) in place with screws (29).
(Note: When securing the pulley cover, make sure the cover does not interfere with cable.)
- (c) Insert the cable through the cable set block (32) as indicated by the arrows, and then secure the cable set block (32) and the CAM support plate (30) in place with screws.
(Note: When securing the cable set block (32), make sure the cable nut is at outside and the CAM stop plate (30) does not interfere with cable when securing it back into place.)

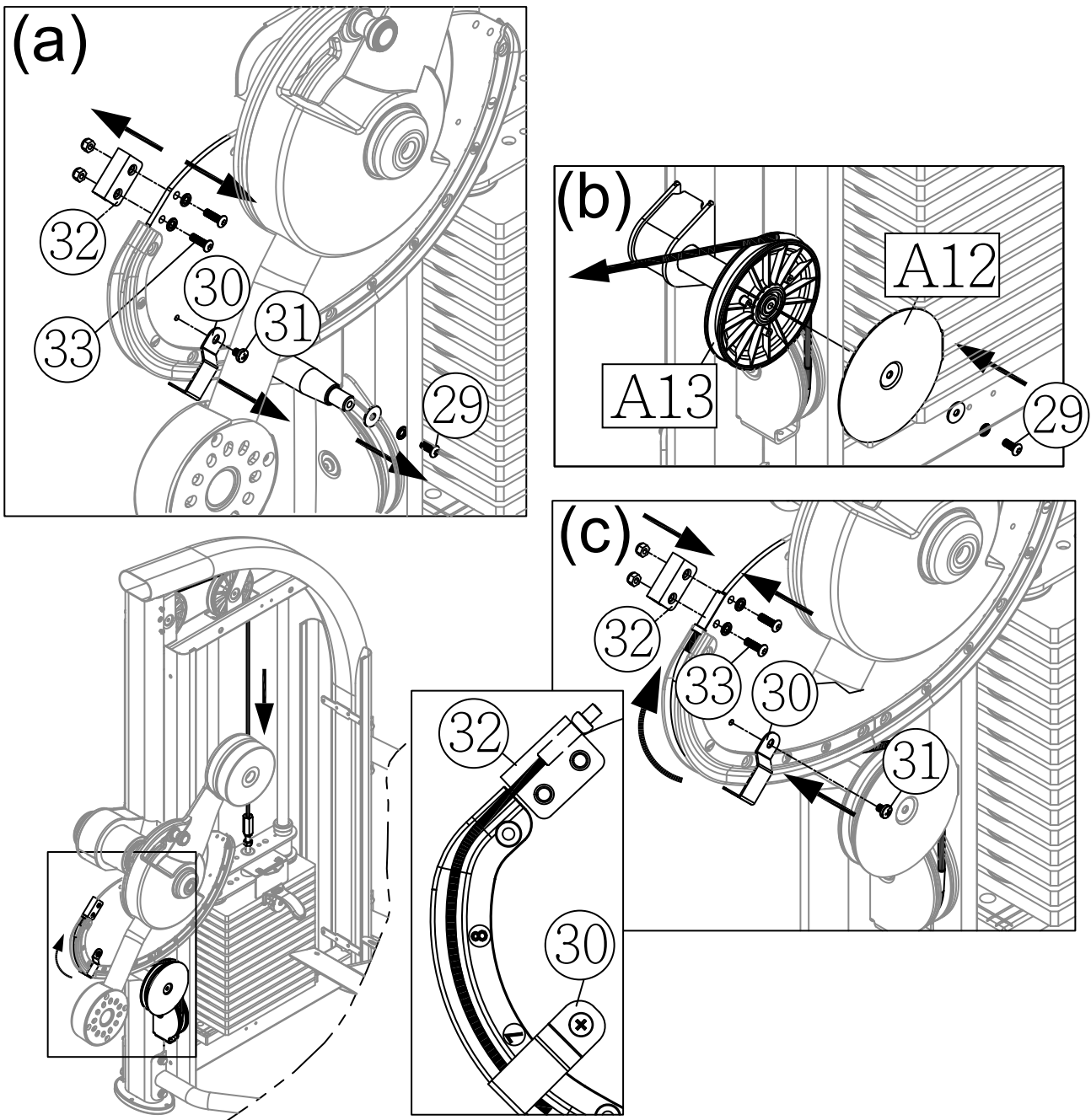

STEP 4 Cable Installation (CONT.)

- (d) After completing the cable installation, hold the upper stack carriage set (22), and then take out the stack fork (A7). Gently lower the upper stack carriage set (22).
(Note: Please make sure that the cable is running in the groove of the pulley. Rotate the CAM to check for cable interference and its tightness. If the cable is too loose or too tight, follow the cable adjusting instruction to adjust it.)
- (e) Remove screws (45) from the CAM (A20).
- (f) Secure the finger guard (A32) with screws (45).as shown.

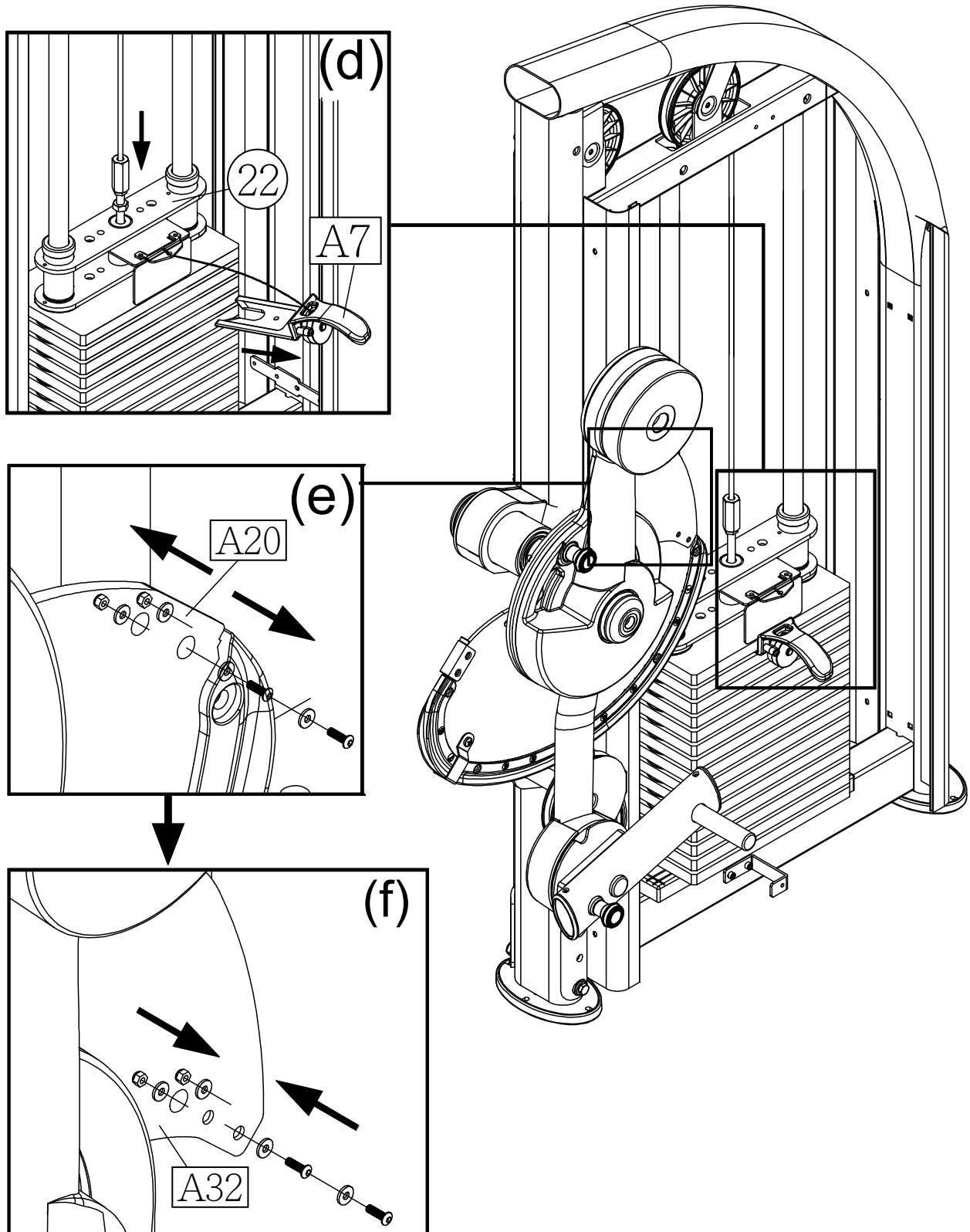

STEP 5 Handle Installation

- (a). Loosen and remove the screws (35) from the handle (A21).
- (b). Rest the handle (A21) beneath the seat frame (A24) as shown, and then secure the screws (35).

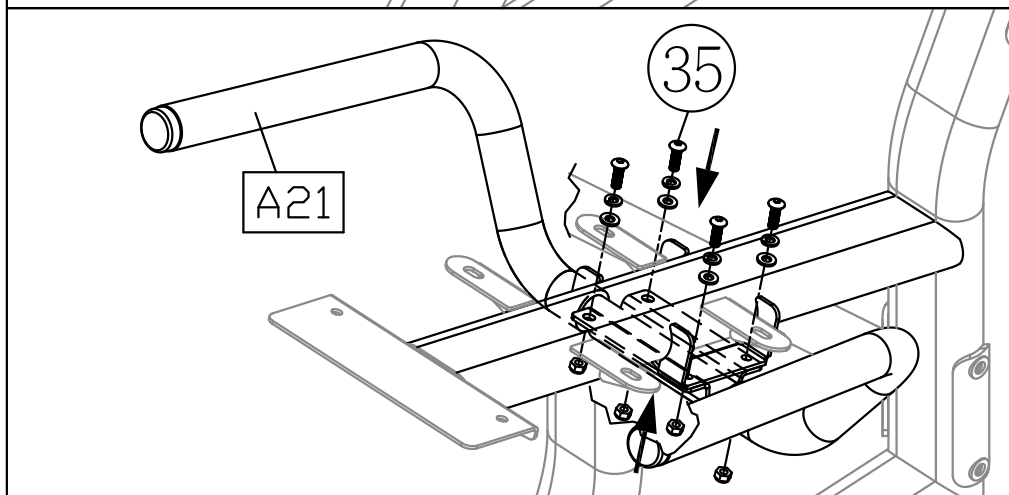
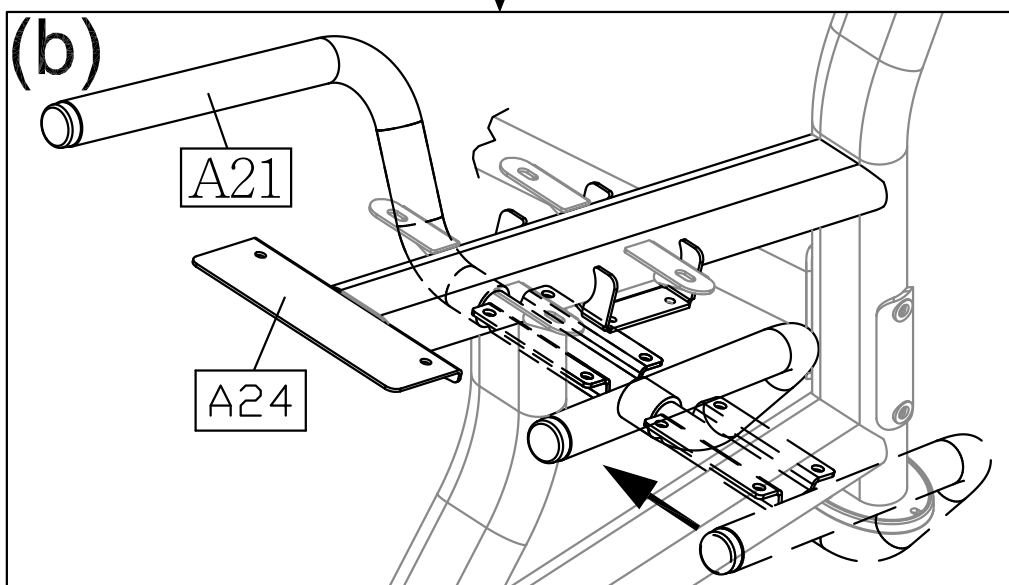
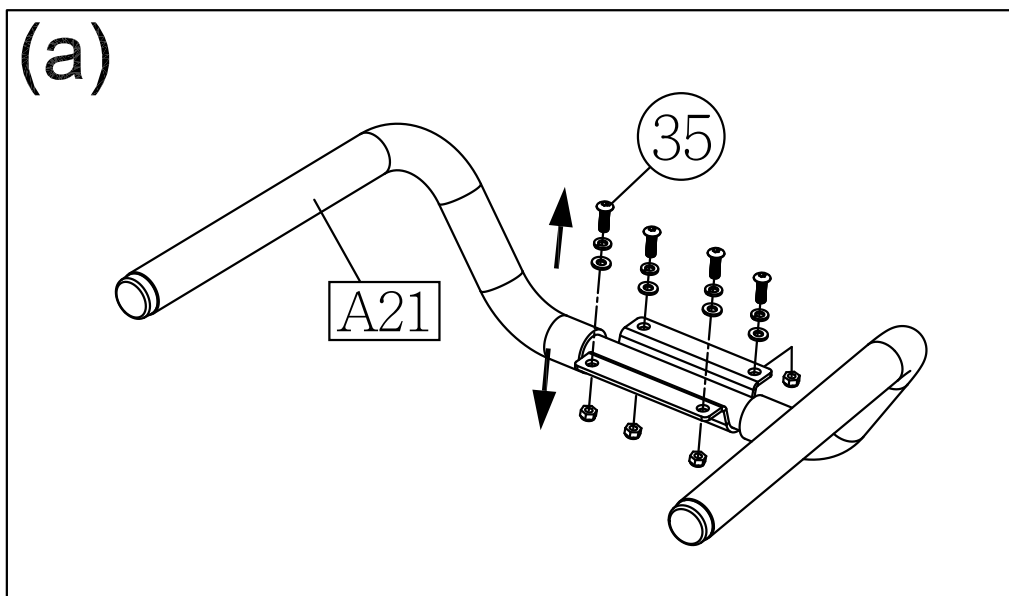

STEP 6 Cylindrical Cushion Arm Installation

- (a). First, remove the screws (34) from the cylindrical cushion arm (A26).
- (b). Insert the cylindrical cushion arm (A26) onto the CAM (A20). Secure it in place with the screw (34) and the screw soft cap (12).

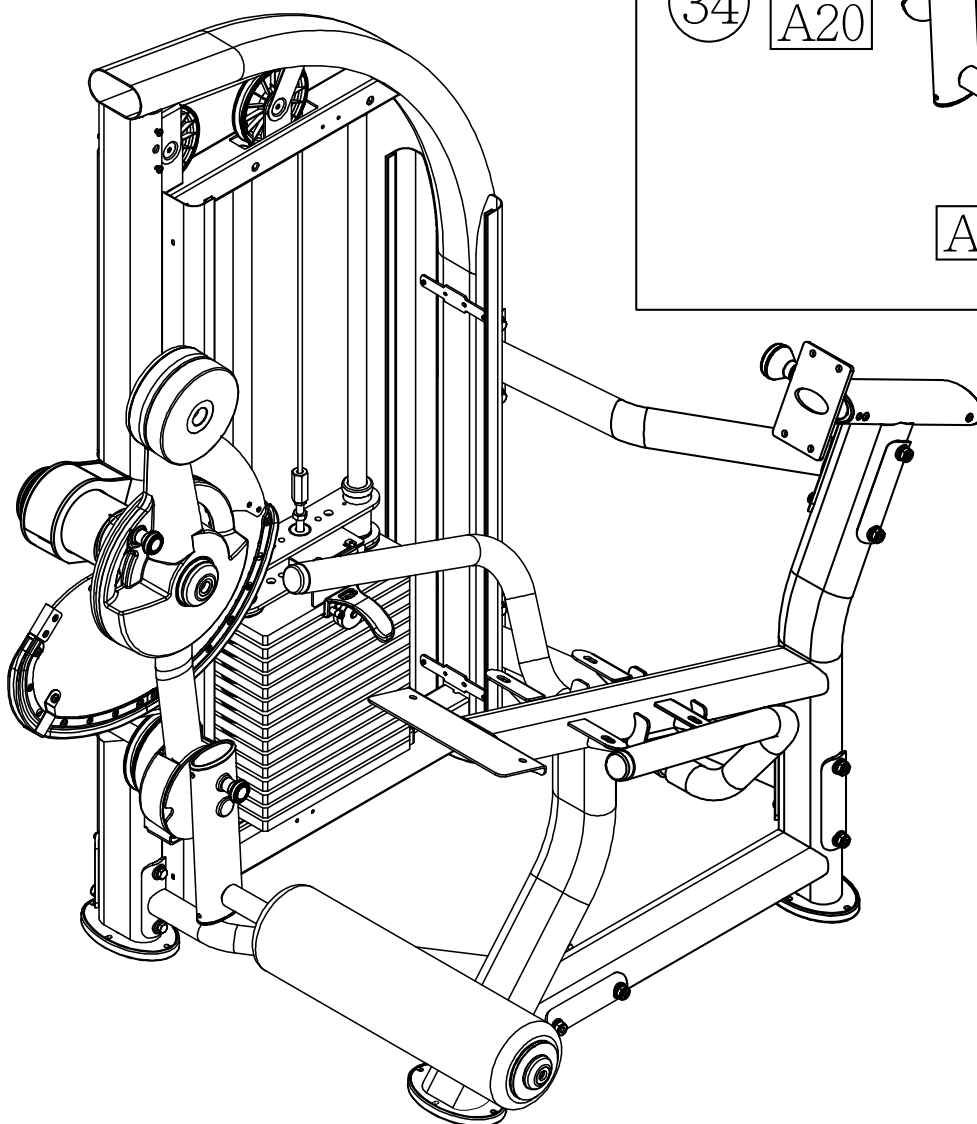
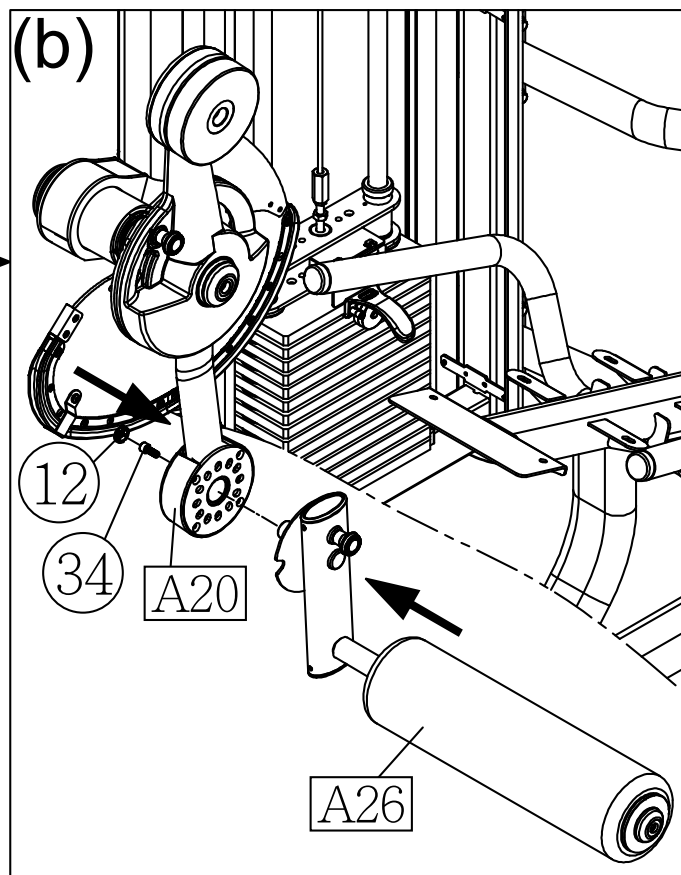
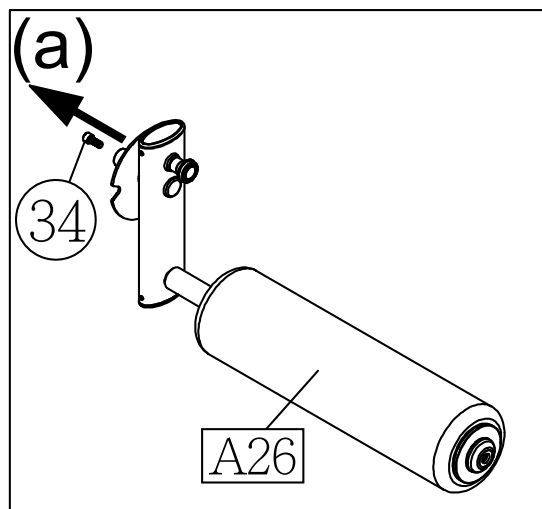

STEP 7 Seat Bottom and Seat Back Installation

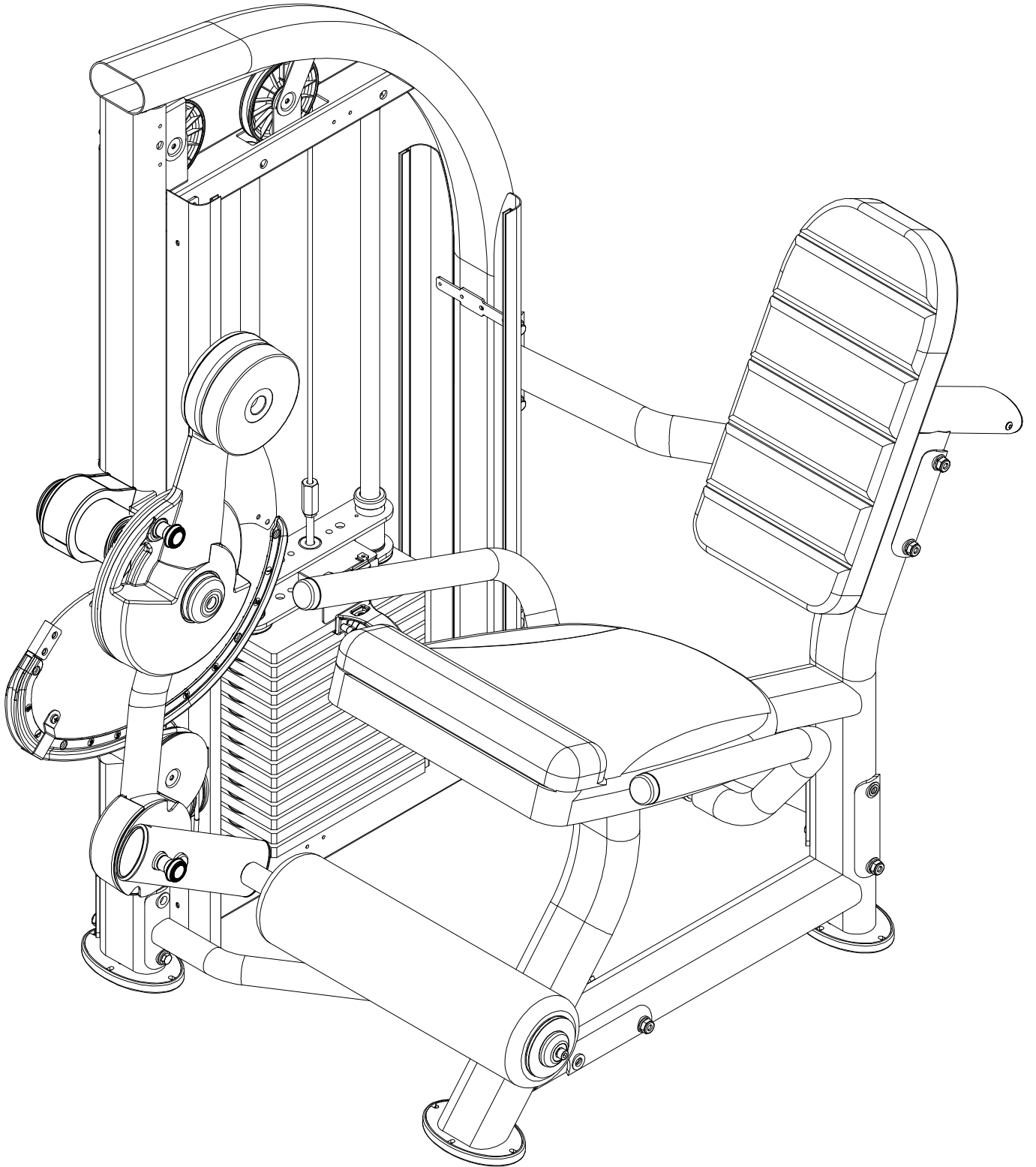

STEP 7 Seat Bottom and Seat Back Installation (CONT.)

- (a) First, remove the screws (38) (40) from the seat bottom (A25), the seat back (A23) and the seat back mount.
- (b) Use the screws (38) to secure the seat bottom (A25) to the seat frame (A24).
- (c) Use the screws (40) to secure the seat back plate (39) to the seat back mount and secure the seat back (A23) to the seat back plate (39) with the screws (38).

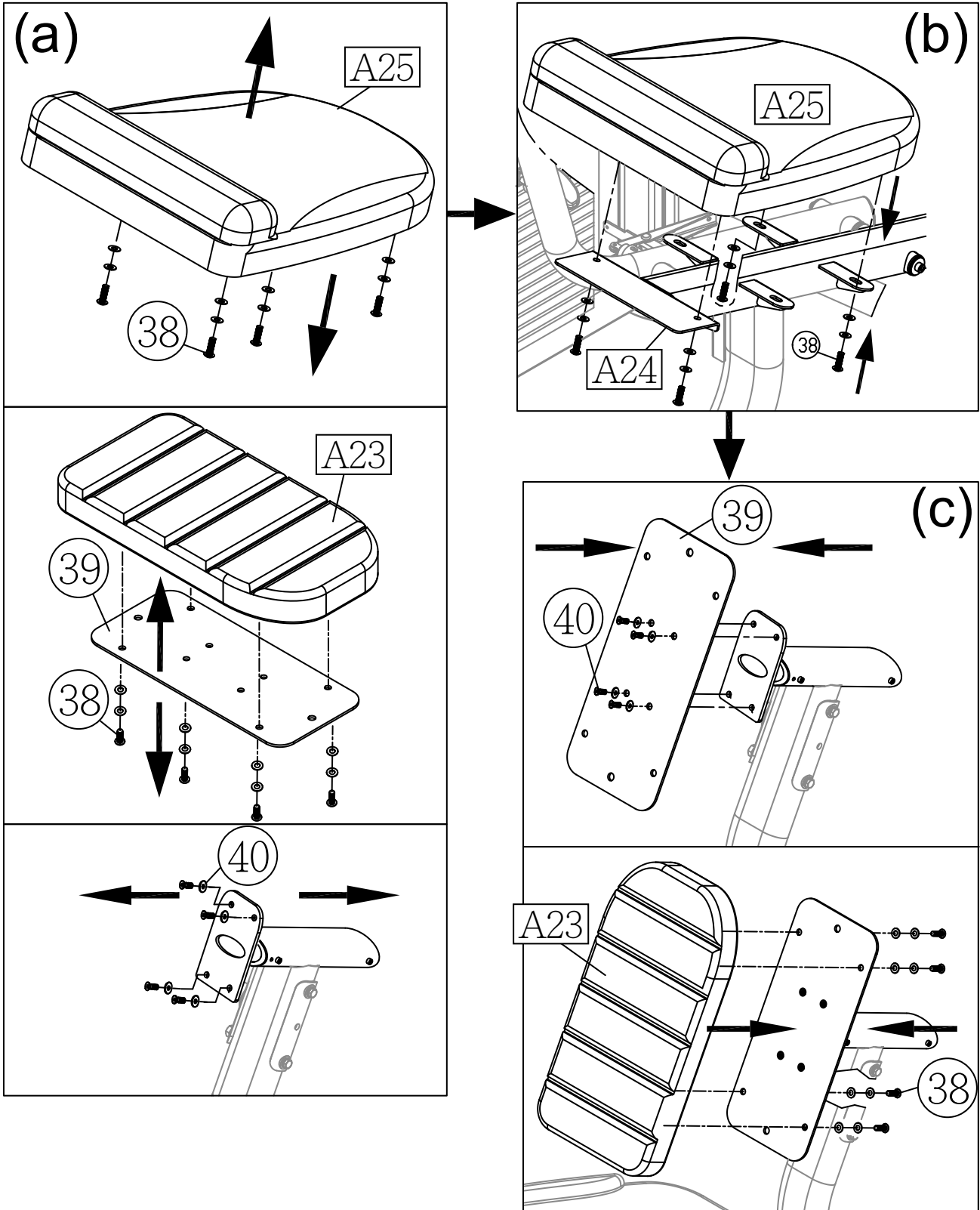

STEP 8 Apply the Weight Stack Sticker

Note: Before applying weight plate stickers, please wipe the area clean, and clean your hands before proceeding to the next step.

- (a) Align and tape the cardboard to the upper left corner of the weight plate (A40).
- (b) Peel off the top half of the weight plate sticker (A41) backing. Leave the clear outside margin in place on the sticker. Don't peel off the margin.
- (c) Press the numbered part of the weight plate sticker (A41) in place while you peel off the clear margin of the sticker.
- (d) Peel off the clear margin of the sticker.
- (e) Follow steps (b) ~ (d) to apply the weight plate sticker (A42) to the lower part of the weight stack. When the stickers are in place, peel off the cardboard. Press the sticker in place to ensure good contact on the weight plate.

*If there are additional optional weight plates, use the optional weight plate stickers.

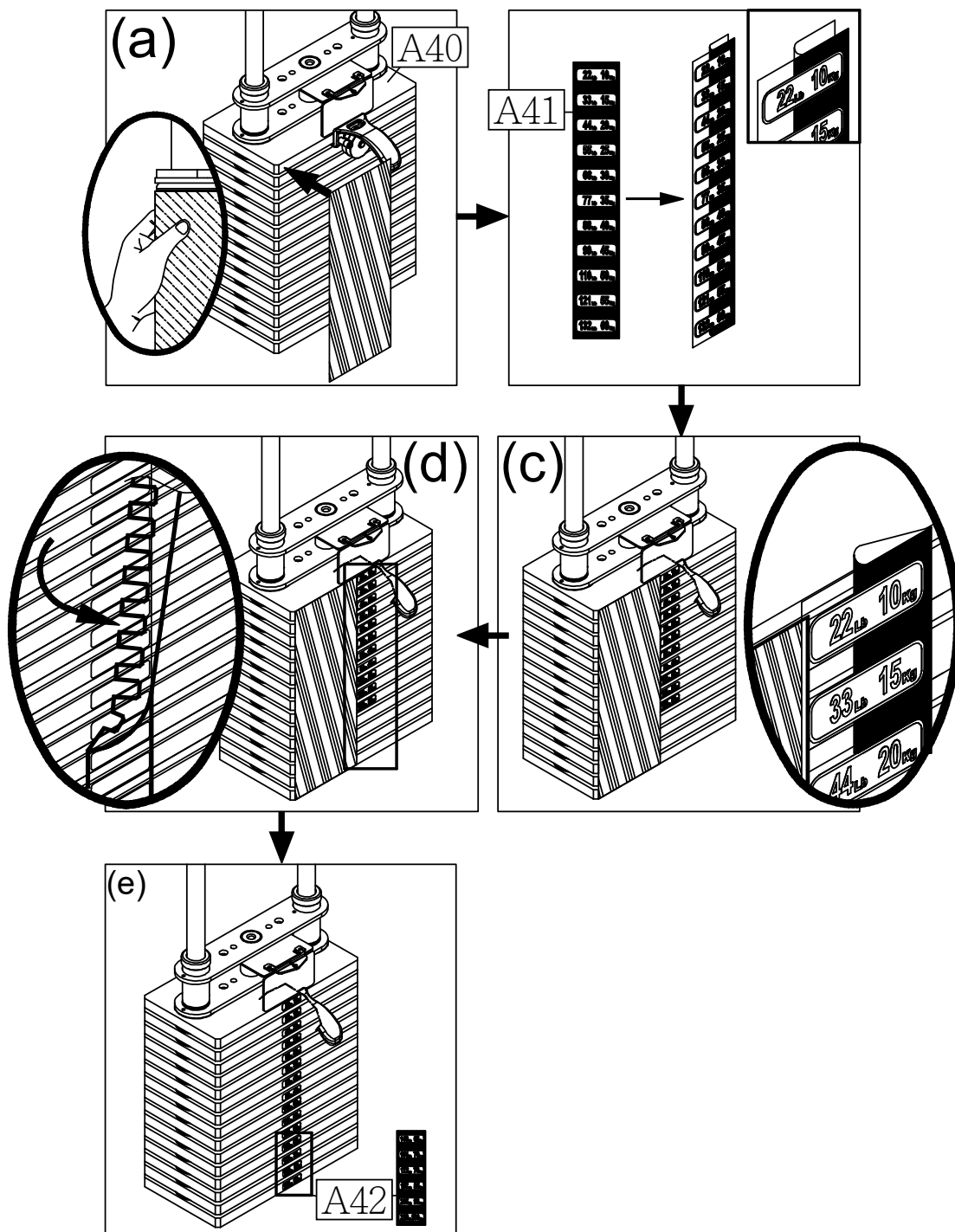

STEP 9 Front Cover and Rear Cover Installation

- (a) Loosen and remove the screws (41) from the main frame.
- (b) Install the square snap bushings (14) to the anchor brackets of shroud (square hole) (A9-1). Secure the anchor brackets of shroud (square hole) (A9-1) with the square snap bushings (14) to the front and back of the upper crossmember assembly of weight stack tower (A3) with screws (41). Secure the anchor brackets of shroud (tapped hole) (A9-2) to the front and back of the lower crossmember assembly of weight stack tower (A3) with screws (41).

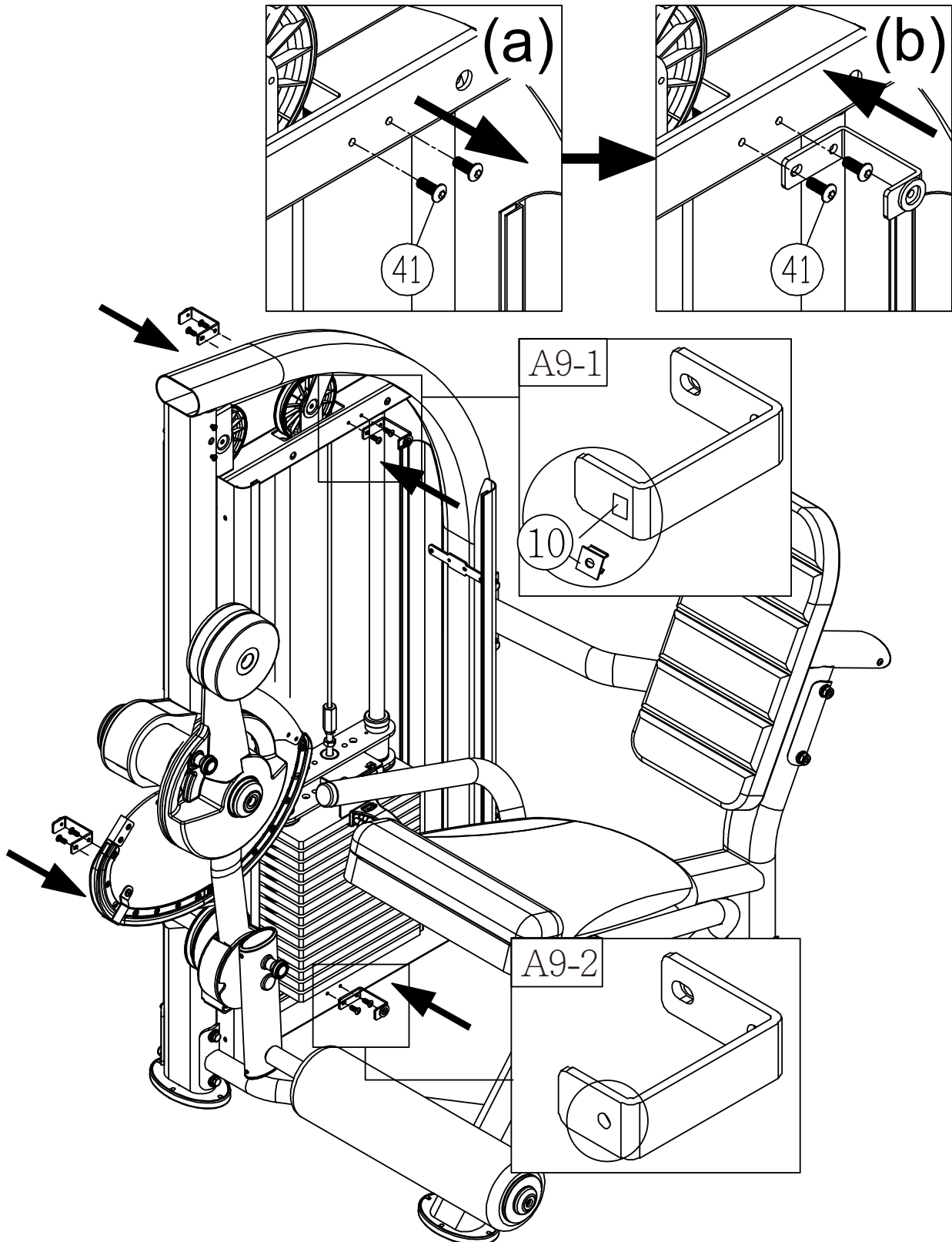

STEP 9 Front Cover and Rear Cover Installation (CONT.)

- (c) Take out the stack fork (A7) and place it on the upper stack carriage set (22) as shown to avoid damaging to the cover.
- (d) Slide the front cover (A15) from the top down into the cover support plates' grooves (A5) (A10).
- (e) Secure the lower shroud with the screw (46).
- (f) Put the stack fork (A7) back in place.

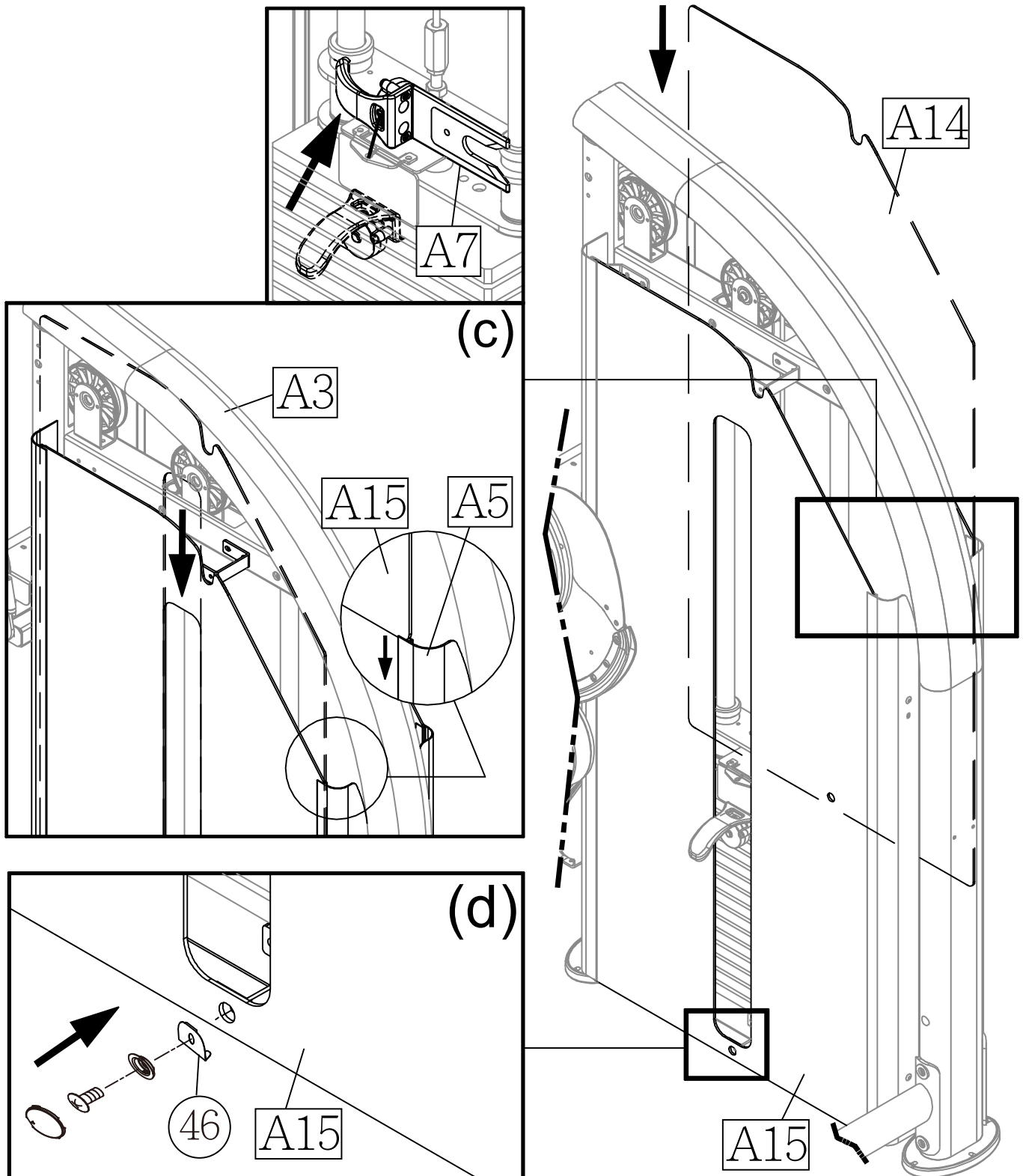

STEP 9 Front Cover and Rear Cover Installation (CONT.)

- (g) Slide the rear cover (A14) from top down into the cover support plates' grooves (A4) (A10).
- (h) Secure the lower shroud with the screw (46).

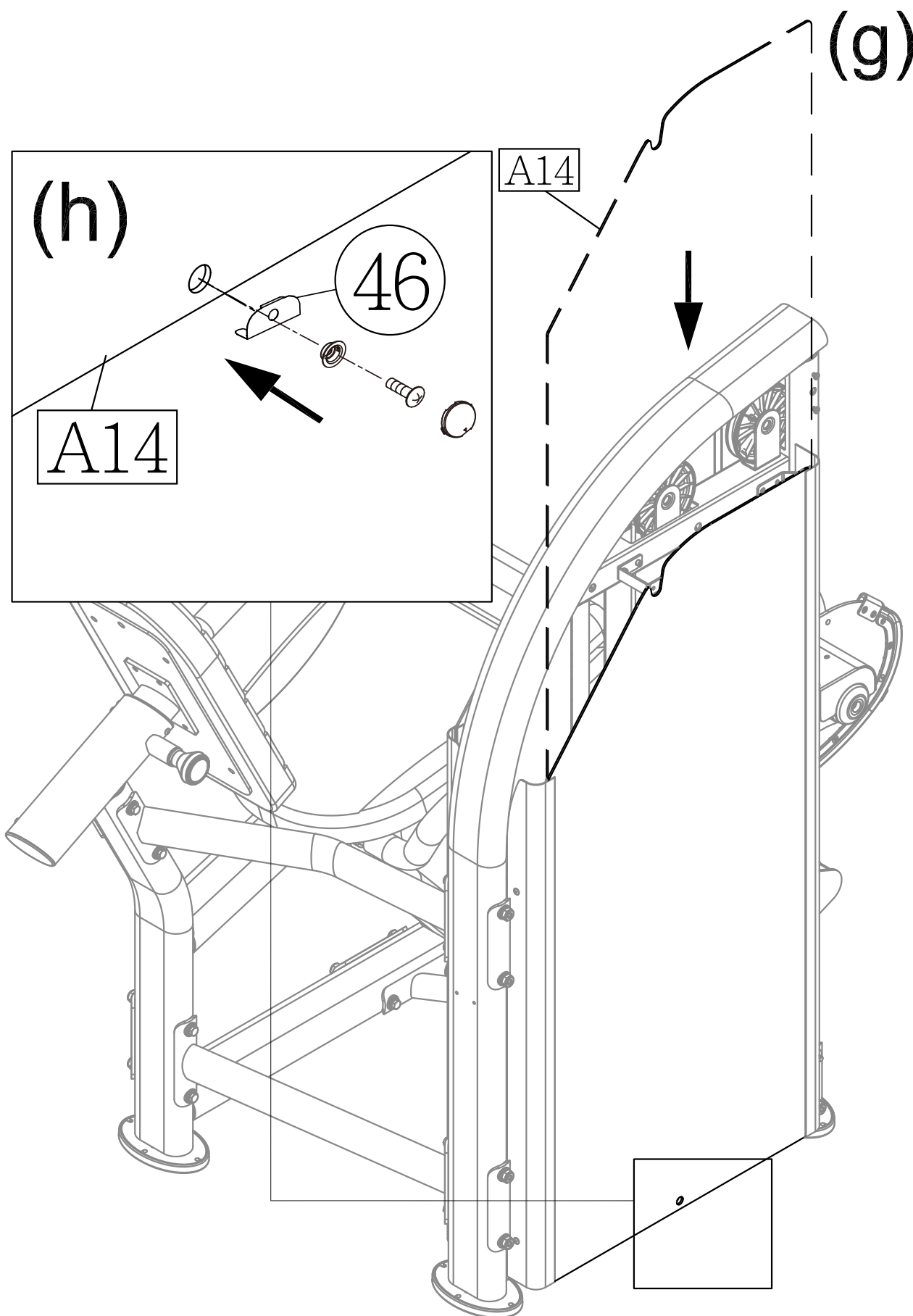

STEP 10 Install plastic cover



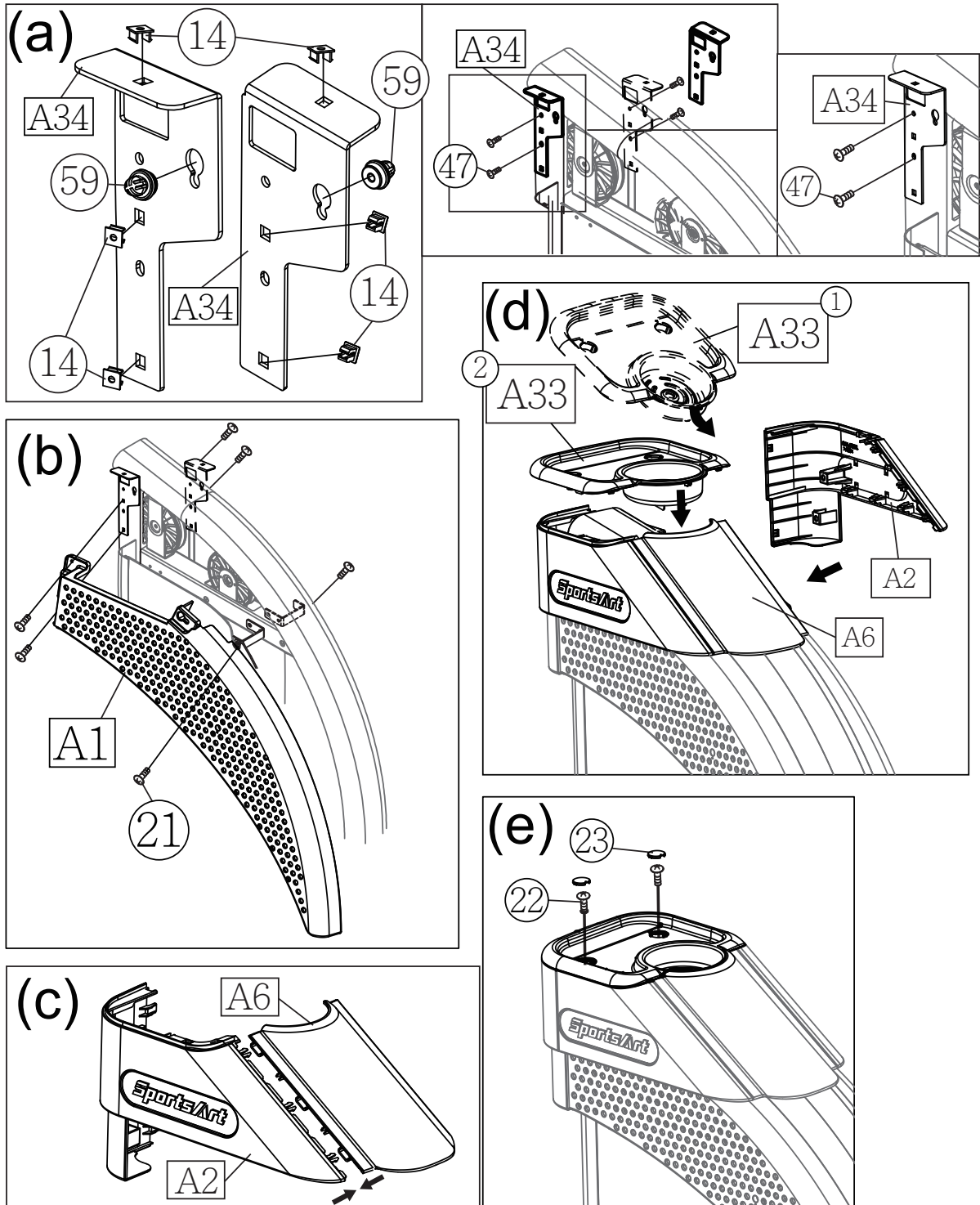

- (a) Install the square snap bushing (14) and fastener (59) to the anchor bracket (A34) and remove the screws (47) on the main frame. Secure the anchor bracket (A34) to the main frame with the screws (47).
- (b) Secure the left/right perforated boards (A1) to the main frame with the screws (21).
- (c) Assemble the right side cover (A2) and the front cover A (A6) together before installing to the main frame.
- (d) Assemble the left side cover (A2) and the front cover A (A6) together and then embed the top cover (A33), which is the water bottle holder, at an oblique angle.
- (e) Secure the top cover (A33) to the main frame with the screws (22) and then install the round screw caps (23).

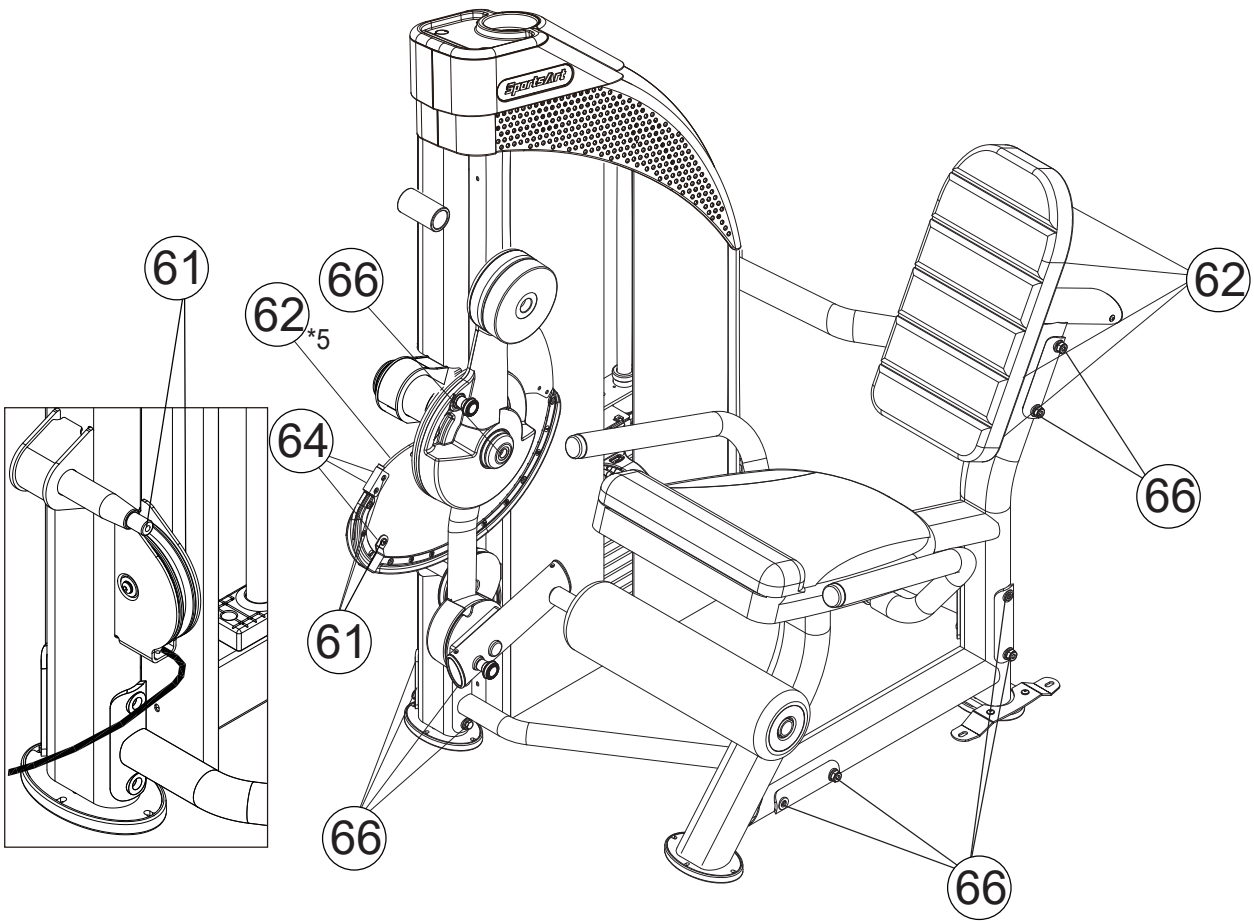

STEP 11 Install cap nut

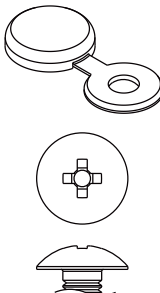
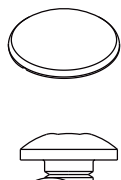
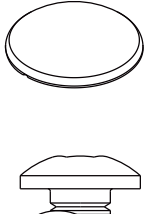
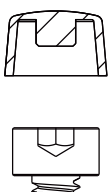
Install the cap nuts to the corresponding positions according to the following numbers.

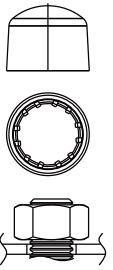

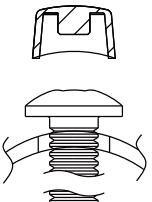
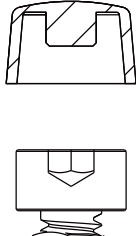
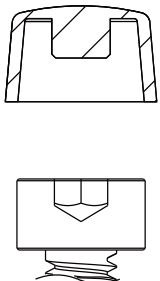
60 GBA-P019	61 GBA-P024	62 GBA-P014	63 GFA-P136	64 GBA-P018
				
65 GBA-P017	66 GBA-P016	67 TAO-P096A	68 GFA-P137	69 GFA-P138
				

STEP 12 Secure the Product

- (a) Remove screws (43) from the ground fixing bracket (A18).
 - (b) Insert the U clip (A19) onto the machine (Make sure the U clip with the correct side downward as below shown), and then secure the ground fixing bracket (A18) with screws (43).
 - (c) Secure the ground fixing bracket on the ground with the ground fixing bolt, nut and washer as shown to make sure the machine is stable on the ground.
- (Note: The screw hole of ground fixing bracket is $\varnothing 9\text{mm}$, please make sure using the suitable ground fixing bolt and drilling the proper hole on the ground.)*

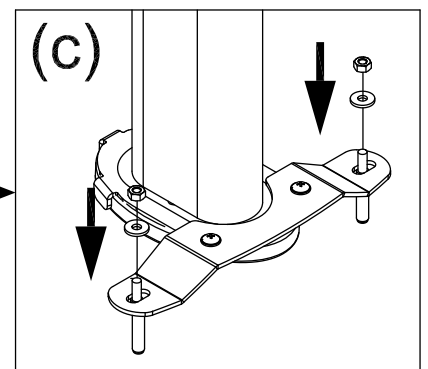
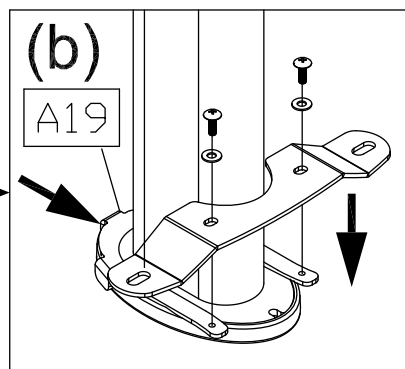
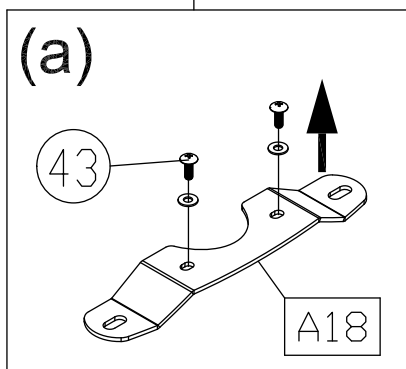
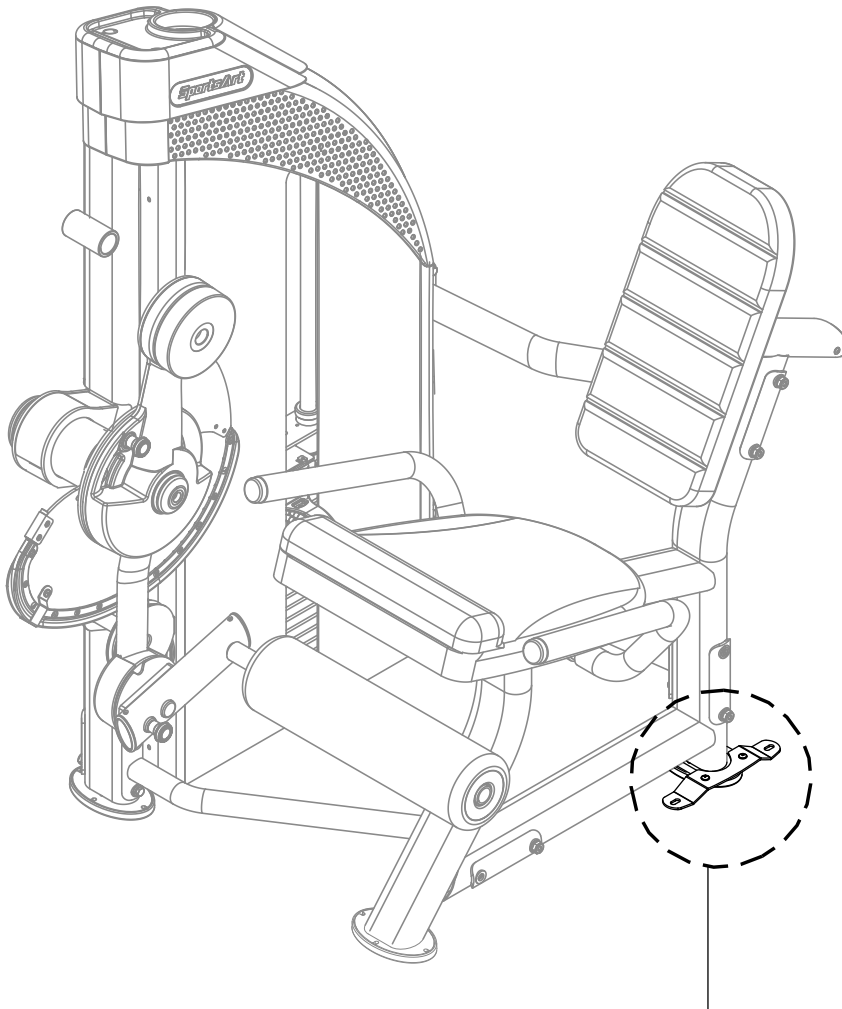

STEP 13 Level the Product

If the product is installed on an uneven surface to cause the instability of the product, place the support spacer under the foot pad to make sure its stability. (A few support spacers are provided in the packaging of this product.)

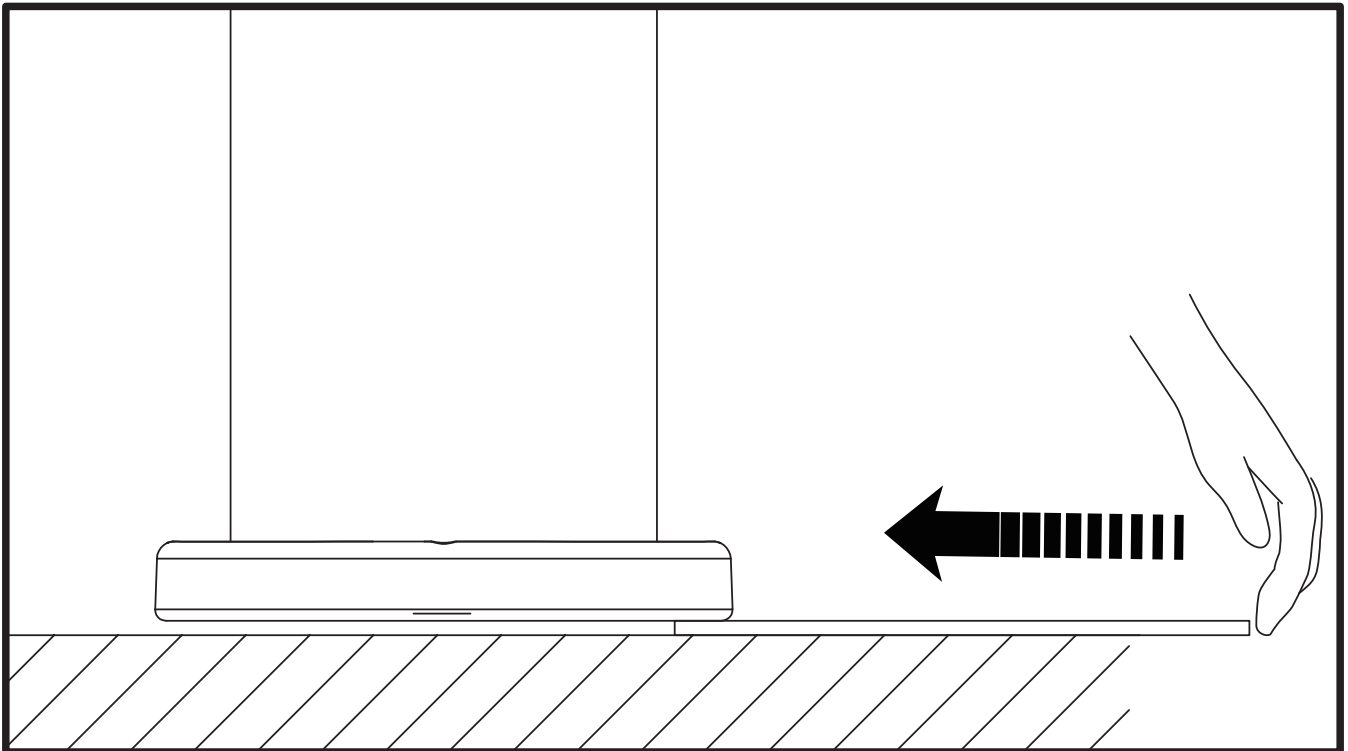

STEP 14 Cable Adjustment

* Insert the stack fork into the gap under the lowest weight plate, and then adjust the large nut at area C. Adjust until the upper stack carriage set moves slightly. To adjust the cable, first insert the (Z) rod and loosen the (Y) nut, and then adjust the (X) nut. If the cable is too long, adjust the (X) nut downward. If too short, adjust the (X) nut upward. After adjusting the (X) nut, tighten the (Y) nut against the weight stack to secure this position.

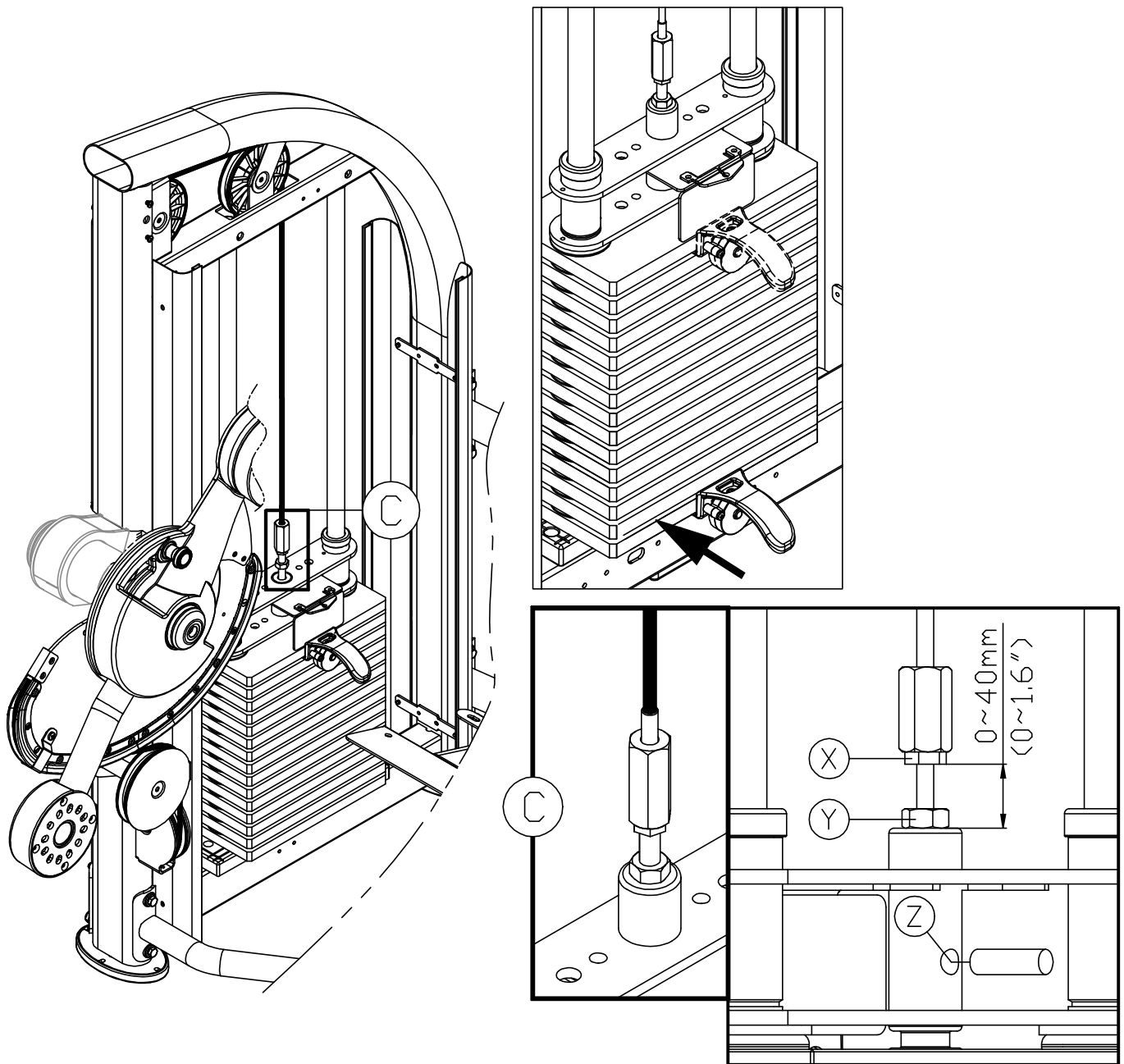

STEP 15 Stack Fork Inspections

- * Please follow operating instructions on the product sticker to test operation and confirm that the equipment is working properly.
- * Insert the stack fork to make sure that every weight plate can be engaged easily.
- * Insert the stack fork at the heaviest weight setting at which you can safely operate the equipment.
- * Exercise to lift the stack several times, and then inspect the cable for proper tightness. If necessary, make adjustments according to the instructions "Cable adjustment" of this manual.
- * Ensure that anyone who is not operator does not near the equipment when testing.

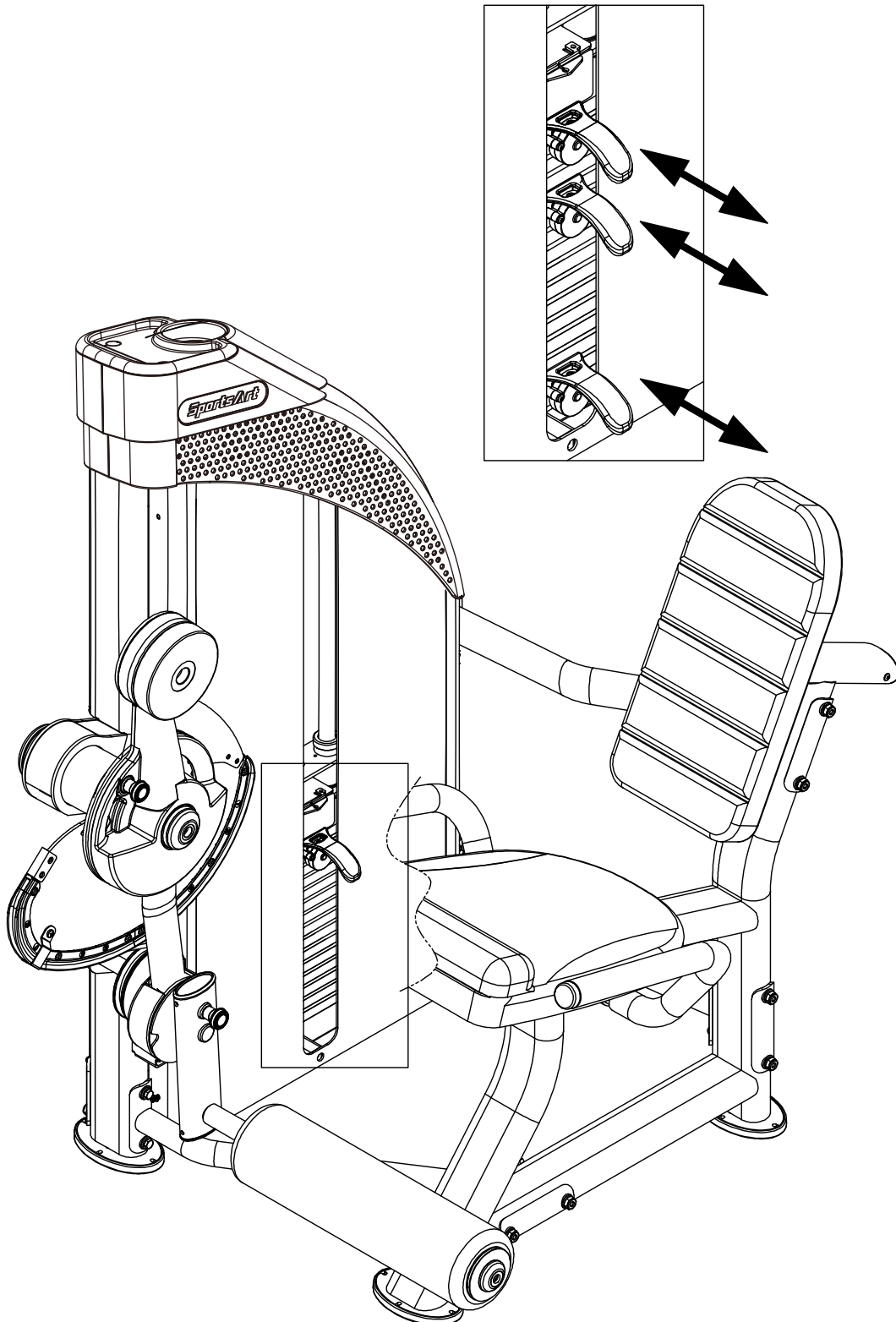

STEP 16 Unit Inspection

After completing the assembly or regular maintenance, please follow instructions (a) through (c) below to inspect the unit. If the unit is disassembled or has been damaged in any way, it might cause injuries or cause the unit to fail.

- (a) Make sure the unit is steady and on a level surface. If the unit is not steady, make adjustments according to the instructions “Level the Unit” of this manual.
- (b) Make sure all parts are assembled and all fasteners are tightened.
- (c) Please follow operating instructions to test operation and confirm that the equipment is working properly. (Please refer to “Operate the Product” of this manual.)

5. OPERATION THE PRODUCT

OPERATION | Safety Operating Area

- (a) Make sure operate the unit in safety area as shown. Do not allow people to be near this area when operating.
- (b) Noise emission under load is higher than without load.
- (c) Over exercising or improper workout position may result in serious injury.
- (d) This product is intended for exercise abdomen.

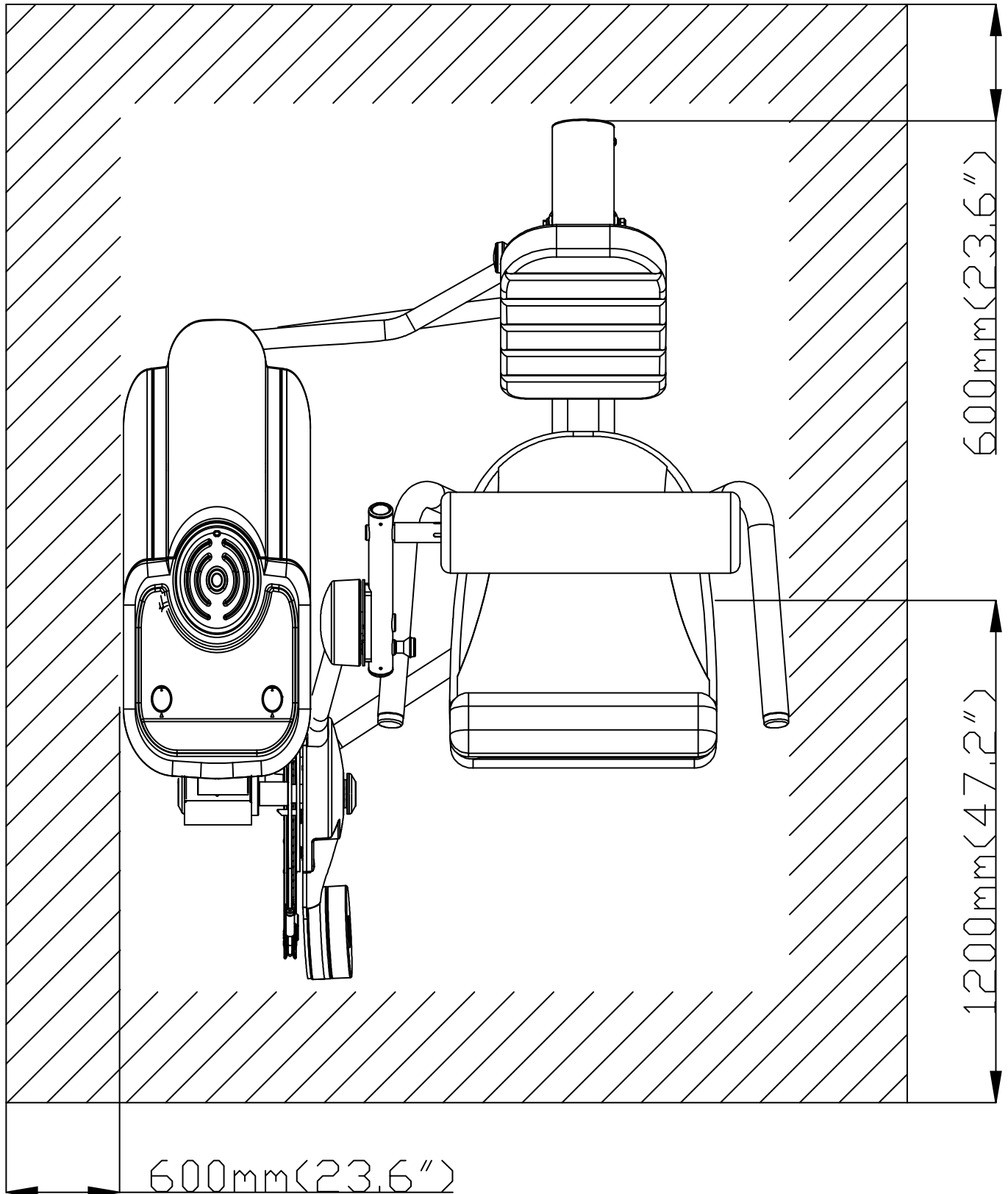

OPERATION | Exercising Instructions

- (a) Select the appropriate weight plates according to your recommended exercise level.
 - (b) Adjust the cylindrical cushion to the most comfortable position and make sure the knob is engaged to secure the position.
 - (c) Perform the exercise in a controlled manner. Inhale when pushing up against resistance and exhale when returning to original position.
- * Please exercise within the range of your skill and training. DO NOT work to exhaustion.
- * All users operate this machine must be supervised under coaches instructions at all times in order for safety.

Please follow the operating instructions as below to test operation.

- (a) Please follow operating instructions on the product sticker to test operation and make sure the equipment is working properly.
- (b) Insert the stack fork at the heaviest weight setting at which you can safely operate the equipment. Exercise to lift the stack several times. Then inspect the cable for proper tightness. If necessary, make adjustments according to the instructions in this manual.

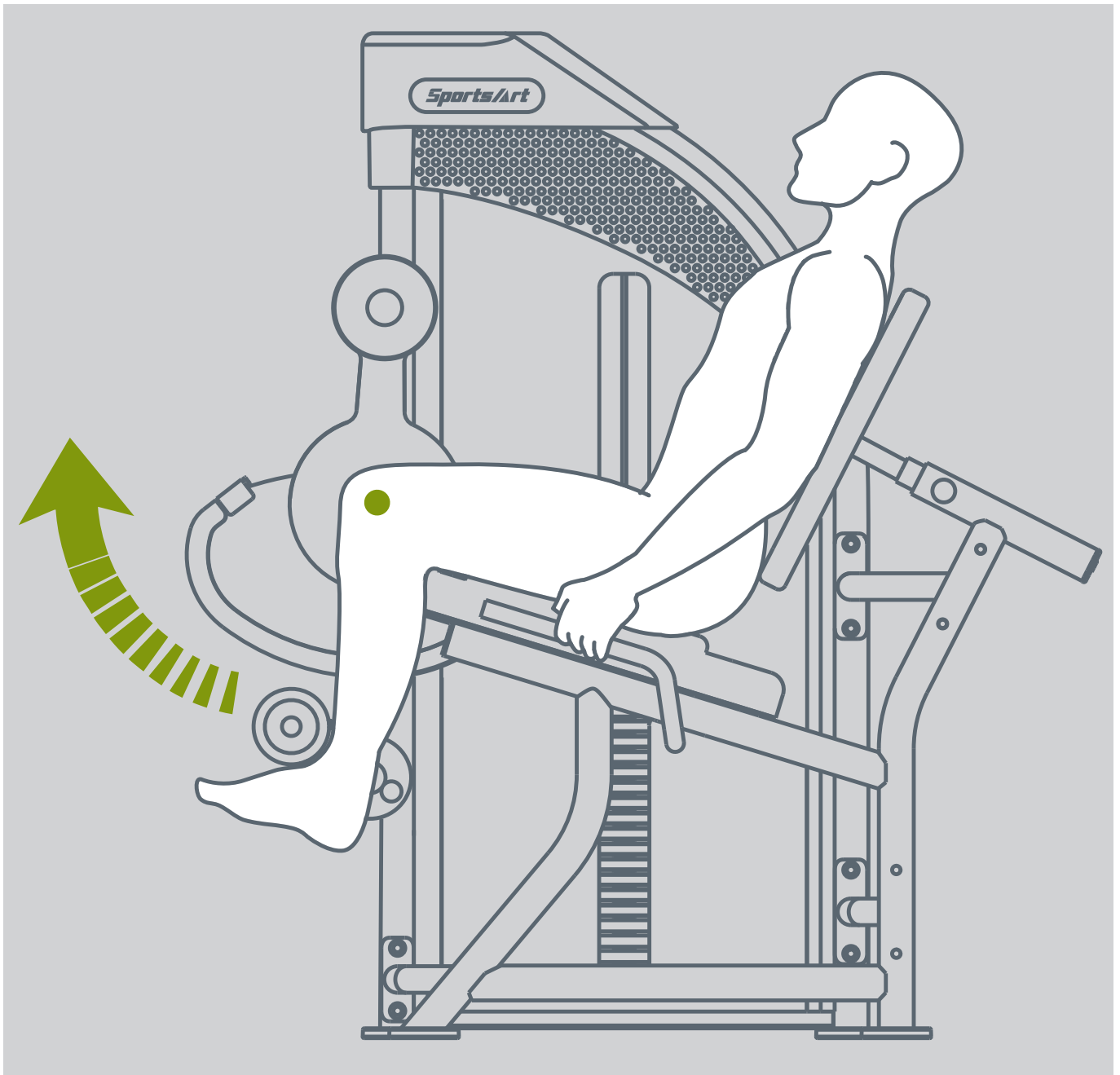

OPERATION Exercising Instructions (CONT.)

- * Pull out the knob to adjust the cylindrical cushion arm position. You can rotate and secure the cylindrical cushion arm as desired for use within a 360 degree range. When released, the knob automatically engages to secure the position.

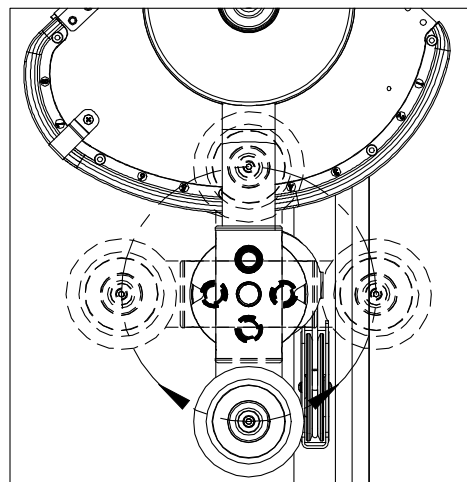
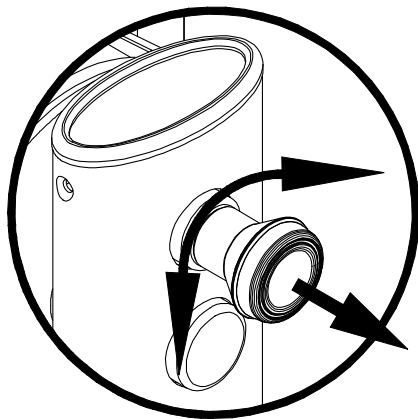
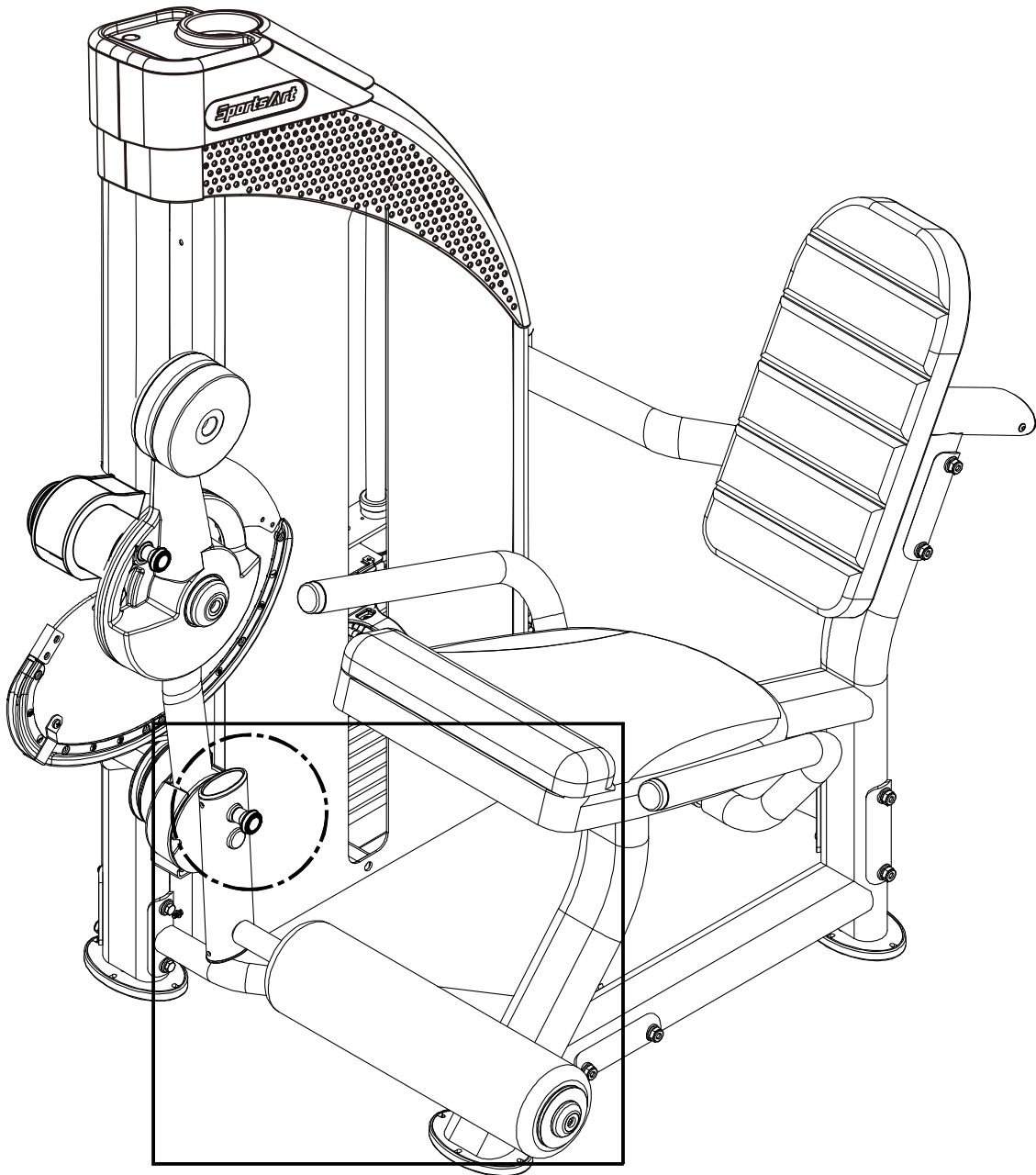

OPERATION Exercising Instructions (CONT.)

*Pull out the knob on the rotator arm of CAM. Place the rotator as desired for use. When released, the knob automatically engages to secure the position.

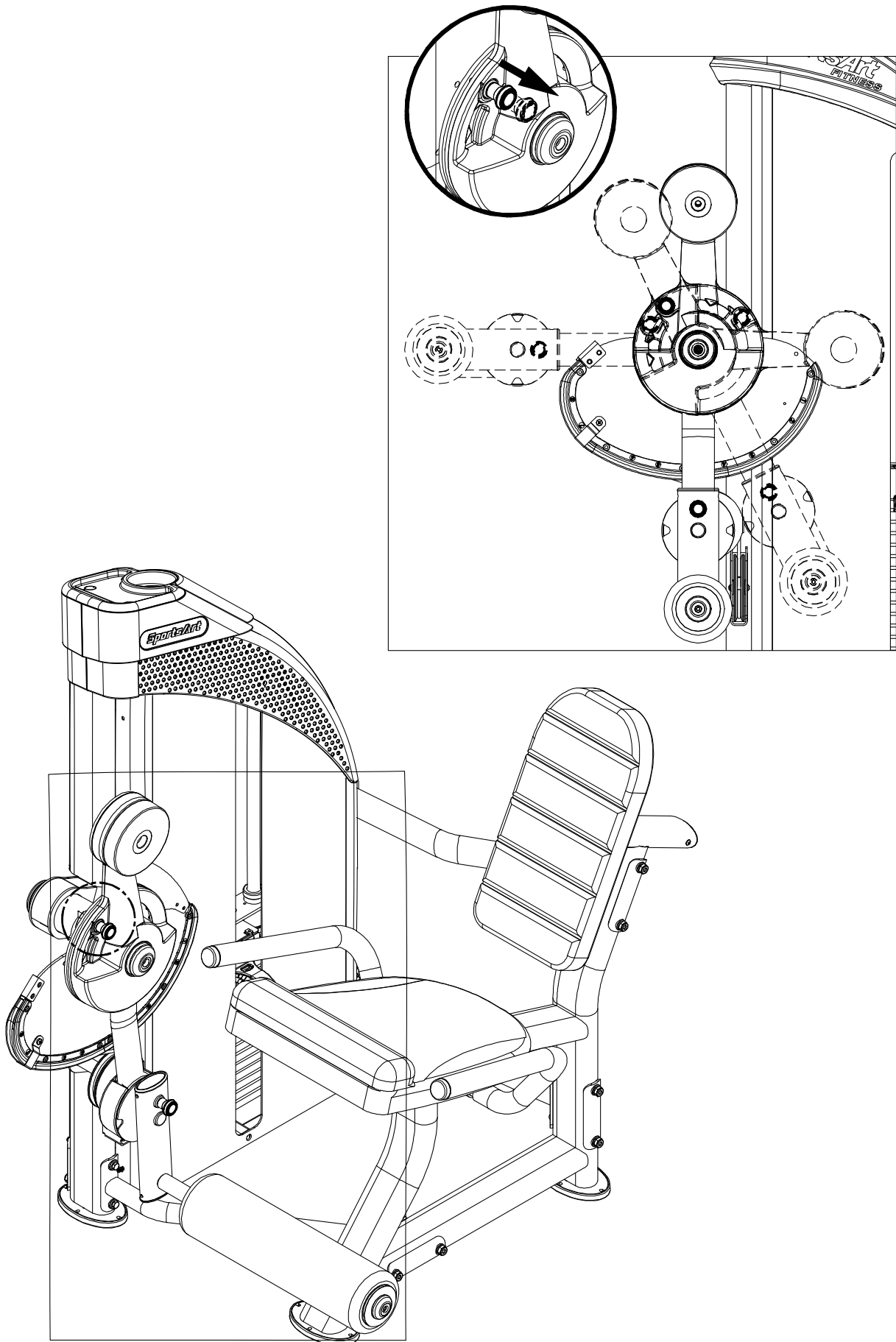

OPERATION Exercising Instructions (CONT.)

* To move the seat back position toward yourself, simply pull it. To move the seat back away from yourself, pull the knob and press the seat back.

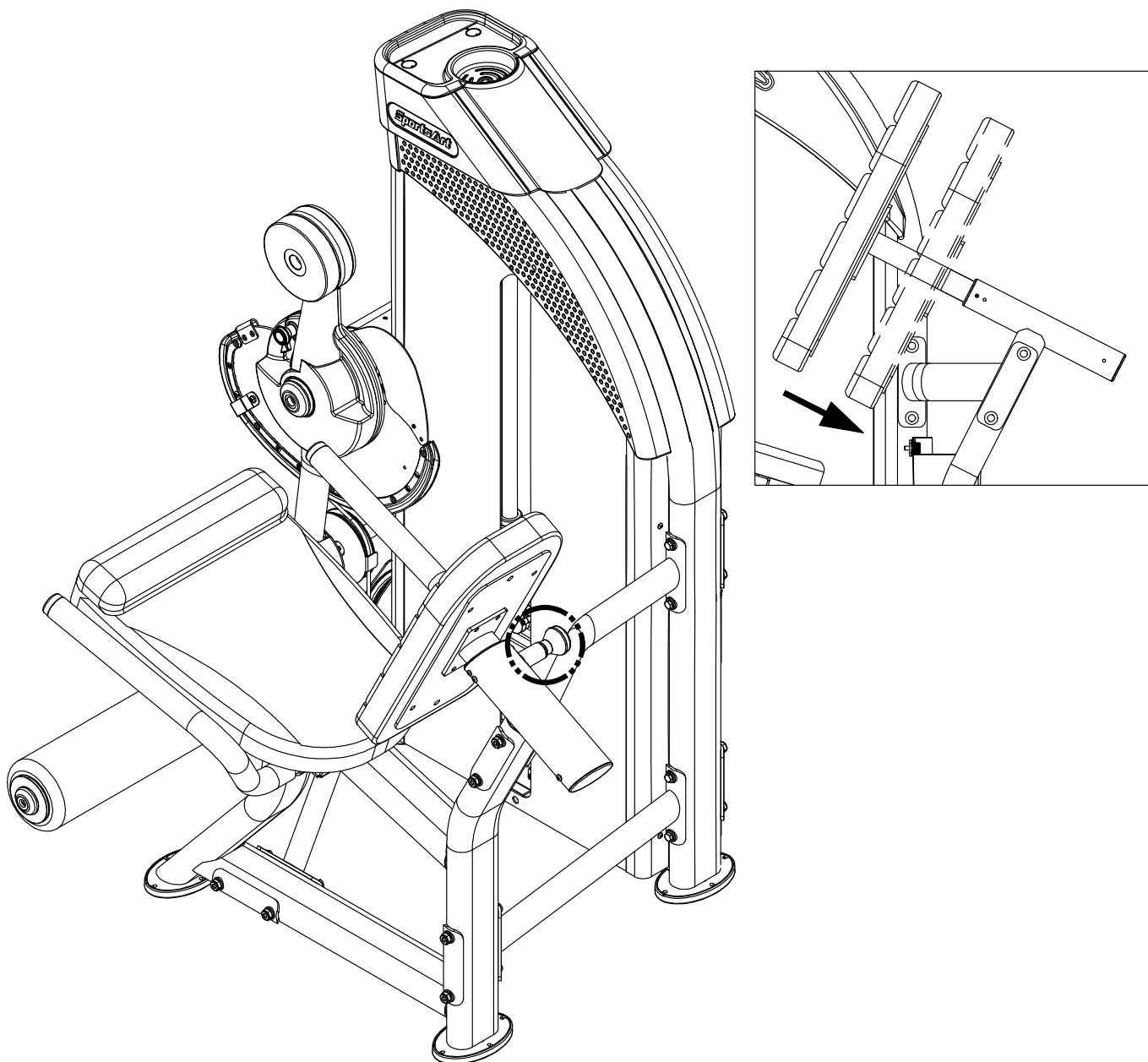

6. MAINTENANCE

This section covers maintenance topics and includes a maintenance schedule, task list, and log.

MAINTENANCE Safety Precautions

- Please follow standard safety precautions when servicing this product.
- Do NOT use a water damp towel to clean the product and do perform the following maintenances.
- Do NOT use cleaners with alcohol, ammonia, or other damaging chemicals. The use of such chemicals can damage the product and void the warranty. Never spray or pour any liquid directly onto the product. Doing so can damage components and void the warranty.
- Use a clean, lint-free towel, dampened with a mixture of Simple Green® all-purpose cleaner, to thoroughly clean the handlebar and the console.
- This product has moving parts that can be hazardous. Exercise caution when maintaining, operating, or moving this product.
- Do not use accessories or parts that are not specifically recommended by the manufacturer (SportsArt) . Such parts might cause injuries or cause the unit to fail and void the warranty. We are not responsible for any safety issue that arises due to the misuse of accessories or parts. At the same time, we will terminate the warranty terms of this equipment.
- Maintenance and repair must be performed by trained service personnel only. Improper maintenance would not only damage the machine, but may also present a danger to the exerciser.
- Keep this product out of use until maintenance is completed.

MAINTENANCE Guide Rod Cleaning and Lubricating

1. Apply lubricant to the guide rods every week.

Procedure:

(a) Put some lubricant on a clean, lint-free cloth. Rub the lubricated cloth on the guide rods.

(b) Load the upper stack carriage set. Exercise to test operation.

(c) Repeat steps (a) and (b) 2-3 times. (Note: the cloth should be lint-free.)

2. After lubricating the guide rods, inspect cable tightness. Refer to the manual, and adjust it if necessary.

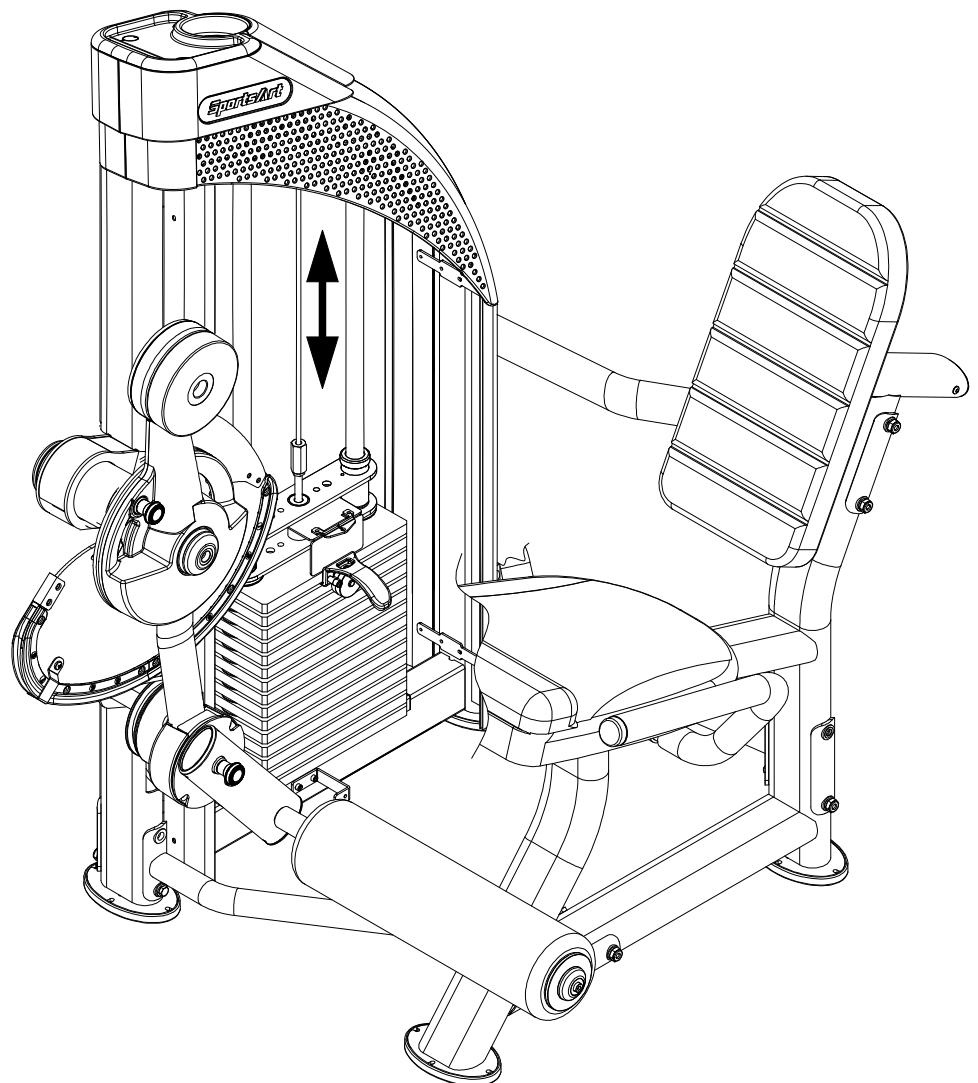
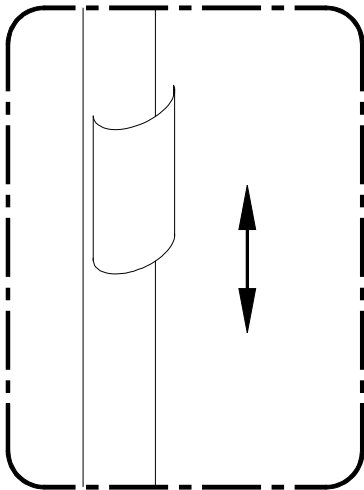
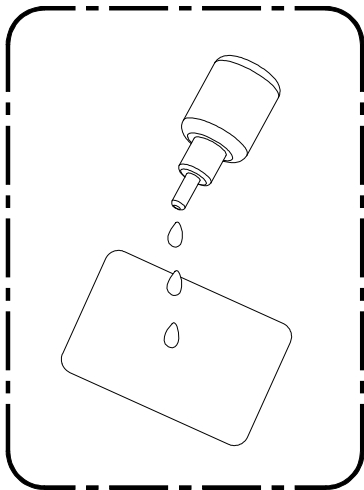

MAINTENANCE Schedule

If there is a need for maintenance of components, please visit the SportsArt website.

cleaning requirements

1.directive 93/42/CEE

2.directive biocide 98/8/CEE

The disinfectant has to be in compliance with Medical Device Directive 93/42/EEC (MDD) and Biocidal Products Directive 98/8/EC (BPD).

It is suited for sensitive synthetic surfaces such as synthetic leather, polycarbonate (PC), acrylic glass and polysulfone, and for the keyboards and control panels.

	Area	Day	Week	Month	Quarter	Year	Notes
1	Exterior	●					Clean.
2	Screws	●					Inspect for looseness and secure if necessary.
3	Test	●					Check for proper equipment operation.
4	Back/Seat Cushion	●					Use dampened cloth to clean.
5	Cable		●				Check for damage or wear. Replace it if necessary.
6	Guide Rod		●				Clean and lubricate.

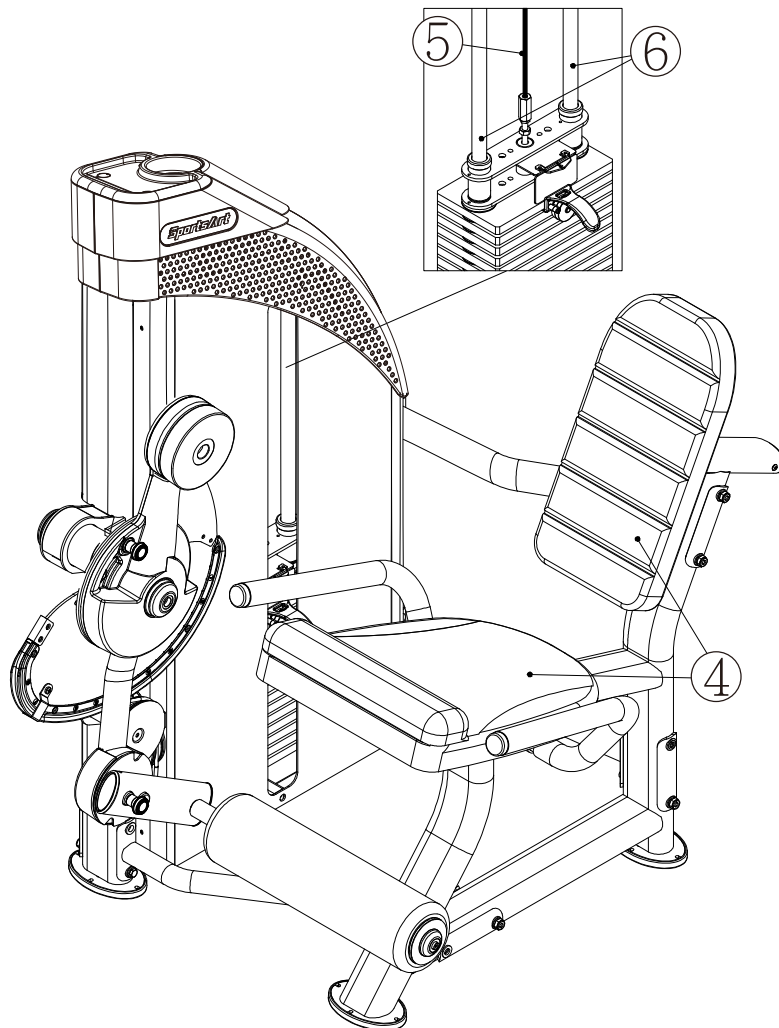

MAINTENANCE Task List

Like cars, fitness products require maintenance. Regular maintenance extends product life, and failure to maintain products can void the manufacturer's warranty. Copy the maintenance log sheet, and record maintenance work for each fitness product.

Daily tasks

1. Use a clean, lint-free towel to wipe down the product exterior.
2. Inspect all screws. Secure if necessary.
3. Make sure the machine is working properly.
4. Wipe the cushions clean with a damp cloth.

Weekly tasks

1. Check the cable for damage or tear.
2. Clean and lubricate the guide rods.

Caution

- Please follow standard safety precautions when servicing this product.
- Do NOT use cleaners with alcohol, ammonia, or other damaging chemicals. The use of such chemicals can damage the product and void the warranty. Never spray or pour any liquid directly onto the product. Doing so can damage components and void the warranty.

MAINTENANCE One-Year Maintenance Log

Facility: _____ Supervisor: _____

Product model number: _____ Serial number: _____

Start date: _____ End date: _____

Daily Tasks	Weeks 1-7	Weeks 8-14	Weeks 15-21	Week 22-28
Completed	<input type="checkbox"/>	<input type="checkbox"/>	<input type="checkbox"/>	<input type="checkbox"/>

Daily Tasks	Week 29-35	Week 36-42	Week 43-49	Week 50-52
Completed	<input type="checkbox"/>	<input type="checkbox"/>	<input type="checkbox"/>	<input type="checkbox"/>

Weekly Tasks	Weeks 1-7	Weeks 8-14	Weeks 15-21	Weeks 22-28
Completed	<input type="checkbox"/>	<input type="checkbox"/>	<input type="checkbox"/>	<input type="checkbox"/>

Weekly Tasks	Weeks 29-35	Weeks 35-42	Weeks 43-49	Weeks 50-52
Completed	<input type="checkbox"/>	<input type="checkbox"/>	<input type="checkbox"/>	<input type="checkbox"/>

Monthly tasks	1	2	3	4	5	6	7	8	9	10	11	12
Completed	<input type="checkbox"/>	<input type="checkbox"/>	<input type="checkbox"/>	<input type="checkbox"/>	<input type="checkbox"/>	<input type="checkbox"/>	<input type="checkbox"/>	<input type="checkbox"/>	<input type="checkbox"/>	<input type="checkbox"/>	<input type="checkbox"/>	<input type="checkbox"/>

Quarterly Tasks	Quarter 1	Quarter 2	Quarter 3	Quarter 4
Completed	<input type="checkbox"/>	<input type="checkbox"/>	<input type="checkbox"/>	<input type="checkbox"/>

Yearly Tasks	Year 1
Completed	<input type="checkbox"/>

Notes: _____

7. CONSIGNES DE SÉCURITÉ IMPORTANTES

Le produit SportsArt a été conçu et fabriqué afin d'assurer une sécurité optimale. Cependant certaines précautions s'appliquent chaque fois que vous utilisez votre produit.

- Lisez entièrement le manuel avant l'assemblage et l'utilisation. Veuillez aussi noter les consignes de sécurité suivantes:
- Veuillez lire attentivement les instructions et installer le produit selon les instructions.
- Assemblez et faites fonctionner le produit sur une surface solide et plane; NE PAS l'utiliser à l'extérieur ou près de l'eau.
- En aucun cas, ne laissez des enfants à proximité ou sur le produit.
- Vérifiez le tapis de course avant chaque utilisation. Assurez-vous que toutes les pièces sont assemblées et que tous les éléments de fixation sont serrés. NE PAS utiliser le produit si l'appareil est démonté de quelque façon.
- Gardez vos mains loin des pièces mobiles.
- Portez des vêtements d'entraînement appropriés; NE PORTEZ PAS de vêtements amples. NE PORTEZ PAS de chaussures à semelles en cuir ou à talons hauts. Attachez les cheveux longs.
- Soyez prudent lors du montage et démontage de l'appareil.
- NE PAS utiliser d'accessoire non spécifiquement recommandé par le fabricant. Car cela pourraient provoquer des blessures ou entraîner une panne de l'appareil.
- Débranchez l'appareil de la prise avant l'entretien ou la suppression de toute pièce.
- Une surveillance étroite est nécessaire quand le produit est utilisé par ou à proximité d'enfants, de malades ou de personnes handicapées.
- Utilisez ce produit uniquement pour l'usage prévu dans ce manuel.
- La limite de poids de l'utilisateur pour le produit est de 227 kg, 500 lb.
- Ce produit n'est pas destiné à être utilisé par des personnes (y compris des enfants) dont les capacités physiques, sensorielles ou mentales sont réduites ou qui ne disposent pas de l'expérience ou du savoir nécessaires, sauf si celles-ci ont au préalable été formées eu égard à l'utilisation de produit par une personne responsable de leur sécurité.
- Les enfants doivent être encadrés afin d'empêcher qu'ils ne jouent avec le produit.

ATTENTION

Si vous ressentez une douleur ou si vous avez une sensation anormale, ARRÊTEZ VOTRE ENTRAÎNEMENT et consultez immédiatement votre médecin. Entraînez-vous à votre niveau d'exercice recommandé. NE PAS s'entraîner jusqu'à l'épuisement. Avant de commencer un programme d'exercice, vous devriez consulter votre médecin. Il est recommandé de faire un examen physique complet. Dans ce manuel, les mots "gauche" et "droit" sont utilisés en référence aux pièces et au produit. Comme tels, les mots "gauche" et "droit" font respectivement référence aux côtés gauche et droit de l'exerciseur. De même pour plus de concision, le mot «vis» est utilisé dans certains cas où des rondelles, des vis et autres matériels sont associés.

8. APPENDIXES

APPENDIXES Optional accessories

Top weight(100 kg = (5KG × 1 pcs) + (5KG × 7 pcs) + (7.5KG × 8 pcs))

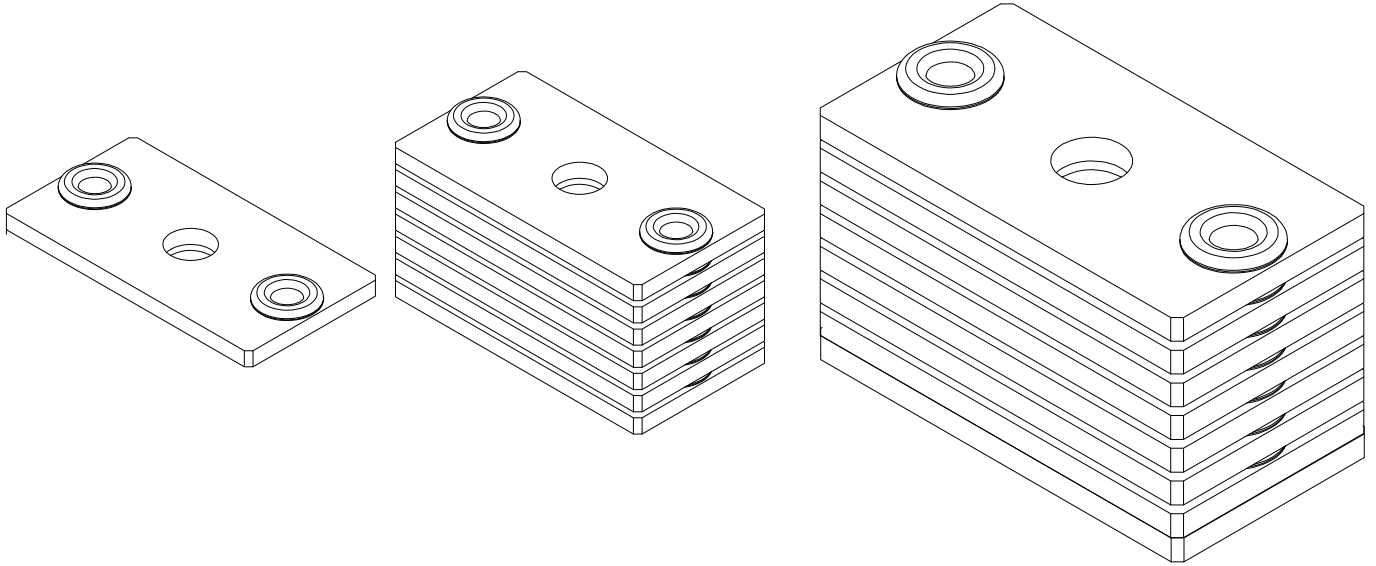

P857 Leg Extension

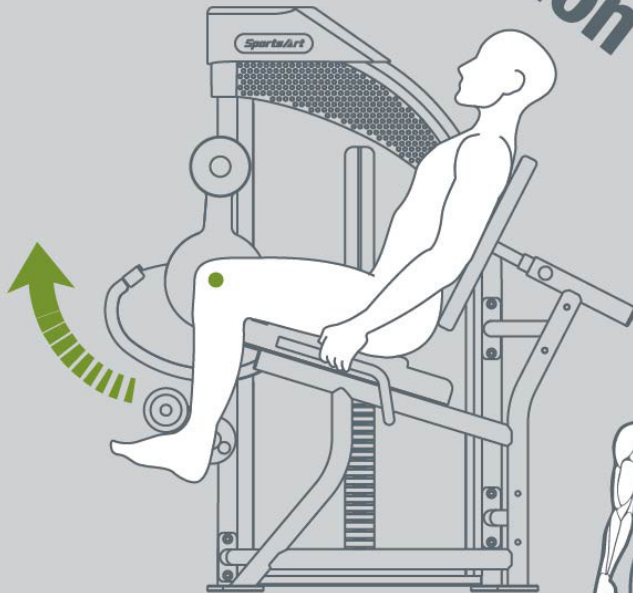

- 1 Select a resistance level that enables you to perform the movement correctly.
- 2 Adjust back support so knees are positioned at pivot point height.
- 3 Position the roller pad above the feet against the shins. Place back against back pad. Maintain fixed position while grasping the handles.
- 4 Extend legs forward and up, keeping torso and hips stationary and in contact with the pads.
- 5 Perform the exercise in a controlled manner. Exhale when pushing against resistance.

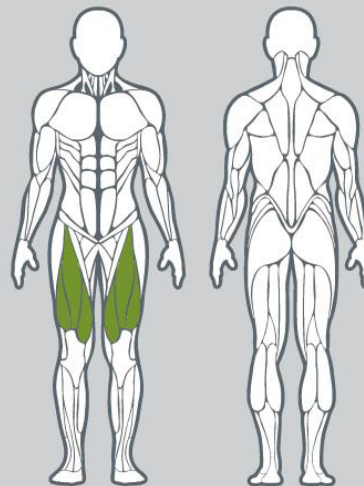

www.sportsartfitness.com

CAUTION

Do not use this machine if you are unfamiliar or do not know how to operate it. Do not allow people near this machine when in use. Keep clear of parts not intended for contact during exercise. For your safety, exhale while you exert force.

Your Authorized Distributor