

# TABLE OF CONTENTS

## CHAPTER 1: SAFETY PRECAUTIONS

1.1 SAFETY PRECAUTIONS.....	1
-----------------------------	---

## CHAPTER 2: INSTRUCTIONS

2.1 DIMENSIONS.....	2
2.2 LIST OF PARTS.....	3
2.3 COMPONENTS in the Hardwars Kit.....	4
2.4 COMPONENTS on the Product.....	4

## CHAPTER 3: ASSMBLY INSTRUCTIONS

3.1 SETP1.....	5
3.2 SETP2.....	6
3.3 SETP3.....	7

## CHAPTER 4: OPERATION INSTRUCTIONS..... 8

4.1 Adjusting the resistance.....	8
4.2 Usage and Maintenance.....	9

# CHAPTER 1 – SAFETY PRECAUTIONS

## 1.1 SAFETY PRECAUTIONS

1. Read and follow all cautionary messages and warnings in this manual. Obtain instructions on the proper use of this machine prior to exercising. Use appropriate body positioning and controlled movements.
2. To address your particular needs and physical condition, consult your physician before beginning any exercise program.
3. Assemble and operate this product on a solid, level surface. Do not use outdoors or near water.
4. Never allow children on or near the equipment.
5. Make sure all fasteners are properly tightened for safety. DO NOT use the product if the unit is disassembled in any way.
6. Keep your head, body, limbs, and fingers clear of all moving parts.
7. If at any time during exercise you feel faint, dizzy, or experience pain, stop exercising and consult your physician.
8. DO NOT wear loose or dangling clothing while using the equipment. Keep away from all moving parts.
9. Use care when mounting and dismounting the unit.
10. DO NOT use any accessories that aren't specifically recommended by the manufacturer. Aftermarket accessories might cause injuries or cause the unit to fall.
11. Close supervision is necessary when this product is used by, on, or near adolescents, invalids and disabled persons.
12. Use this product only for its intended use as described in this manual.
13. Never operate this product if it has been damaged in any way. If it is not working properly or has been dropped or damaged, contact your dealer. DO NOT attempt to fix a broken or jammed machine. Contact a qualified fitness product technician.
14. Never drop or insert any object into any opening.
15. Ensure that an area of 2000 x 1000 mm behind the exercise bike is free of obstacles.

Note that throughout this assembly guide the words “left” and “right” are used in regard to the product and its parts. As such, these side designations correspond to the left and right sides of a person in place to exercise on the product. Also, for brevity, the word “screws” is used at times when screws, washers, and other hardware may be involved.

## CHAPTER 2—INSTRUCTIONS

### 2.1 DIMENSIONS

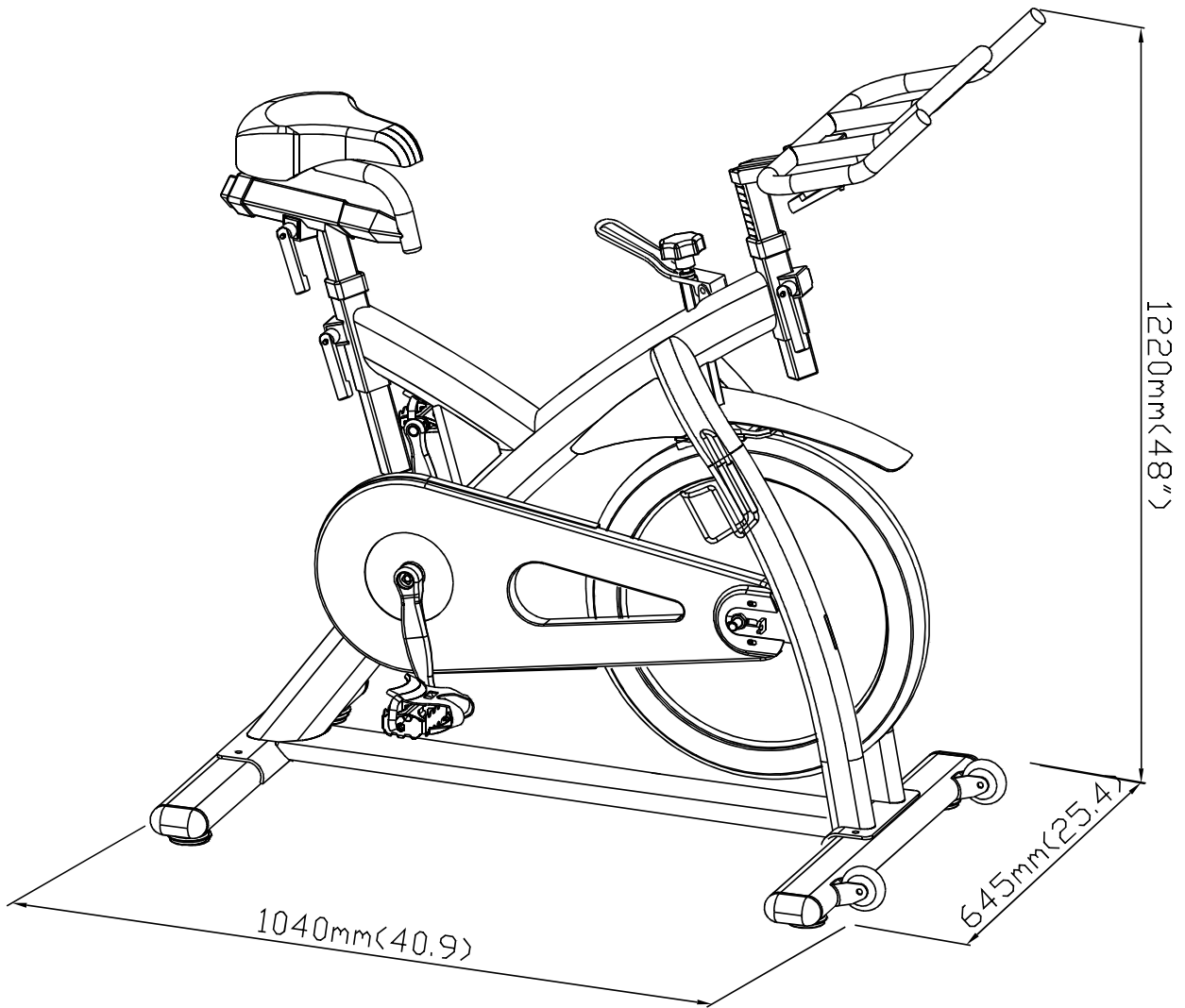

## 2.2 LIST OF PARTS

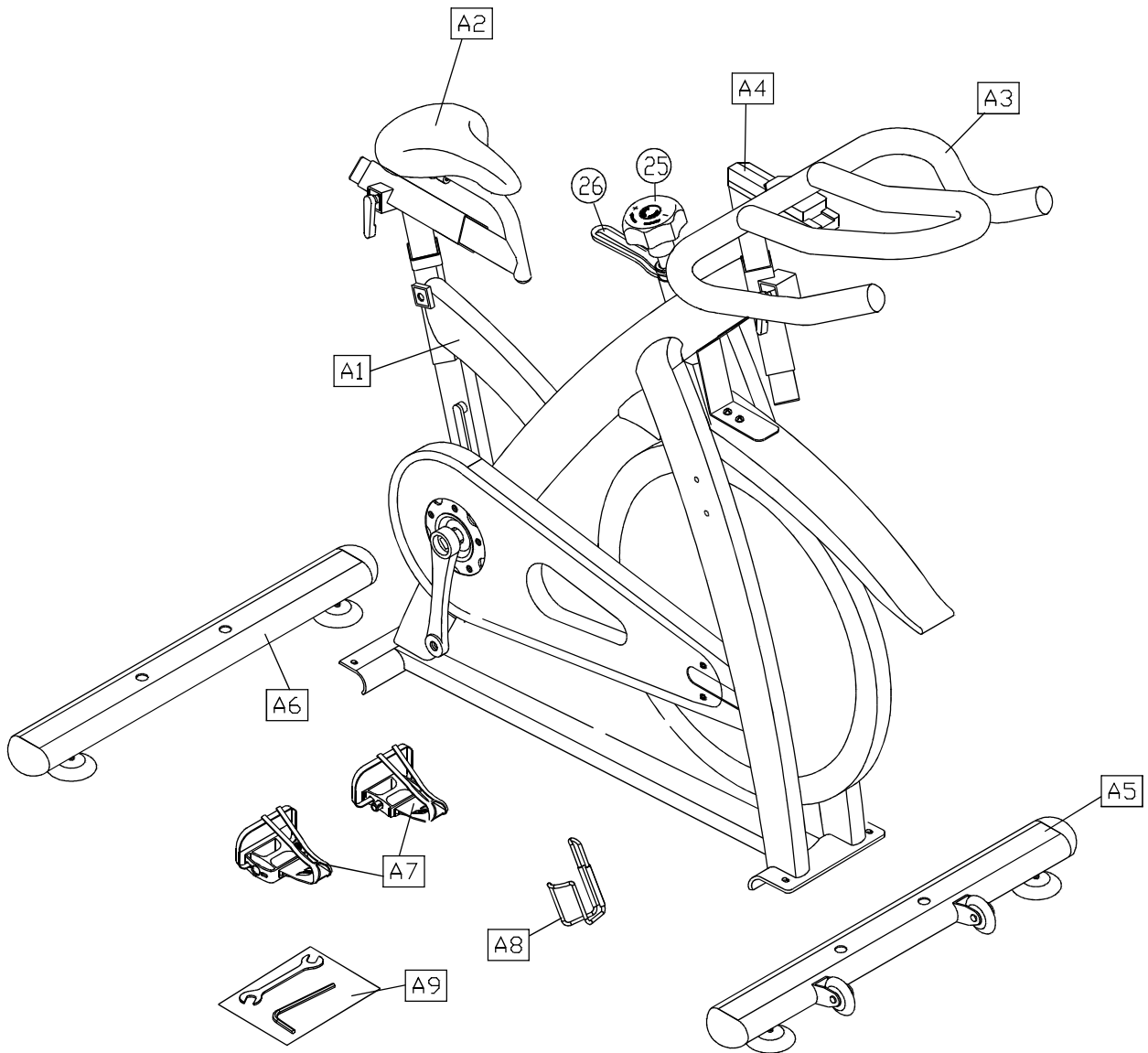

Assembly Parts					
Number	Name	Qty	Number	Name	Qty
A1	Main frame	1	A7	Pedal	1
A2	Saddle	1	A8	Bottle cage	1
A3	Handle bar w/stainless slider	1	A9	Hardware kit	1
A4	Stainle Handle bar post	1			
A5	Front stabilizer tube	1			
A6	Rear stabilizer tube	1			

## 2.3 COMPONENTS in the Hardwars Kit

Hardware Kit				
Number	Name	Qty	Specification	Notes
	L-shaped Allen wrench	1	(M4)	
	Open-end wrench	1		

## 2.4 COMPONENTS on the Product

Components on the Product			
Number	Name	Specification	Notes
41	Stainless nut for stabilizer tube		
	Stainless washer for stabilizer tube		
	Fixing bolt for stabilizer tube		
22	Handle bar release lever		
23	Stainless screw for bottle cage		
24	Stainless screw for bottle cage		
	Stainless washer for bottle cage		
25	Brake system		
26	Brake handle		

## CHAPTER 3—ASSMBLY INSTRUCTIONS

### 3.1 STEP 1

- (a) Remove screws (21) from the front and rear stabilizer tubes (A5, A6).
- (b) Use screws (21) to secure front and rear stabilizer tubes (A5, A6) onto the main frame (A1).

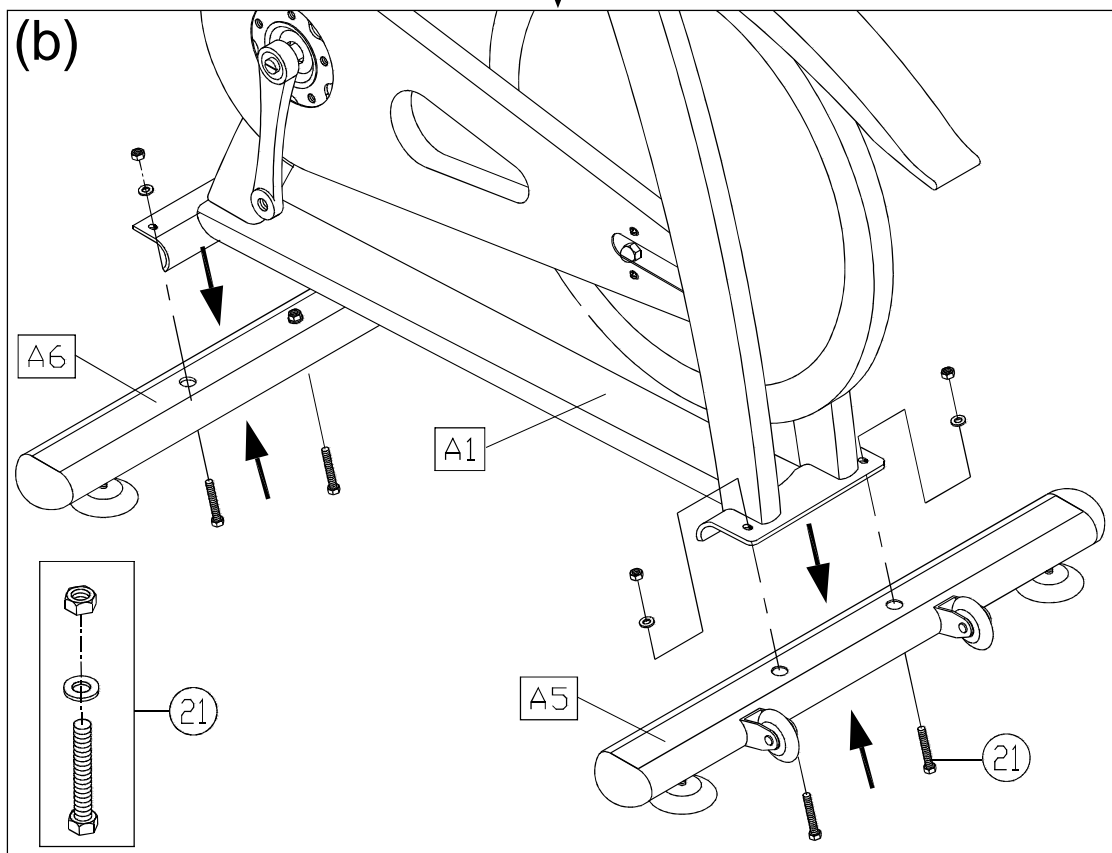
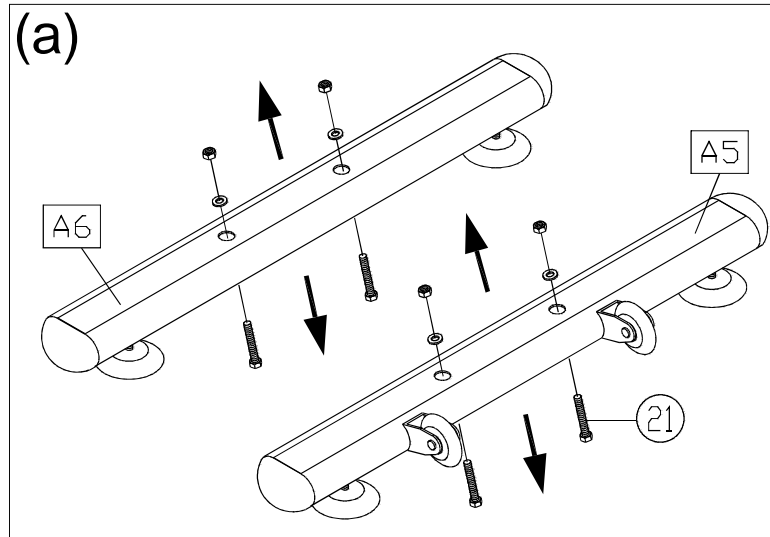

### 3.2 STEP 2

- (a) Remove the handlebar release lever (22) from the handlebar w/stainless slider (A3) in order @b.
- (b) Rotate to release the set knob. Remove the filler tube, and insert the stainless handlebar post (A4) into the main frame (A1). Then rotate to secure the set knob.
- (c) Assemble the handlebar w/stainless slider (A3) onto the stainless handlebar post (A4) in order @b. Then secure the handlebar release lever (22).

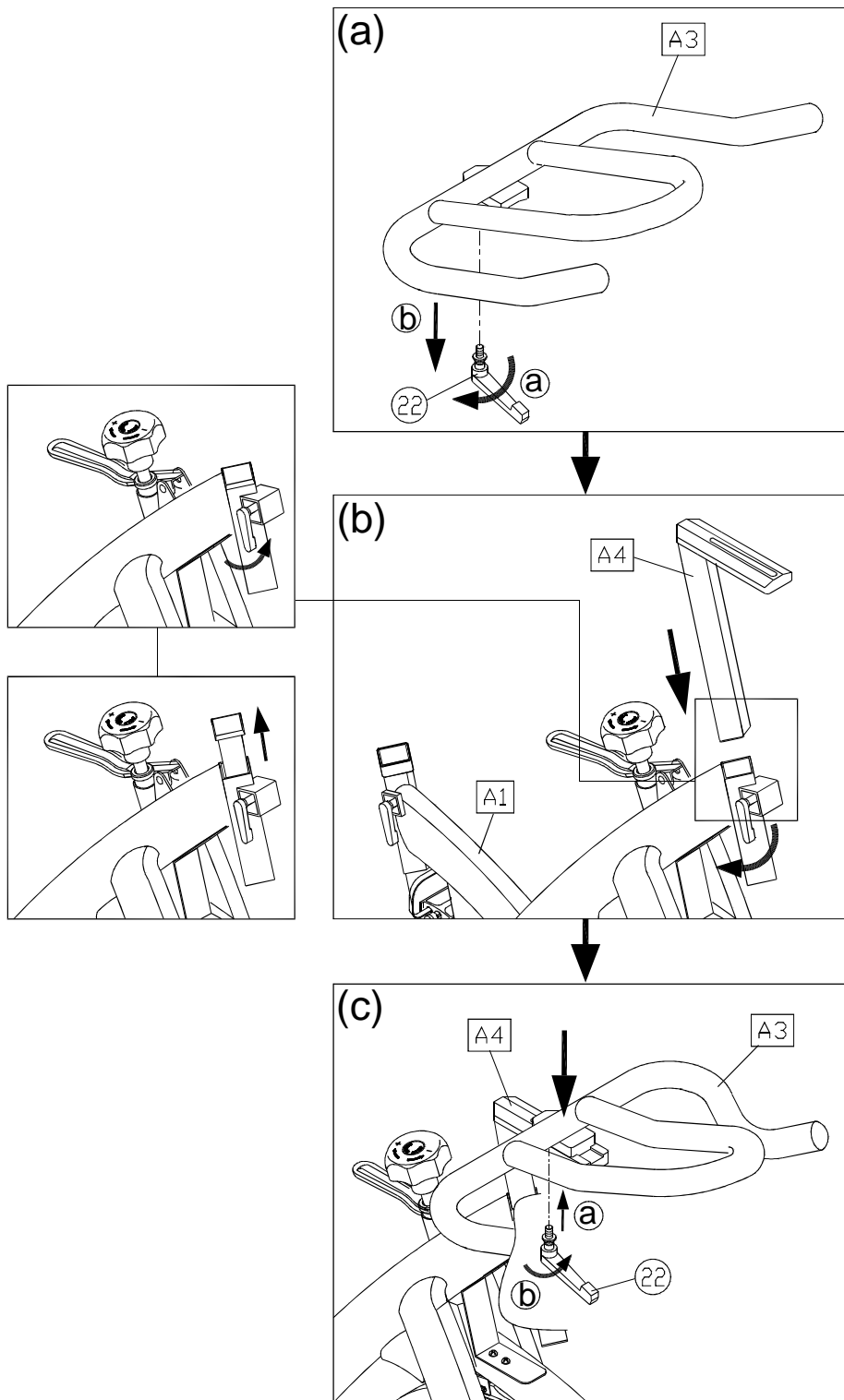

### 3.3 STEP 3

- (a) Install the saddle (A2) onto the main frame (A1). Then secure the saddle (A2) nuts on both sides.
- (b) Secure pedals (A7) onto the cranks.
- (c) Remove screws (23)(24) from the main frame (A1). Then secure the bottle cage (A8) into place.

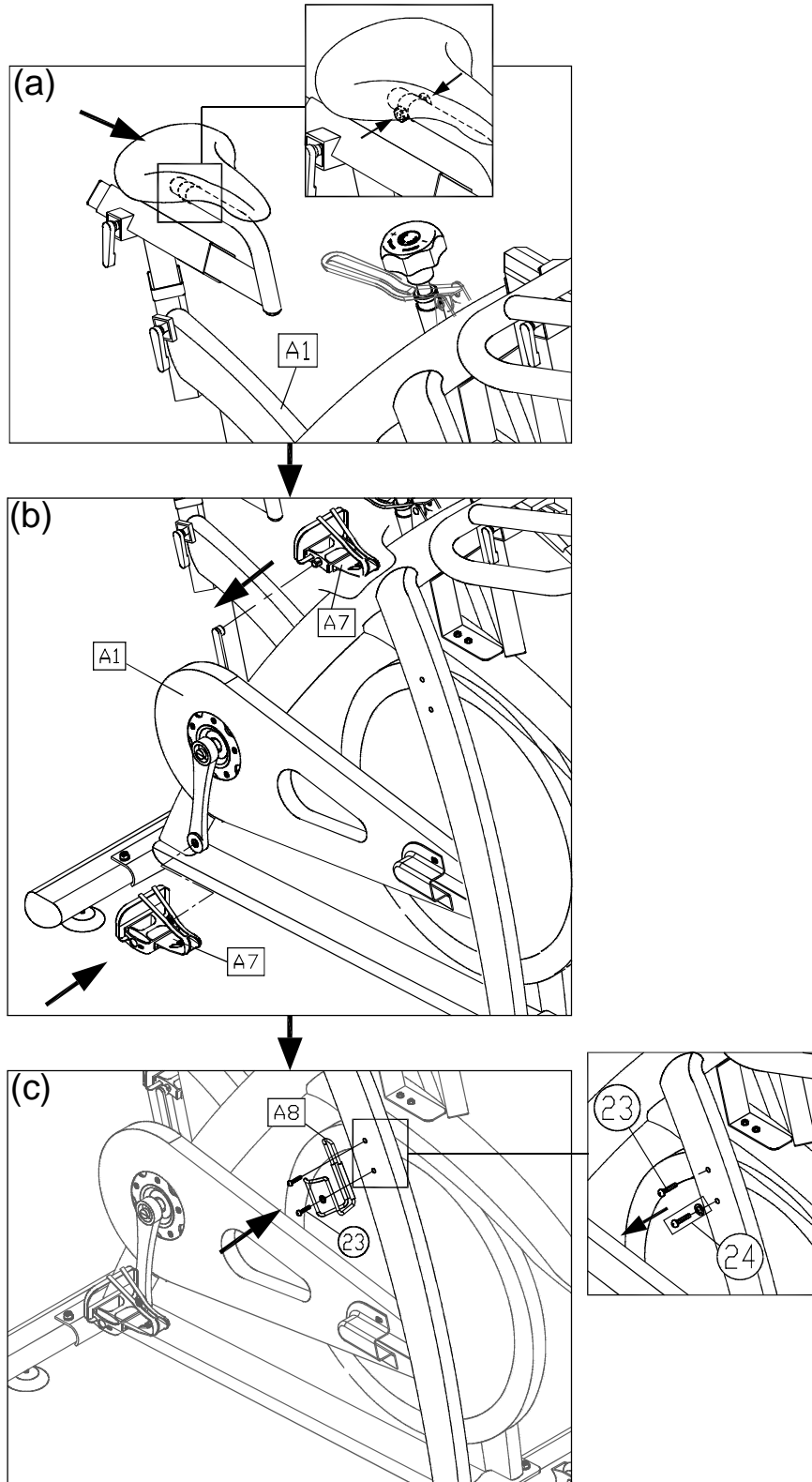



## CHAPTER 4— OPERATION INSTRUCTIONS

### 4.1 Adjusting the resistance

Use the brake knob (25) to loosen (-) or tighten (+) resistance as you exercise.

The flywheel should rotate freely without any resistance when you loosen (-) the brake system fully.

More experienced riders may wish to increase the overall resistance by tightening (+) the brake system.

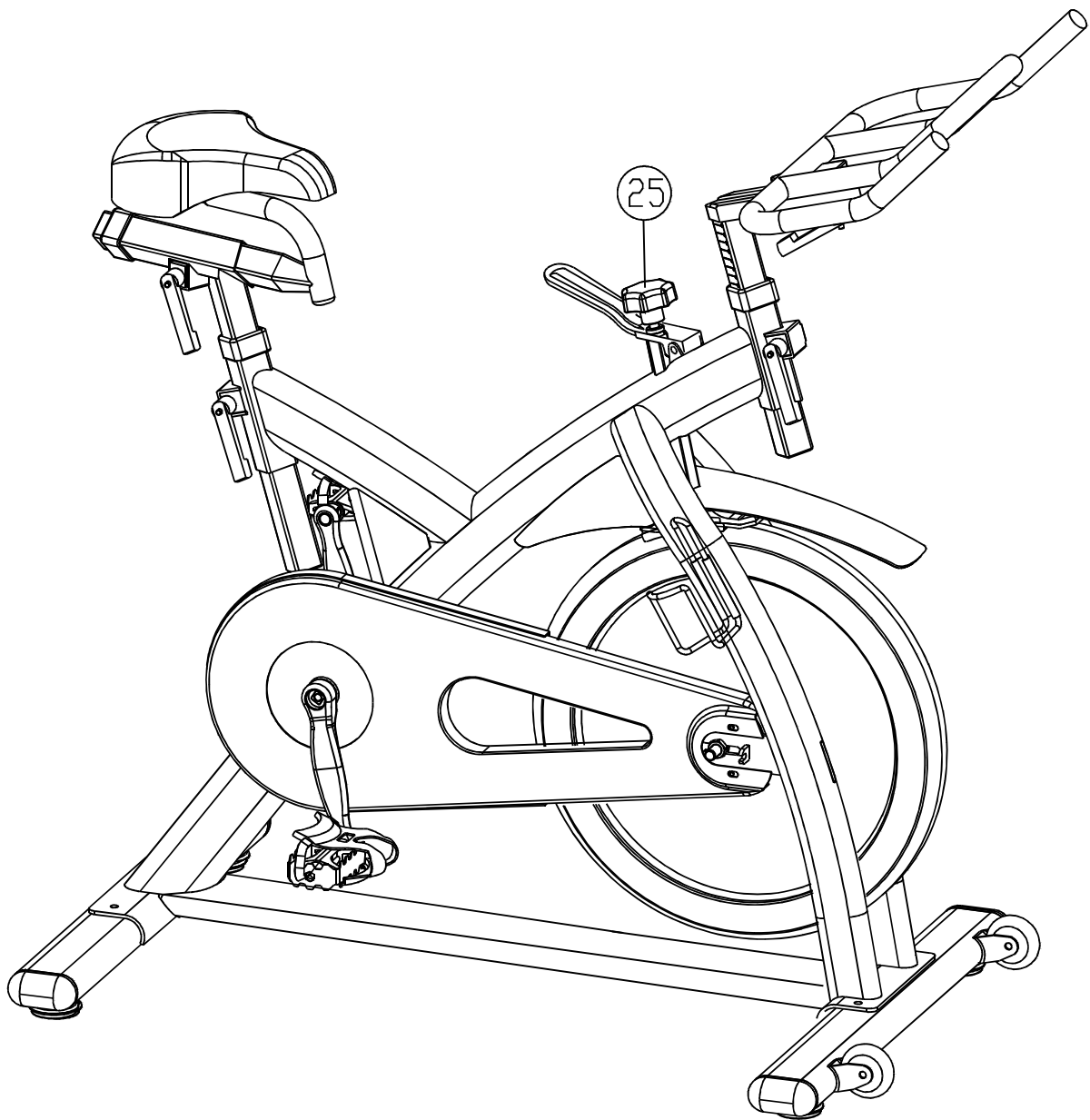

## 4.2 Usage and Maintenance

- (1) Model C510 is designed to be used as an indoor cycle in fitness studios and health clubs. It has a fixed, wheel-driven flywheel, and should only be used under professional supervision.
- (2) It is important that the C510 is correctly assembled. We recommend that a qualified installer assemble the bike.
- (3) Handlebar and seat adjustment. It is important that the handlebar and seat are set at the correct height for your body. If necessary, ask your instructor for assistance. To adjust the handlebar height, undo the release lever where the handlebar post fits into the frame. Slide the handlebar post up or down to the required height and retighten the release lever. Make sure the handlebar is secure, with no lateral or vertical movement. The handlebar position can be adjusted forward or backward. Undo the release lever located below the handlebar slider. Slide the handlebar assembly forward or backward until you reach the required position. Then securely tighten the release lever.
- (4) Seat height adjustment. Undo the release lever located where the seat post fits into the frame. Adjust the seat to the required height. Then retighten the release lever. Make sure the lever is tight enough to prevent the seat from twisting side to side. The seat position can be adjusted forward and backward. Undo the release lever located beside the seat slider. Loosen the release lever, slide the seat to the required position, then retighten the release lever.
- (5) Pedal and toe straps. Your feet should be securely positioned in the toe clips during exercise. Put your foot as far forwards as possible into the toe-clip, and pull the strap tight.
- (6) The C510 should operate on a level surface with no lateral movement. There is a height adjustment pad underneath both sides of the foot tube. Rotate these pads upward or downward until the bike is totally stable on the ground.
- (7) To stop the wheel quickly, engage the emergency brake(25)(26) by pressing its handle down.

Maintenance – This product may become unsafe when bolts or other parts become loose, or when there is excessive noise from the flywheel. Like any other mechanical device, the C510 should be maintained regularly. Ask your supplier about a regular maintenance program. Refer to the following maintenance chart.

No	DESCRIPTION	Daily	Weekly	Monthly	Quarterly	Annually
1	Wipe machine down	X				
2	Spray the frame with WD40	X				
3	Perform a visual check	X				
4	Check security of handle bar post & seat post	X				
5	Check security of saddle	X				
6	Remove handlebar post and clean tube		X			
7	Remove seat and clean tube		X			
8	Check brake pads for wear and proper alignment		X			
9	Check brake adjustment		X			
10	Check security of all knobs & the release lever		X			
11	Check toe straps for signs of wear		X			
12	Check crank bolts and re-tighten		X			
13	Make sure pedals are screwed in		X			
15	Wipe a rust inhibitor on the flywheel, handlebar, and seat tube set		X			
14	Check belt tension			X		
16	Check the bottom bracket				X	
17	Check flywheel bearings				X	
18	Perform a full frame inspection					X



**SPORTS ART INDUSTRIAL CO., LTD.  
(Headquarters)**

No. 11, Gong Huan Road, Tainan City,  
70955 Taiwan  
TEL: +886 6 3840 888  
FAX: +886 6 3840 999  
E-mail: [info@sportsart.com.tw](mailto:info@sportsart.com.tw)

**GERMANY**

Medex Fitnessgeräte GmbH  
Mörnerstr. 15  
09629 Reinsberg OT Neukirchen  
Deutschland  
TEL: +49 37324 829 839  
FAX: +49 37324 829 840  
E-mail: [info@medex-gmbh.com](mailto:info@medex-gmbh.com)

**NORTH & LATIN AMERICA**

8217 44th Ave W. Suite A,  
Mukilteo WA 98275,  
USA  
TEL: +1 425 4819479  
FAX: +1 425 4888155  
E-mail: [info@aosportsart.com](mailto:info@aosportsart.com)

**CHINA**

No.8 Chuangye East First Road,  
Shuanglin Area, Liangang Industrial Zone,  
Jinwan District, Zhuhai, Guangdong, China  
TEL: +86 756 3982888  
FAX: + 86 756 3982996  
E-mail: [info@sportsart.com.cn](mailto:info@sportsart.com.cn)